



MULTI-INNO TECHNOLOGY CO., LTD.

www.multi-inno.com

OLED MODULE SPECIFICATION

Model : MI9696CO

For Customer's Acceptance:

Customer	
Approved	
Comment	

Revision	1.1
Engineering	
Date	2012-12-19
Our Reference	

CONTENT

- PHYSICAL DATA
- EXTERNAL DIMENSIONS
- ABSOLUTE MAXIMUM RATINGS
- ELECTRICAL CHARACTERISTICS
- TIMING OF POWER SUPPLY
- ELECTRO-OPTICAL CHARACTERISTICS
- INTERFACE PIN CONNECTIONS
- RELIABILITY TESTS
- OUTGOING QUALITY CONTROL SPECIFICATION
- CAUTIONS IN USING OLED MODULE

■ PHYSICAL DATA

No.	Items	Specification	Unit
1	Display Mode	Passive Matrix OLED	-
2	Display Color	65,536 Colors (Maximum)	-
3	Duty	1/96	-
4	Resolution	96 (H) x 96 (V)	Pixel
5	Active Area	19.852 (W) x 19.852 (H)	mm
6	Outline Dimension	25.90 (W) x 30.10 (H) x 1.30 (D)	mm
7	Pixel Pitch	0.207 (W) x 0.207 (H)	mm
8	Pixel Size	0.187 (W) x 0.187 (H)	mm
9	Driver IC	SEPS114A	-
10	Interface	8-bit parallel,4-wire SPI	-
11	Weight	2.07	g

EXTERNAL DIMENSIONS

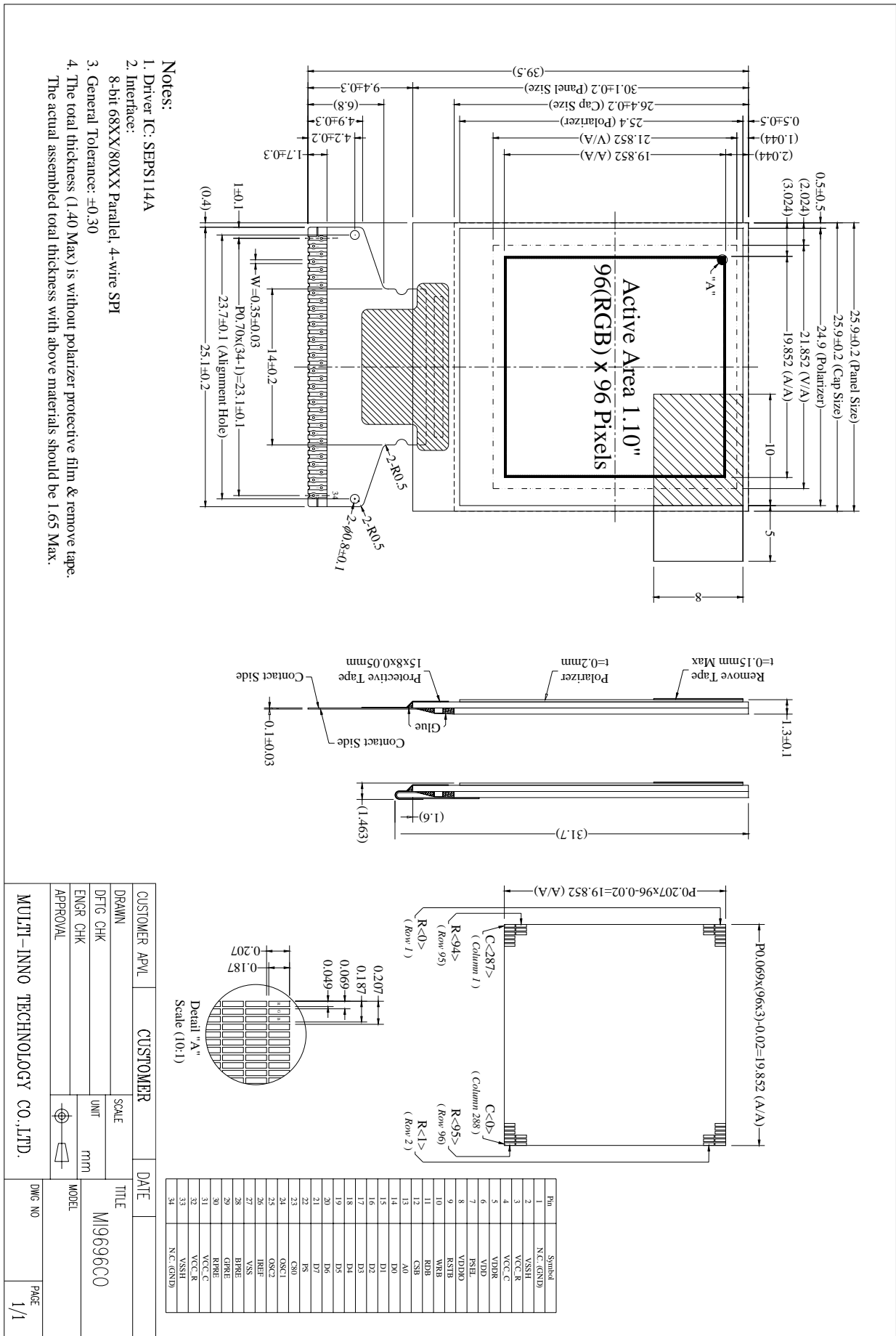

■ ABSOLUTE MAXIMUM RATINGS

Items	Symbol	Min	Typ.	Max	Unit	Notes
Supply voltage for operation	VDD	-0.3	-	4	V	1,2
Supply voltage for I/O pins	VDDIO	-0.3	-	4	V	1,2
Supply voltage for display	VCC_C	-0.3	-	15	V	1,2
Operating temperature	T _{OP}	-40	-	70	°C	3
Storage temperature	T _{ST}	-40	-	85	°C	3
Life time(100cd/m ²)	-	15,000	-	-	hour	4
Humidity	-	-	-	90	%RH	-

Note 1: All the above voltages are on the basis of "V_{SS} = 0V".

Note 2: When this module is used beyond the above absolute maximum ratings, permanent breakage of the module may occur. Also, for normal operations, it is desirable to use this module under the conditions according to electro-optical characteristics. If this module is used beyond these conditions, malfunctioning of the module can occur and the reliability of the module may deteriorate.

Note 3: The defined temperature ranges do not include the polarizer. The maximum withstood temperature of the polarizer should be 80°C.

Note 4: V_{CC_C} = 12.0V, T_a = 25°C, 50% Checkerboard.

Software configuration follows Actual Application Example.

End of lifetime is specified as 50% of initial brightness reached. The average operating lifetime at room temperature is estimated by the accelerated operation at high temperature conditions.

■ ELECTRICAL CHARACTERISTICS

◆ DC Characteristics

Items	Symbol	Conditions	Min	Typ.	Max	Unit
Supply voltage for operation	V_{DD}		2.4	2.8	3.3	V
Supply voltage for I/O pins	V_{DDIO}		1.65	1.8	V_{DD}	V
Supply voltage for display	V_{CC_C}	Note 5	11.5	12	12.5	V
High level input	V_{IH}		$0.8 \times V_{DD}$	-	V_{DD}	V
Low level input	V_{IL}		0	-	0.4	V
High level output	V_{OH}	$I_{OH} = 0.1\text{mA}$	$V_{DD} - 0.4$	-	-	V
Low level output	V_{OL}	$I_{OL} = 0.1\text{mA}$	-	-	0.4	V
Operating current for V_{DD}	I_{DD}		-	1.5	3.5	mA
Operating current for V_{CC_C}	I_{CC_C}	Note 6	-	6.4	8.0	mA
		Note 7	-	9.5	12.0	mA
		Note 8	-	16.0	20.0	mA
Sleep mode current for V_{DD}	$I_{DD,SLEEP}$		-	3	5	μA
Sleep mode current for V_{CC_C}	$I_{CC_C,SLEEP}$		-	1	5	μA

Note 5: Supply Voltage for Display (V_{CC_C}) are subject to the change of the panel characteristics and the customer's request.

Note 6: $V_{DD} = 2.8\text{V}$, $V_{CC_C} = 12.0\text{V}$, 30% Display Area Turn on.

Note 7: $V_{DD} = 2.8\text{V}$, $V_{CC_C} = 12.0\text{V}$, 50% Display Area Turn on.

Note 8: $V_{DD} = 2.8\text{V}$, $V_{CC_C} = 12.0\text{V}$, 100% Display Area Turn on.

* Software configuration follows Actual Application Example .

◆ AC Characteristics

1. 80XX-Series MPU Parallel Interface Timing Characteristics:

($V_{DD} = 2.8V, T_a = 25^\circ C$)

Symbol	Description	Min	Max	Unit	Port
t_{AS8}	Address Setup Timing	5	-	ns	CSB A0
t_{AH8}	Address Hold Timing	5	-	ns	
t_{CYC8}	System Cycle Timing	200	-	ns	RDB
t_{RDLR8}	Read "L" Pulse Width	90	-	ns	
t_{RDHR8}	Read "H" Pulse Width	90	-	ns	
t_{CYC8}	System Cycle Timing	100	-	ns	WRB
t_{WRLW8}	Write "L" Pulse Width	45	-	ns	
t_{WRHW8}	Write "H" Pulse Width	45	-	ns	
t_{RDD8}	Read Data Output Delay Time	-	60	ns	D[7:0]
t_{RDH8}	Data Hold Timing	0	60	ns	
t_{DS8}	Data Setup Timing	30	-	ns	
t_{DH8}	Data Hold Timing	10	-	ns	

* All the timing reference is 10% and 90% of V

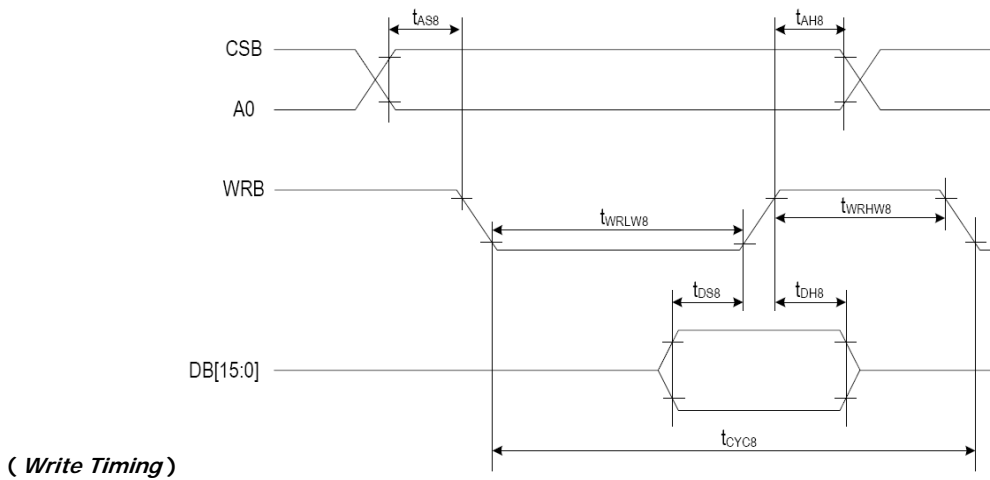
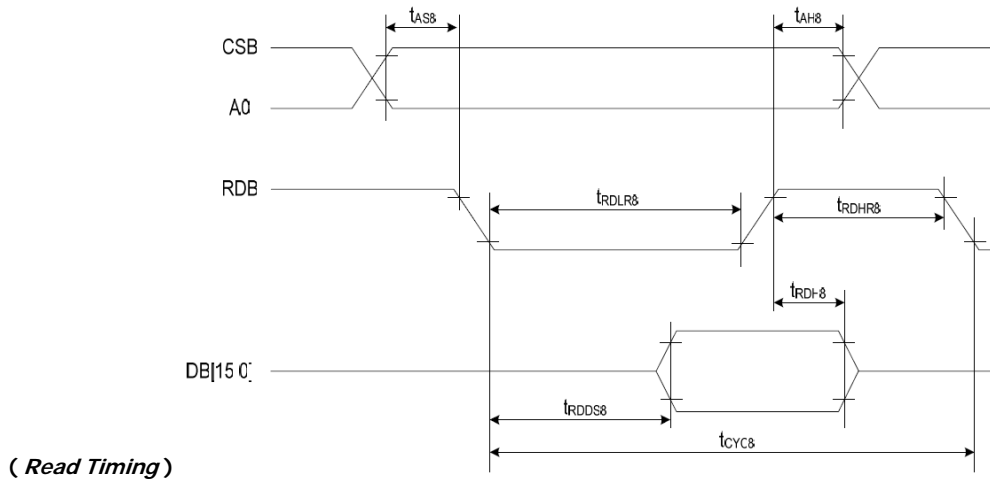

2. 68XX-Series MPU Parallel Interface Timing Characteristics:

 $(V_{DD} = 2.8V, T_a = 25^\circ C)$

Symbol	Description	Min	Max	Unit	Port	
t_{AH6}	Address Setup Timing	(Read)	10	-	ns	CSB RS
		(Write)	5	-	ns	
t_{AS6}	Address Hold Timing	(Read)	10	-	ns	
		(Write)	5	-	ns	
t_{CYC6}	System Cycle Timing	200	-	ns	E	
t_{ELR6}	Read "L" Pulse Width	90	-	ns		
t_{EHR6}	Read "H" Pulse Width	90	-	ns		
t_{CYC6}	System Cycle Timing	100	-	ns		
t_{ELW6}	Write "L" Pulse Width	45	-	ns		
t_{EHW6}	Write "H" Pulse Width	45	-	ns	D[7:0]	
t_{RDD6}	Read Data Output Delay Time * $CL = 15pF$	0	70	ns		
t_{RDH6}	Data Hold Timing	0	70	ns		
t	Data Setup Timing	40	-	ns		
t_{DH6}	Data Hold Timing	10	-	ns		

* All the timing reference is 10% and 90% of V

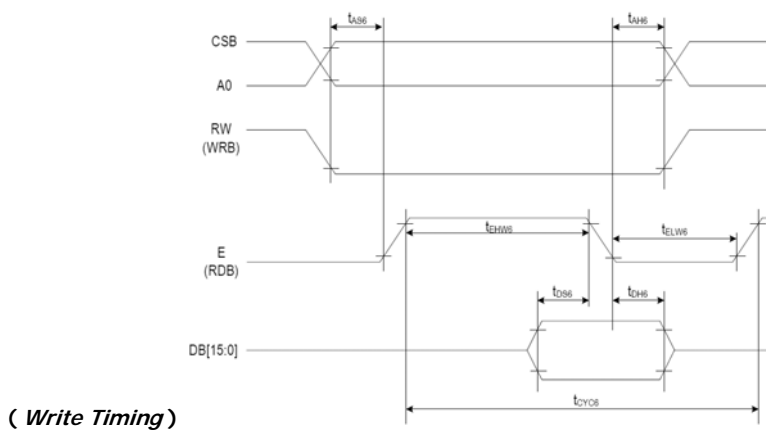
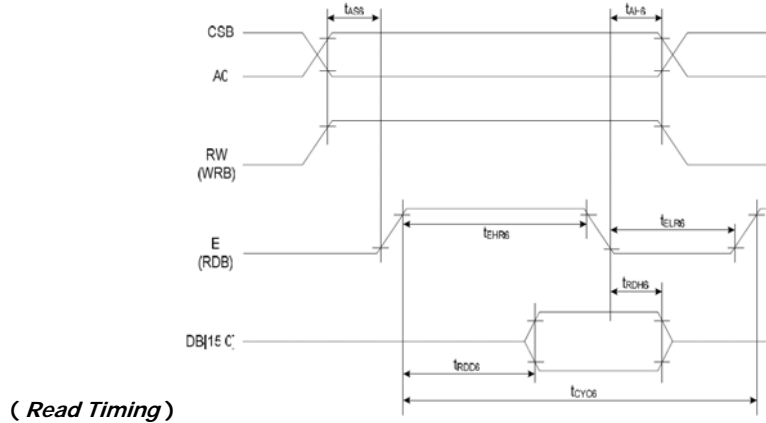

3. Serial Interface Timing Characteristics:

 $(V_{DD} = 2.8V, T_a = 25^\circ C)$

Symbol	Description	Min	Max	Unit	Port
t_{CYCS}	Serial Clock Cycle	200	-	ns	SCL
t_{SLW}	SCL "L" Pulse Width	90	-	ns	
t_{SHW}	SCL "H" Pulse Width	90	-	ns	
t_{DSS}	Data Setup Timing	25	-	ns	SDI
t_{DHS}	Data Hold Timing	25	-	ns	
t_{CSS}	CSB-SCL Timing	25	-	ns	CSB
t_{CSH}	CSB-Hold Timing	25	-	ns	
t_{RSS}	RS-SCL Timing	25	-	ns	A0
t_{RSH}	RS-Hold Timing	25	-	ns	

* All the timing reference is 10% and 90% of V_{DDIO} .

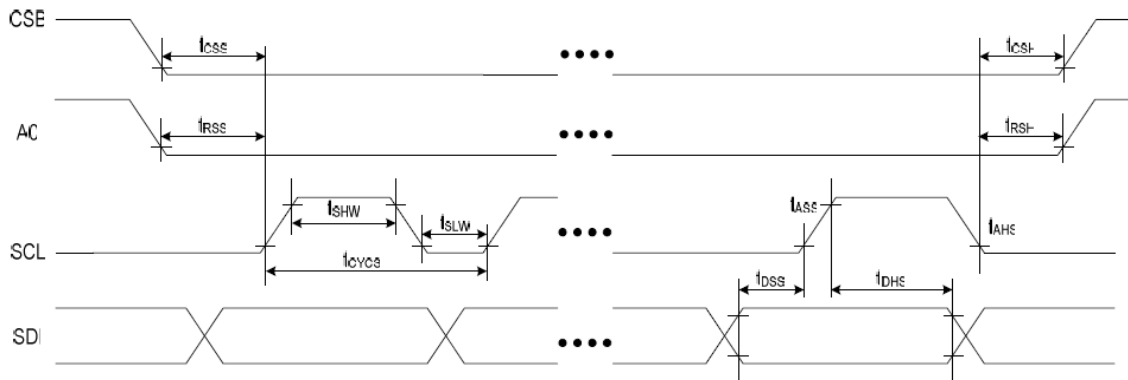

■ TIMING OF POWER SUPPLY

1. Commands

Refer to the Technical Manual for the SEPS114A

2. Power down and Power up Sequence

To protect OEL panel and extend the panel life time, the driver IC power up/down routine should include a delay period between high voltage and low voltage power sources during turn on/off. It gives the OEL panel enough time to complete the action of charge and discharge before/after the operation.

1.1 Power up Sequence:

1. Power up V_{DD} & V_{DDIO}
2. Send Display off command
3. Initialization
4. Clear Screen
5. Power up V_{CC_C}
6. Delay 100ms
(When V_{CC_C} is stable)
7. Send Display on command

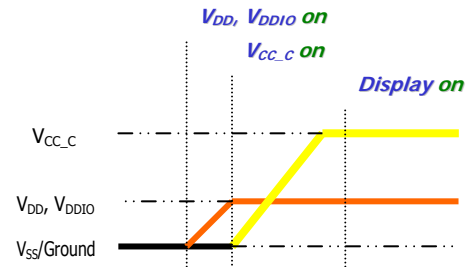

1.2 Power down Sequence:

1. Send Display off command
2. Power down V_{CC_C}
3. Delay 100ms
(When V_{CC_C} is reach 0 and panel is completely discharges)
4. Power down V_{DD} & V_{DDIO}

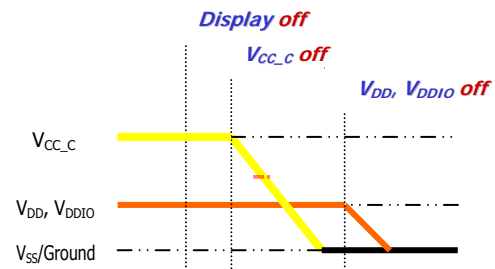

Note 9:

- 1) Since an ESD protection circuit is connected between V_{DD} , V_{DDIO} and V_{CC_C} inside the driver IC, V_{CC_C} becomes lower than V_{DD} & V_{DDIO} whenever V_{DD} & V_{DDIO} is ON and V_{CC_C} is OFF.
- 2) V_{CC_C} should be kept float (disable) when it is OFF.
- 3) Power Pins (V_{DD} , V_{DDIO} , V_{CC_C}) can never be pulled to ground under any circumstance.
- 4) V_{DD} & V_{DDIO} should not be power down before V_{CC_C} power down.

3. Reset Circuit

When RSTB input is low, the chip is initialized with the following status:

1. Standby Mode: On
2. Frame Frequency: 95Hz
3. Oscillation: Internal Oscillator Off
4. DDRAM Write Horizontal Address: XS = 0x00, XE = 0x5F
5. DDRAM Write Vertical Address: YS = 0x00, YE = 0x5F
6. Display Data RAM Write: MDIR1 = 0, MDIRO = 0, VH = 0
7. Row Scan Shift Direction: R0, R1, ... , R94, R95
8. Column Data Shift Direction: C0, C1, ... , C286, C287
9. Display On/Off: Off
10. Panel Display Size: FX = 0x00, TX = 0x5F, FY = 0x00, TY = 0x5F
11. Display Data RAM Read Column/Row Address: DX = 0x00, DY = 0x00
12. Discharge Time: 8 Clock
13. Peak Pulse Delay: 5 Clock
14. Peak Pulse Width Time (R/G/B): 5 Clock
15. Precharge Current (R/G/B): 0 μ A
16. Driving Current (R/G/B): 0 μ A

4. Actual Application Example

Command usage and explanation of an actual example

<Power up Sequence>

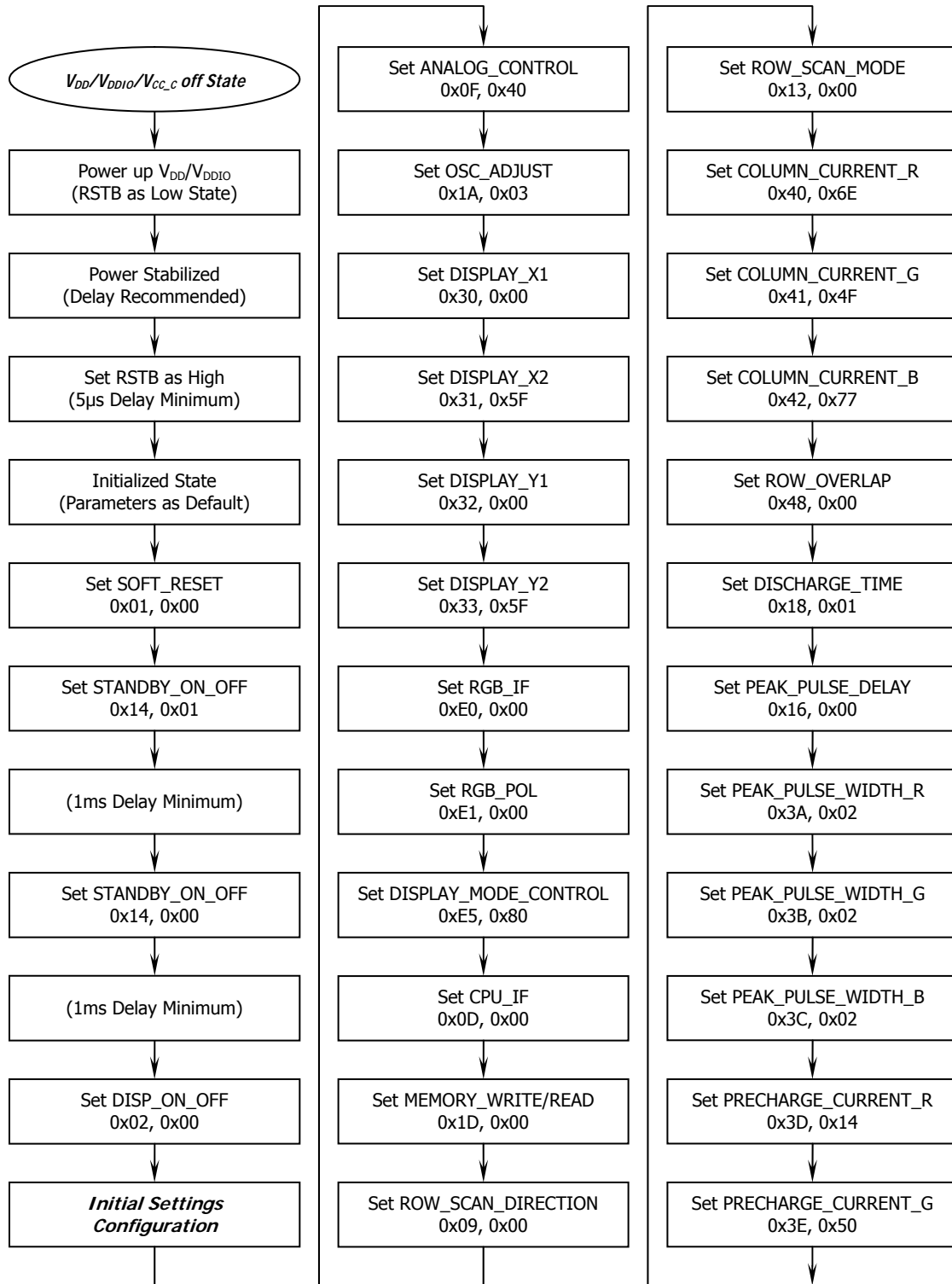

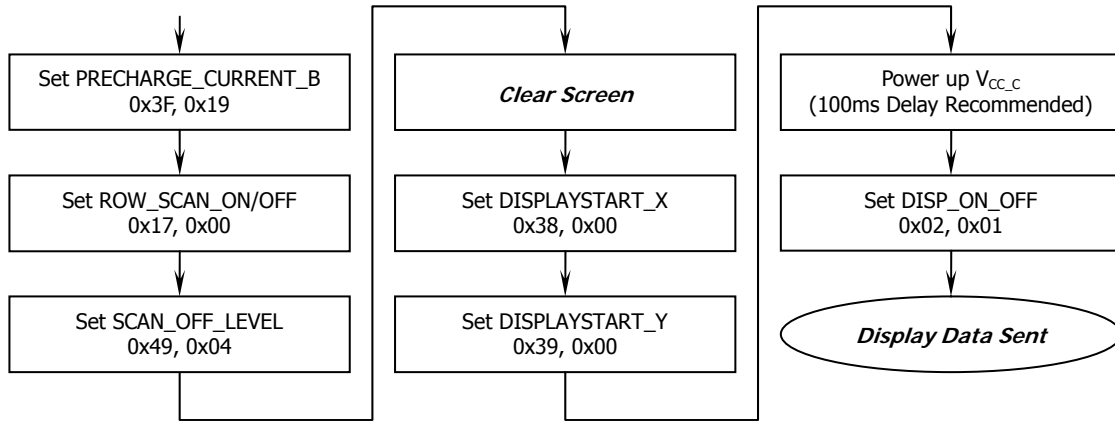

If the noise is accidentally occurred at the displaying window during the operation, please reset the display in order to recover the display function.

<Power down Sequence>

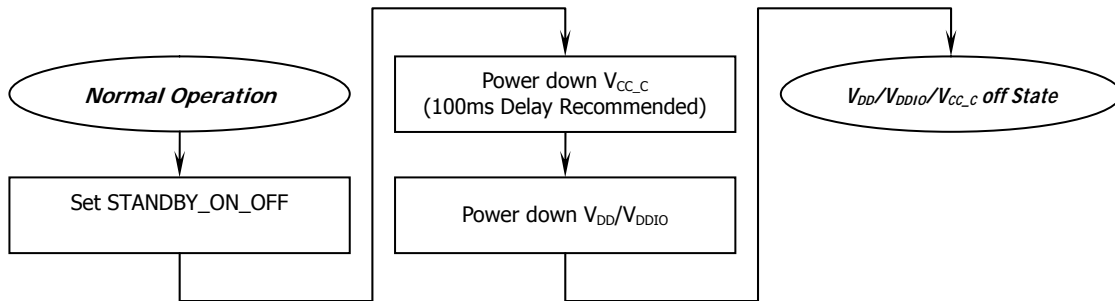

<Entering Sleep Mode>

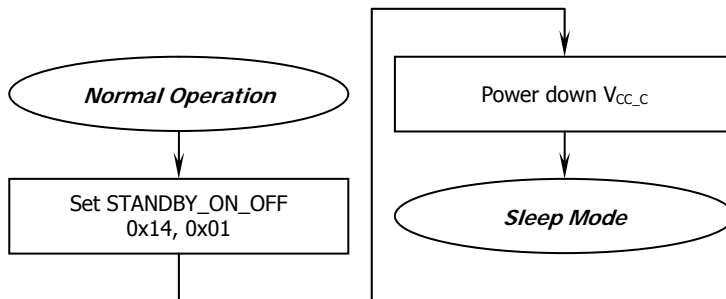

<Exiting Sleep Mode>

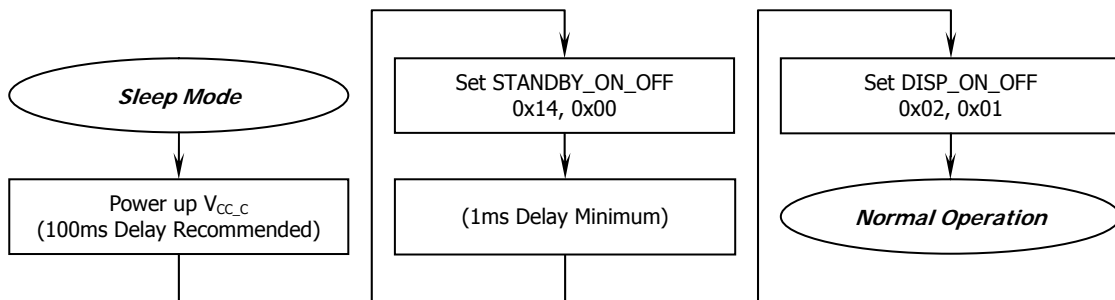

■ ELECTRO-OPTICAL CHARACTERISTICS (Ta=25°C)

Items		Symbol	Min.	Typ.	Max.	Unit	Remark
Operating Luminance		L	80	100	-	cd /m ²	White
Power Consumption		P	-	-	-	mW	30% pixels ON L=110cd/m ²
Frame Frequency		Fr	-	-	-	Hz	
Color Coordinate	White	CIE x	0.26	0.30	0.34	CIE1931	Darkroom
		CIE y	0.29	0.33	0.37		
Color Coordinate	Red	CIE x	0.60	0.64	0.68	CIE1931	Darkroom
		CIE y	0.30	0.34	0.38		
Color Coordinate	Green	CIE x	0.27	0.31	0.35	CIE1931	Darkroom
		CIE y	0.58	0.62	0.66		
Color Coordinate	Blue	CIE x	0.10	0.14	0.18	CIE1931	Darkroom
		CIE y	0.12	0.16	0.20		
Response Time	Rise	Tr	-	-	-	ms	-
	Decay	Td	-	-	-	ms	-
Contrast Ratio*		Cr	10000 :1	-	-		Darkroom
Viewing Angle Uniformity		$\Delta \theta$	-	Free	-	Degree	-

Note : Brightness (L_{br}) is subject to the change of the panel characteristics and the customer' s request.

* Optical measurement taken at V_{DD} = 2.8V, V_{CC_C} = 12.0V.

Software configuration follows Actual Application Example .

■ INTERFACE PIN CONNECTIONS

1. Block Diagram

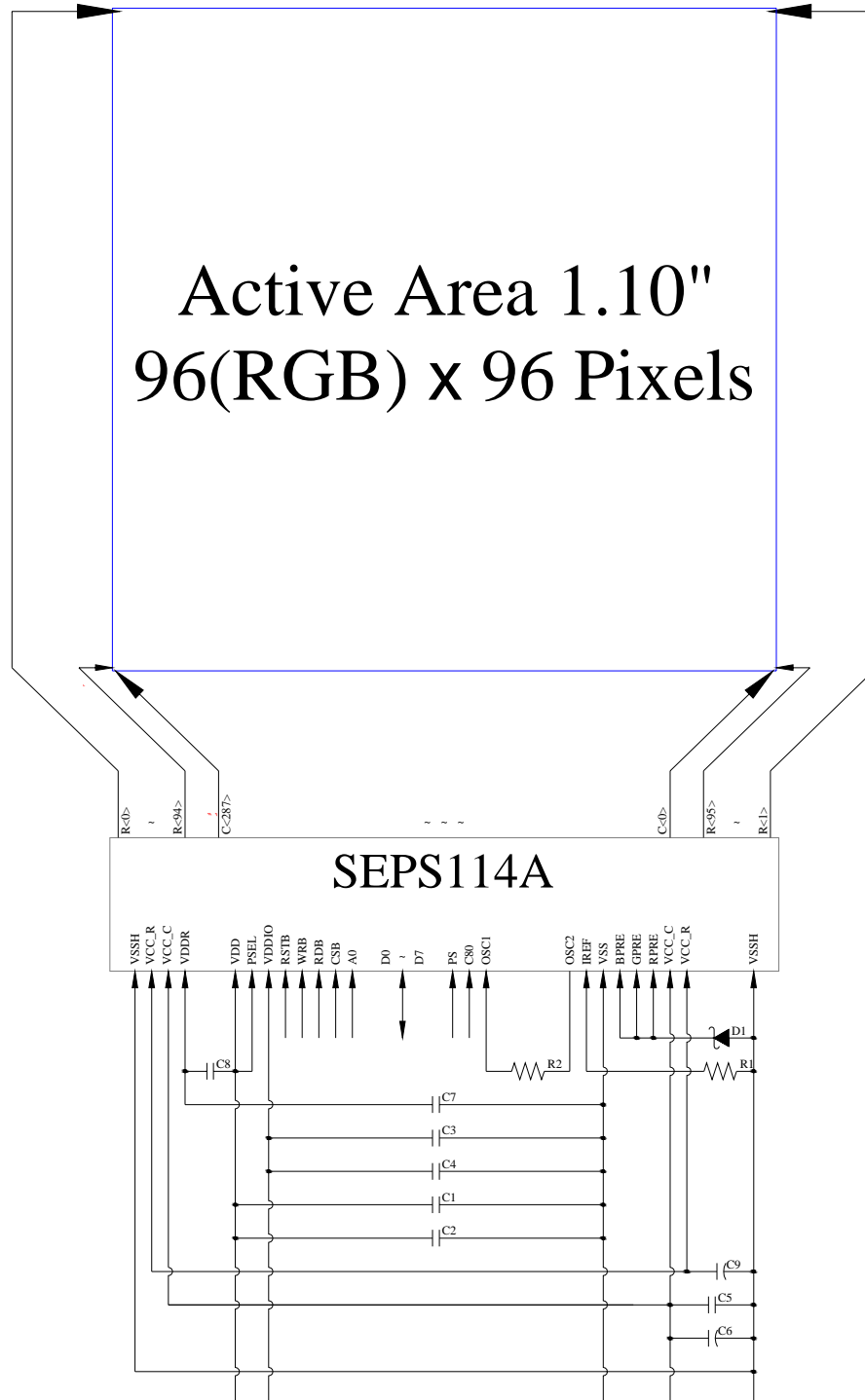

MCU Interface Selection: PS, C80
 Pins connected to MCU interface: RSTB, WRB, RDB, CSB, A0, and D0~D7

C1, C3, C5: 0.1 μ F
 C2, C4, C8: 4.7 μ F
 C6, C9: 4.7 μ F / 25V Tantalum Capacitor
 C7: 2.2 μ F
 R1: 39k Ω
 R2: 27k Ω
 D1: 2.7V, 0.5W Zener Diode

2. Pin Definition

Pin Number	Symbol	I/O	Function
Power Supply			
6	VDD	P	Power Supply for Operation This is a voltage supply pin. It must be connected to external source.
5	VDDR	P	Power Supply for Core Logic Circuit This is a voltage supply pin. It can be supplied externally or regulated internally from V _{DD} . A capacitor should be connected between this pin & V _{SS} under all circumstances.
8	VDDIO	P	Power Supply for I/O Pin This pin is a power supply pin of I/O buffer. It should be connected to V _{DD} or external source. All I/O signal should have V _{IH} reference to V _{VDDIO} . When I/O signal pins (C80, PS, D0~D7, control signals...) pull high, they should be connected to V _{VDDIO} .
27	VSS	P	Ground of Logic Circuit This is a ground pin. It also acts as a reference for the logic pins. It must be connected to external ground.
4, 31	VCC_C	P	Power Supply for OEL Panel This is the most positive voltage supply pin of the chip. It must be connected to external source.
2, 33	VSSH	P	Ground of OEL Panel This is the ground pins for analog circuits. It must be connected to external ground.
Driver			
30 29 28	RPRE GPRE BPRE	I/O	External Voltage Reference for Pre charge Signal This is the precharge driving voltages for OEL driving segment pins respectively. A zener diode should be connected between this pin and V _{SS} .
26	IREF	I/O	Current Reference for Brightness Adjustment This is the current reference pin to generate precharge and driving current. A 39kΩ resistor should be connected between this pin and V _{SS} .
3, 32	VCC_R	P	Voltage Output High Level for Scan Signal This is the scan driver power supply pin. A tantalum capacitor should be connected between this pin and V _{SS} .
Clock			
24 25	OSC1 OSC2	I O	Fine Adjustment for Oscillation The frequency is controlled by external 27kΩ resistor between OSC1 and OSC2. The oscillator signal is used for system clock generation. When the external clock mode is selected, OSC1 is used external clock input.
Configuration			
7	PSEL	I	Regulator Enable/Disable for Logic Power Supply This pin is the regulator enable/disable input of V _{VDDR} . If it is connected to V _{VDD} , the internal regulator is used. Otherwise, an external voltage supplier should be used.
Interface			
23	C80	I	Select the CPU Type Low: 80XX-Series MCU High: 68XX-Series MCU.
22	PS	I	Select Parallel/Serial Interface Type Low: Serial Interface High: Parallel Interface
9	RSTB	I	Power Reset for Controller and Driver This pin is reset signal input. When the pin is low, initialization of the chip is executed.
12	CSB	I	Chip Select Low: SEPS114A is selected and can be accessed. High: SEPS114A is not selected and cannot be accessed.
13	A0	I	Data/Command Control Low: Command High: Parameter/Data

Pin Number	Symbol	I/O	Function						
Interface (Continued)									
11	RDB	I	Read or Read/Write Enable 68XX Parallel Interface: Bus Enabled Strobe (Active High) 80XX Parallel Interface: Read Strobe Signal (Active Low) While using SPI, it must be connected to V_{DD} or V_{SS} .						
10	WRB	I	Write or Read/Write Select 68XX Parallel Interface: Read (Low)/Write (High) Select 80XX Parallel Interface: Write Strobe Signal (Active Low) While using SPI, it must be connected to V_{DD} or V_{SS} .						
14~21	D0~D7	I/O	Host Data Input/Output Bus These pins are 8-bit bi-directional data bus to be connected to the microprocessor's data bus. <table border="1" data-bbox="635 683 1262 846"> <thead> <tr> <th>PS</th> <th>Description</th> </tr> </thead> <tbody> <tr> <td>0</td> <td>D[0] SCL: Synchronous Clock Input D[1] SDI: Serial Data Input D[2] SDO: Serial Data Output D[3] R/W: Serial Read (High)/Write (Low)</td> </tr> <tr> <td>1</td> <td>8-bit Bus: D[7:0]</td> </tr> </tbody> </table> While using SPI, the unused pins must be connected to V_{SS} .	PS	Description	0	D[0] SCL: Synchronous Clock Input D[1] SDI: Serial Data Input D[2] SDO: Serial Data Output D[3] R/W: Serial Read (High)/Write (Low)	1	8-bit Bus: D[7:0]
PS	Description								
0	D[0] SCL: Synchronous Clock Input D[1] SDI: Serial Data Input D[2] SDO: Serial Data Output D[3] R/W: Serial Read (High)/Write (Low)								
1	8-bit Bus: D[7:0]								
Reserve									
1, 34	N.C. (GND)	-	Reserved Pin (Supporting Pin) The supporting pins can reduce the influences from stresses on the function pins. These pins must be connected to external ground as the ESD protection circuit.						

■ RELIABILITY TESTS

Item		Condition	Criterion
High Temperature Storage (HTS)		85±2℃, 240 hours	1. After testing, the function test is ok. 2. After testing, no addition to the defect. 3. After testing, the change of luminance should be within +/- 50% of initial value. 4. After testing, the change for the mono and area color must be within (+/-0.02, +/- 0.02) and for the full color it must be within (+/-0.04, +/-0.04) of initial value based on 1931 CIE coordinates. 5. After testing, the change of total current consumption should be within +/- 50% of initial value.
High Temperature Operating (HTO)		70±2℃, 240 hours	
Low Temperature Storage (LTS)		-40±2℃, 240 hours	
Low Temperature Operating (LTO)		-40±2℃, 240 hours	
High Temperature / High Humidity Storage (HTHHS)		60±3℃, 90%±3%RH, 120 hours	
Thermal Shock (Non-operation) (TS)		-40±2℃ ~ 25℃ ~ 85±2℃ (30min) (5min) (30min) 24cycles	
Vibration (Packing)	10~55~10Hz, amplitude 1.5mm, 1 hour for each direction x, y, z	1. One box for each test. 2. No addition to the cosmetic and the electrical defects.	
Drop (Packing)	Height : 1 m, each time for 6 sides, 3 edges, 1 angle		

Note: 1) For each reliability test, the sample quantity is 3, and only for one test item.
 2) The HTHHS test is requested the Pure Water(Resistance > 10MΩ).

■ OUTGOING QUALITY CONTROL SPECIFICATION

◆ Standard

According to GB/T2828.1-2003/ISO 2859-1: 1999 and ANSI/ASQC Z1.4-1993, General Inspection Level II.

◆ Definition

- 1 Major defect : The defect that greatly affect the usability of product.
- 2 Minor defect : The other defects, such as cosmetic defects, etc.
- 3 Definition of inspection zone:

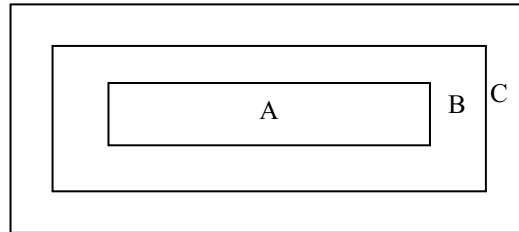

Zone A: Active Area

Zone B: Viewing Area except Zone A

Zone C: Outside Viewing Area

Note: As a general rule, visual defects in Zone C are permissible, when it is no trouble of quality and assembly to customer`s product.

◆ Inspection Methods

- 1 The general inspection : under 20W x 2 or 40W fluorescent light, about 30cm viewing distance, within 45° viewing angle, under 25±5°C.

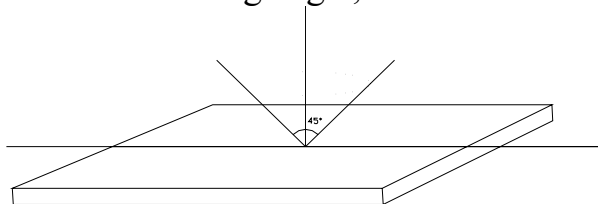

- 2 The luminance and color coordinate inspection : By PR705 or BM-7 or the equal equipments, in the dark room, under 25±5°C.

◆ Inspection Criteria

- 1 Major defect : AQL= 0.65

Item	Criterion
Function Defect	1. No display or abnormal display is not accepted
	2. Open or short is not accepted.
	3. Power consumption exceeding the spec is not accepted.
Outline Dimension	Outline dimension exceeding the spec is not accepted.
Glass Crack	Glass crack tends to enlarge is not accepted.

- 2 Minor Defect : AQL= 1.5

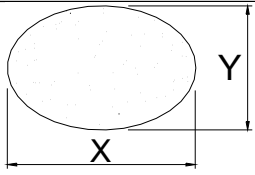
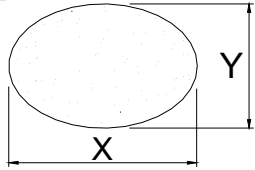
Item	Criterion			
Spot Defect (dimming and lighting spot)	Size (mm)		Accepted Qty	
			Area A + Area B	Area C
		$\Phi \leq 0.10$	Ignored	
		$0.10 < \Phi \leq 0.15$	3	Ignored
		$0.15 < \Phi \leq 0.20$	1	
$0.20 < \Phi$		0		
Note : $\Phi = (x + y) / 2$				
Line Defect (dimming and lighting line)	L (Length) : mm	W (Width) : mm	Area A + Area B	Area C
	/	$W \leq 0.03$	Ignored	
	$L \leq 3.0$	$0.03 < W \leq 0.05$	2	Ignored
	$L \leq 2.0$	$0.05 < W \leq 0.08$	1	
	/	$0.08 < W$	As spot defect	
Remarks: The total of spot defect and line defect shall not exceed 4 pcs.				
Polarizer Stain	Stain which can be wiped off lightly with a soft cloth or similar cleaning is accepted, otherwise, according to the Spot Defect and the Line Defect.			
Polarizer Scratch	1. If scratch can be seen during operation, according to the criterions of the Spot Defect and the Line Defect.			
	2. If scratch can be seen only under non-operation or some special angle, the criterion is as below :			
	L (Length) : mm	W (Width) : mm	Area A + Area B	Area C
	/	$W \leq 0.03$	Ignore	
	$5.0 < L \leq 10.0$	$0.03 < W \leq 0.05$	2	Ignore
	$L \leq 5.0$	$0.05 < W \leq 0.08$	1	
/	$0.08 < W$	0		
Polarizer Air Bubble	Size		Area A + Area B	Area C
		$\Phi \leq 0.20$	Ignored	
		$0.20 < \Phi \leq 0.50$	2	Ignored
		$0.50 < \Phi \leq 0.80$	1	
		$0.80 < \Phi$	0	

Glass Defect (Glass Chipped)	1. On the corner	(mm)	<table border="1"> <tr> <td>x</td> <td>≤ 2.0</td> </tr> <tr> <td>y</td> <td>$\leq S$</td> </tr> <tr> <td>z</td> <td>$\leq t$</td> </tr> </table>	x	≤ 2.0	y	$\leq S$	z	$\leq t$
	x	≤ 2.0							
	y	$\leq S$							
	z	$\leq t$							
2. On the bonding edge	(mm)	<table border="1"> <tr> <td>x</td> <td>$\leq a / 2$</td> </tr> <tr> <td>y</td> <td>$\leq s / 3$</td> </tr> <tr> <td>z</td> <td>$\leq t$</td> </tr> </table>	x	$\leq a / 2$	y	$\leq s / 3$	z	$\leq t$	
x	$\leq a / 2$								
y	$\leq s / 3$								
z	$\leq t$								
3. On the other edges	(mm)	<table border="1"> <tr> <td>x</td> <td>$\leq a / 5$</td> </tr> <tr> <td>y</td> <td>≤ 1.0</td> </tr> <tr> <td>z</td> <td>$\leq t$</td> </tr> </table>	x	$\leq a / 5$	y	≤ 1.0	z	$\leq t$	
x	$\leq a / 5$								
y	≤ 1.0								
z	$\leq t$								
	Note: t: glass thickness ; s: pad width ; a: the length of the edge								
TCP Defect	Crack, deep fold and deep pressure mark on the TCP are not accepted								
Pixel Size	The tolerance of display pixel dimension should be within $\pm 20\%$ of the spec								
Luminance	Refer to the spec or the reference sample								
Color	Refer to the spec or the reference sample								

■ CAUTIONS IN USING OLED MODULE

◆ Precautions For Handling OLED Module:

1. OLED module consists of glass and polarizer. Pay attention to the following items when handling:
 - i. Avoid drop from high, avoid excessive impact and pressure.
 - ii. Do not touch, push or rub the exposed polarizers with anything harder than an HB pencil lead.
 - iii. If the surface becomes dirty, breathe on the surface and gently wipe it off with a soft dry cloth. If it is terrible dirty, moisten the soft cloth with Isopropyl alcohol or Ethyl alcohol. Other solvents may damage the polarizer. Especially water, Ketone and Aromatic solvents.
 - iv. Wipe off saliva or water drops immediately, contact the polarizer with water over a long period of time may cause deformation.
 - v. Please keep the temperature within specified range for use and storage. Polarization degradation, bubble generation or polarizer peeling-off may occur with high temperature and high humidity.
 - vi. Condensation on the surface and the terminals due to cold or anything will damage, stain or dirty the polarizer, so make it clean as the way of iii.
2. Do not attempt to disassemble or process the OLED Module.
3. Make sure the TCP or the FPC of the Module is free of twisting, warping and distortion, do not pull or bend them forcefully, especially the soldering pins. On the other side, the SLIT part of the TCP is made to bend in the necessary case.
4. When assembling the module into other equipment, give the glass enough space to avoid excessive pressure on the glass, especially the glass cover which is much more fragile.
5. Be sure to keep the air pressure under 120 kPa, otherwise the glass cover is to be cracked.
6. Be careful to prevent damage by static electricity:
 - i. Be sure to ground the body when handling the OLED Modules.
 - ii. All machines and tools required for assembling, such as soldering irons, must be properly grounded.
 - iii. Do not assemble and do no other work under dry conditions to reduce the amount of static electricity generated. A relative humidity of 50%-60% is recommended.
 - iv. Peel off the protective film slowly to avoid the amount of static electricity generated.
 - v. Avoid to touch the circuit, the soldering pins and the IC on the Module by the body.
 - vi. Be sure to use anti-static package.
7. Contamination on terminals can cause an electrochemical reaction and corrode the terminal circuit, so make it clean anytime.
8. All terminals should be open, do not attach any conductor or semiconductor on the terminals.
9. When the logic circuit power is off, do not apply the input signals.
10. Power on sequence: $V_{DD} \rightarrow V_{PP}$, and power off sequence: $V_{PP} \rightarrow V_{DD}$.
11. Be sure to keep temperature, humidity and voltage within the ranges of the spec, otherwise shorten Module's life time, even make it damaged.
12. Be sure to drive the OLED Module following the Specification and Datasheet of IC controller, otherwise something wrong may be seen.

13. When displaying images, keep them rolling, and avoid one fixed image displaying more than 30 seconds, otherwise the residue image is to be seen. This is the speciality of OLED.

◆ **Precautions For Soldering OLED Module:**

1. Soldering temperature : $260^{\circ}\text{C} \pm 10^{\circ}\text{C}$.
2. Soldering time : 3-4 sec.
3. Repeating time : no more than 3 times.
4. If soldering flux is used, be sure to remove any remaining flux after finishing soldering operation. (This does not apply in the case of a non-halogen type of flux.) It is recommended to protect the surface with a cover during soldering to prevent any damage due to flux spatters.

◆ **Precautions For Storing OLED Module:**

1. Be sure to store the OLED Module in the vacuum bag with dessicant.
2. If the Module can not be used up in 1 month after the bag being opened, make sure to seal the Module in the vacuum bag with dessicant again.
3. Store the Module in a dark place, do not expose to sunlight or fluorescent light.
4. The polarizer surface should not touch any other objects. It is recommended to store the Module in the shipping container.
5. It is recommended to keep the temperature between 0°C and 30°C , the relative humidity not over 60%.

◆ **Limited Warranty**

Unless relevant quality agreements signed with customer and law enforcement, for a period of 12 months from date of production, all products (except automotive products) Multi-Inno will replace or repair any of its OLED modules which are found to be functional defect when inspected in accordance with Multi-Inno OLED acceptance standards (copies available upon request). Cosmetic/visual defects must be returned to Multi-Inno within 90 days of shipment. Confirmation of such date should be based on freight documents. The warranty liability of Multi-Inno is limited to repair and/or replacement on the terms above. Multi-Inno will not be responsible for any subsequent or consequential events.

◆ **Return OLED Module Under Warranty:**

1. No warranty in the case that the precautions are disregarded.
2. Module repairs will be invoiced to the customer upon mutual agreement. Modules must be returned with sufficient description of the failures or defects.