

EXAMINED BY :	EMERGING DISPLAY TECHNOLOGIES CORPORATION	FILE NO . CAS-0008231
<i>Kevin kuo</i>		ISSUE : MAR.01, 2016
APPROVED BY:		TOTAL PAGE : 31
<i>Chris Wu</i>		VERSION : 1

CUSTOMER ACCEPTANCE SPECIFICATIONS

MODEL NO. :

ETM057010EDHU

(RoHS)

FOR MESSRS : \_\_\_\_\_

CUSTOMER'S APPROVAL

DATE : \_\_\_\_\_

BY : \_\_\_\_\_

EMERGING DISPLAY  
TECHNOLOGIES CORPORATION

MODEL NO.	VERSION	PAGE
ETM057010EDHU	1	0-1

RECORDS OF REVISION	DOC . FIRST ISSUE	MAR.01, 2016
---------------------	-------------------	--------------

DATE	REVISED PAGE NO.	SUMMARY
<p>CONFIDENTIAL</p> <p>Authorized for</p> <p>Emerging Display Technologies Corporation Only.</p> <p>Do not distribute without authorization.</p>		

TABLE OF CONTENTS

NO.	ITEM	PAGE
1.	GENERAL SPECIFICATIONS -----	1
2.	MECHANICAL SPECIFICATIONS -----	1, 2
3.	ABSOLUTE MAXIMUM RATINGS -----	3
4.	ELECTRICAL CHARACTERISTICS -----	4
5.	TIMING CHARACTERISTICS -----	5 ~ 8
6.	OPTICAL CHARACTERISTICS -----	9, 10
7.	OUTLINE DIMENSIONS -----	11
8.	BLOCK DIAGRAM -----	12
9.	DETAIL DRAWING OF DOT MATRIX -----	13
10.	INTERFACE SIGNALS -----	14, 15
11.	POWER SUPPLY -----	16
12.	CAPACITIVE TOUCH PANEL SPECIFICATION -----	17 ~ 21
13.	INSPECTION CRITERION -----	22 ~ 31

CONFIDENTIAL  
Authorized for  
Emerging Display Technologies Corporation Only.  
Do not distribute without authorization.

1. GENERAL SPECIFICATIONS

1.1 DATA SHEETS FOR LCD PANEL CONTROLLER/DRIVER  
PLEASE REFER TO :

HIMAX HX8250  
HIMAX HX8678

1.2 DATA SHEETS FOR CAPACITIVE TOUCH PANEL  
CONTROLLER/DRIVER PLEASE REFER TO :

HYCON HY4614

1.3 MATERIAL SAFETY DESCRIPTION  
ASSEMBLIES SHALL COMPLY WITH EUROPEAN ROHS REQUIREMENTS,  
INCLUDING PROHIBITED MATERIALS/COMPONENTS CONTAINING LEAD,  
MERCURY, CADMIUM, HEXAVALENT CHROMIUM, POLYBROMINATED  
BIPHENYLS (PBB) AND POLYBROMINATED  
DIPHENYL ETHERS (PBDE)

2. MECHANICAL SPECIFICATIONS

2.1 TFT LCD MODULE MECHANICAL SPECIFICATIONS

- (1) DIAGONALS ----- 5.7 inch
- (2) NUMBER OF DOTS ----- 640W \* (RGB) \* 480H DOTS
- (3) MODULE SIZE ----- 147.6W \* 100.0H \* 11.7D (MAX) mm  
(WITHOUT FPC)
- (4) VIEWING AREA ----- 117.2W \* 88.4H mm
- (5) ACTIVE AREA ----- 115.2W \* 86.4H mm
- (6) DOT SIZE ----- 0.06W \* 0.18H mm
- (7) PIXEL SIZE ----- 0.18W \* 0.18H mm
- (8) LCD TYPE ----- TFT , TRANSMISSIVE
- (9) COLOR ----- 16.7M
- (10) VIEWING DIRECTION ----- 12 O'CLOCK (GRAY LEVEL INVERSION)
- (11) BACK LIGHT ----- LED , COLOR : WHITE
- (12) INTERFACE MODE ----- RGB 24BIT PARALLEL (DE/SYNC MODE)

MODEL NO.	VERSION	PAGE
ETM057010EDHU	1	2

## 2.2 CAPACITIVE TOUCH PANEL MECHANICAL SPECIFICATIONS

- (1) TOUCH PANEL SIZE ----- 5.7 inch
- (2) OUTER DIMENSION ----- 124.7W \* 100H \* 1.40D mm  
(WITHOUT FPC)
- (3) ACTIVE AREA ----- 116.57W \* 88.77H mm
- (4) INPUT TYPE ----- MULTI-TOUCH
- (5) NUMBER OF TOUCH SENSOR ----- 22\*16 SENSORS
- (6) INTERFACE MODE ----- I2C
- (7) RESOLUTION ----- 1408\*1024

CONFIDENTIAL  
Authorized for  
Emerging Display Technologies Corporation Only.  
Do not distribute without authorization.

### 3. ABSOLUTE MAXIMUM RATINGS

#### 3.1 LCD MODULE ELECTRICAL ABSOLUTE MAXIMUM RATINGS

VSS=0V

PARAMETER	SYMBOL	MIN.	MAX.	UNIT	REMARK
POWER SUPPLY VOLTAGE	VCC	-0.3	7.0	V	
	VDD	-0.3	7.0	V	
INPUT VOLTAGE	V <sub>in</sub>	-0.3	VCC+0.3	V	
LED BACKLIGHT DISSIPATION	PD	—	1.28	W	
LED BACKLIGHT CURRENT	IF	—	0.06	A	
LED BACKLIGHT REVERSE VOLTAGE	VR	—	45	V	

#### 3.2 CAPACITIVE TOUCH PANEL ELECTRICAL ABSOLUTE MAXIMUM RATINGS

PARAMETER	SYMBOL	MIN.	MAX.	UNIT	REMARK
POWER SUPPLY FOR DRIVER	VDD1-VSS1	-0.2	4.0	V	
INPUT VOLTAGE	VIN	-0.2	4.0	V	

#### 3.3 ENVIRONMENTAL ABSOLUTE MAXIMUM RATINGS

ITEM	OPERATING		STORAGE		REMARK
	MIN.	MAX.	MIN.	MAX.	
AMBIENT TEMPERATURE	-20°C	70°C	-30°C	80°C	NOTE (1), (2)
HUMIDITY	NOTE (3)		NOTE (3)		WITHOUT CONDENSATION
VIBRATION	—	2.45 m/s <sup>2</sup> (0.25 G)	—	11.76 m/s <sup>2</sup> (1.2 G)	10~100 Hz XYZ DIRECTIONS 1 Hr. EACH
SHOCK	—	29.4 m/s <sup>2</sup> (3 G)	—	490.0 m/s <sup>2</sup> (50 G)	10 ms XYZ DIRECTIONS 1 TIME EACH
CORROSIVE GAS	NOT ACCEPTABLE		NOT ACCEPTABLE		

NOTE (1) : Ta AT -30°C : 48HRS MAX.  
80°C : 168HRS MAX.

NOTE (2) : BACKGROUND COLOR CHANGES SLIGHTLY DEPENDING ON AMBIENT TEMPERATURE  
THIS PHENOMENON IS REVERSIBLE.

NOTE (3) : Ta ≤ 60°C : 90%RH MAX (96HRS MAX.)

Ta > 60°C : ABSOLUTE HUMIDITY MUST BE LOWER THAN THE HUMIDITY OF 90%RH  
AT 60°C. (96HRS MAX.)

#### 4. ELECTRICAL CHARACTERISTICS

##### 4.1 LCD MODULE ELECTRICAL CHARACTERISTICS

Ta = 25 °C

PARAMETER	SYMBOL	CONDITION	MIN.	TYP.	MAX.	UNIT	REMARK
POWER SUPPLY VOLTAGE FOR VCOM	VCC	—	3	3.3	3.6	V	
POWER SUPPLY VOLTAGE FOR LCD	VDD	—	3	3.3	3.6	V	
POWER SUPPLY CURRENT FOR VCOM	ICC	VCC = 3.3V LED B/L = ON	—	510	600	mA	
POWER SUPPLY CURRENT FOR LCD	IDD	VDD = 3.3V	—	8	12	mA	NOTE ( 1 )
LOW LEVEL INPUT VOLTAGE	VIL	—	0	—	0.3*VCC	V	NOTE ( 2 )
HIGH LEVEL INPUT VOLTAGE	VIH	—	0.7*VCC	—	VCC	V	NOTE ( 2 )
FRAME FREQUENCY	fFRAME	—	50	60	72	Hz	
LED LIFE TIME	—	I <sub>LED</sub> =20mA (PER LED)	30K	—	—	hrs	NOTE ( 3 ) NOTE ( 4 )

NOTE ( 1 ) : THE DISPLAY PATTERN IS ALL “WHITE”.

NOTE ( 2 ) : APPLIED TO TERMINALS /RESET, B0~B7, G0~G7, R0~R7, DCLK, HSYNC, VSYNC, ENB.

NOTE ( 3 ) : CONDITIONS; TA=25 °C, CONTINUOUS LIGHTING

NOTE ( 4 ) : DEFINITIONS OF FAILURE

A. LCD LUMINANCE BECOMES HALF OF THE MINIMUM VALUE.

B. LED DOESN'T LIGHT NORMALLY

NOTE ( 5 ) : AMBIENT TEMP. VS. ALLOWABLE FORWARD CURRENT. (PER LED)

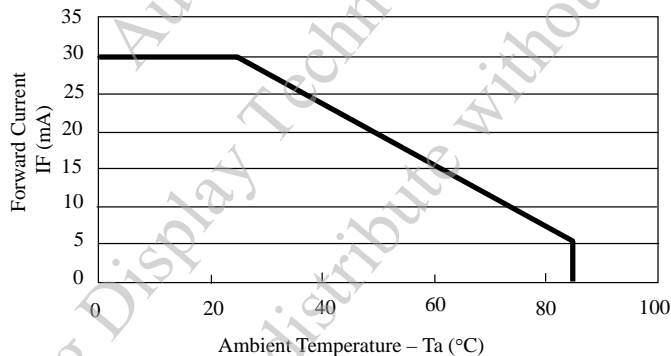

##### 4.2 CAPACITIVE TOUCH PANEL ELECTRICAL CHARACTERISTICS

Ta=25°C

ITEM	SYMBOL	CONDITION	MIN.	TYP.	MAX.	UNIT
POWER SUPPLY FOR DRIVER	VDD1-VSS1	—	2.8	3.3	3.6	V
POWER SUPPLY CURRENT CONSUMPTION FOR OPERATION	IDD1	VDD1=3.3V	—	15	23	mA
INPUT HIGH-LEVEL VOLTAGE	VIH	—	—	0.7VDD1	—	V
INPUT LOW-LEVEL VOLTAGE	VIL	—	—	0.3VDD1	—	V
OUTPUT HIGHT-LEVEL VOLTAGE	VOH	IOH=10mA	VDD1-0.3	—	—	V
OUTPUT LOW-LEVEL VOLTAGE	VOL	IOH=-10mA	—	—	VSS1+0.3	V

## 5. TIMING CHARACTERISTICS

### 5.1 LCD MODULE DIGITAL PARALLEL RGB INTERFACE (SYNC MODE)

ITEM	SYMBOL	MIN.	TYP.	MAX.	UNIT
DCLK FREQUENCY	$F_{CPH}$	22.66	25.175	27.69	MHz
DCLK PERIOD	$T_{CPH}$	36.11	39.7	44.13	ns
DCLK PULSE DUTY	$T_{CWH}$	40	50	60	%
HSYNC PERIOD	$T_H$	750	800	850	$T_{CPH}$
HSYNC PULSE WIDTH	$T_{WH}$	5	30	—	$T_{CPH}$
HSYNC FIRST HORIZONTAL DATA TIME	$T_{HS}$	112	144	175	$T_{CPH}$
HORIZONTAL ACTIVE DATA AREA	$T_{HA}$	—	640	—	$T_{CPH}$
VSYNC PULSE WIDTH	$T_{WV}$	1	3	5	$T_H$
FIRST LINE DATA INPUT TIME	$T_{STV}$	—	35	—	$T_H$
VSYNC PERIOD	$T_V$	515	525	535	$T_H$

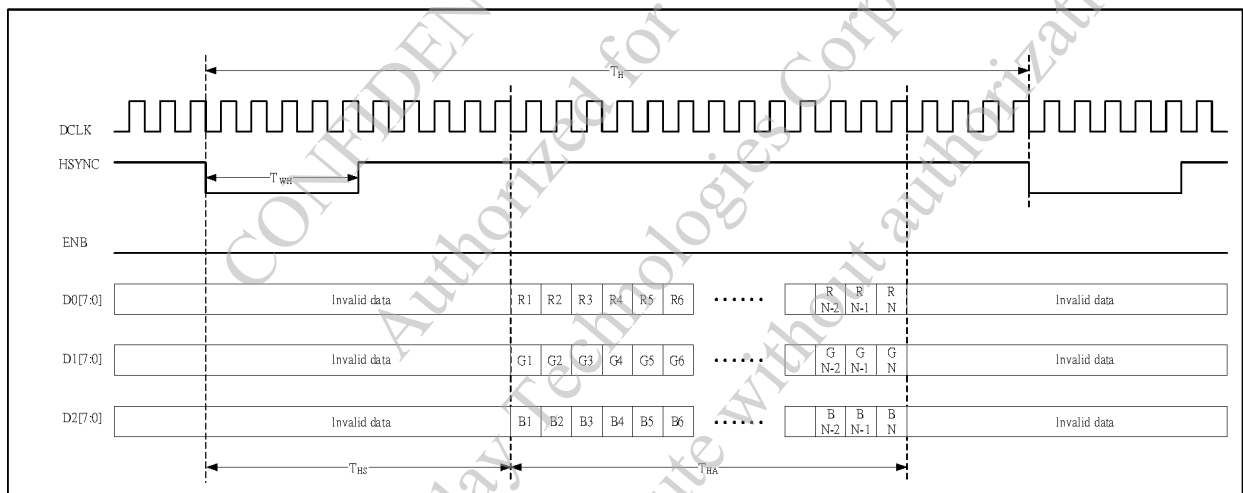

HORIZONTAL TIMING

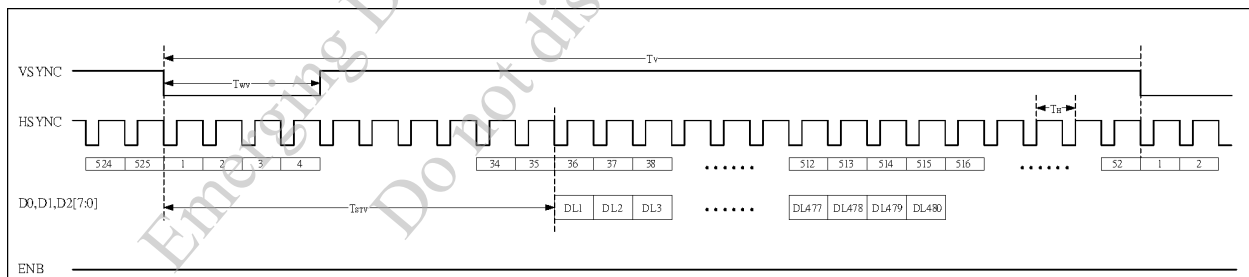

VERTICAL TIMING

5.2 LCD MODULE DIGITAL PARALLEL RGB INTERFACE (DE MODE)

ITEM	SYMBOL	MIN.	TYP.	MAX.	UNIT
DCLK FREQUENCY	$F_{CPH}$	22.66	25.175	27.69	MHz
DCLK PERIOD	$T_{CPH}$	36.11	39.7	44.13	ns
DCLK PULSE DUTY	$T_{CWH}$	40	50	60	%
ENB PERIOD	$T_{DEN}$	750	800	850	$T_{CPH}$
ENB PULSE WIDTH	$T_{EP}$	—	640	—	$T_{CPH}$
ENB FRAME ACTIVE TIME	$T_{DEA}$	—	480	—	$T_H$
ENB FRAME BLANKING TIME	$T_{DEB}$	10	45	110	$T_H$

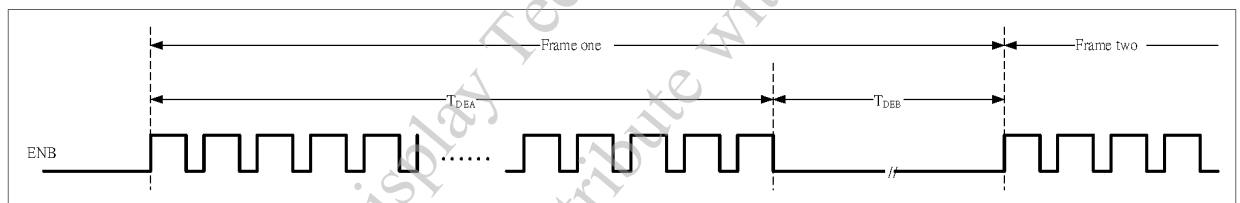
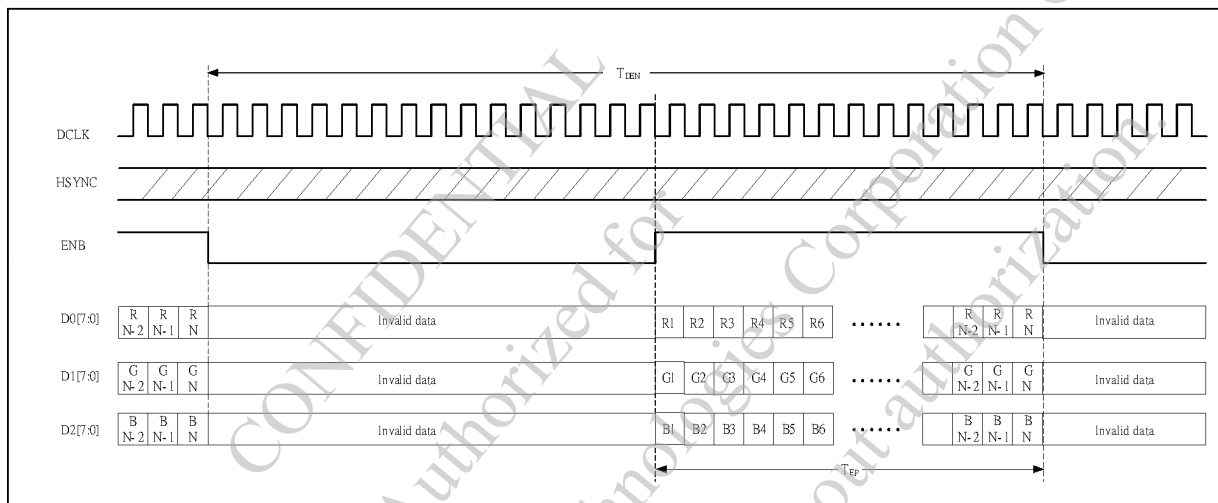

### 5.3 CAPACITIVE TOUCH PANEL MODULE I2C INTERFACE TIMING CHARACTERISTICS

#### 5.3.1 I2C INTERFACE TIMING CHARACTERISTICS

ITEM	MIN.	TYP.	MAX.	UNIT
SCL FREQUENCY	—	—	400	KHz
BUS FREE TIME BETWEEN A STOP AND START CONDITION	1.3	—	—	us
HOLD TIME (REPEATED) START CONDITION	0.6	—	—	us
DATA SETUP TIME	100	—	—	ns
SETUP TIME FOR A REPEATED START CONDITION	0.6	—	—	us
SETUP TIME FOR STOP CONDITION	0.6	—	—	us

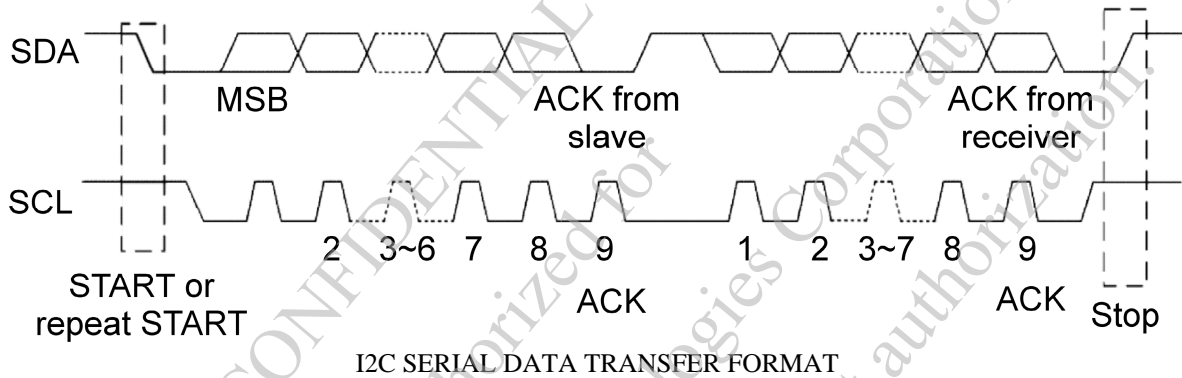

CONFIDENTIAL  
 Authorized for Emerging Display Technologies Corporation Only  
 Do not distribute without authorization

5.3.2 POWER SEQUENCE

ITEM	SYMBOL	MIN.	TYP.	MAX.	UNIT
RISE TIME FROM 0.1VDD TO 0.9VDD	Tris	—	—	5	ms
TIME OF RESETTING TO BE LOW BEFORE POWERING ON	Trtp	100	—	—	us
TIME OF STARTING TO REPORT POINT AFTER POWERING ON	Tpon	200	—	—	ms
RESET TIME AFTER VDD POWERING ON	Tvdr	1	—	—	ms
TIME OF STARTING TO REPORT POINT AFTER RESETTING	Trsi	200	—	—	ms
RESET TIME	Trst	2	—	—	ms

POWER RISE TIMING

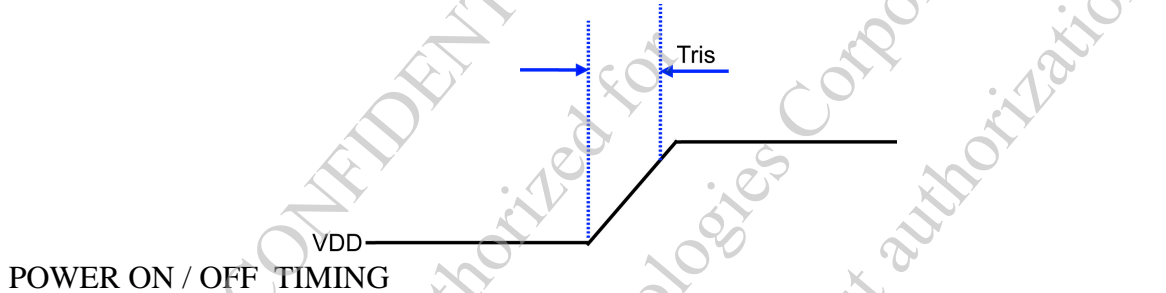

POWER ON / OFF TIMING

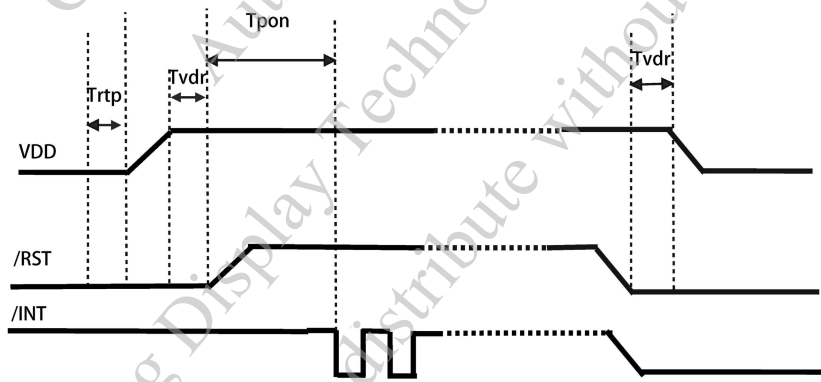

RESET SEQUENCE

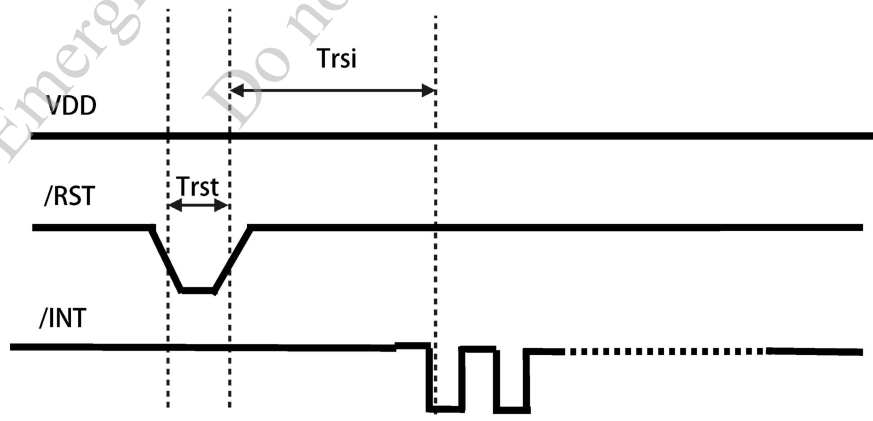

6. OPTICAL CHARACTERISTICS (NOTE 1)

6.1 OPTICAL CHARACTERISTICS

Ta = 25 ± 2 °C

ITEM	SYMBOL	CONDITION	MIN.	TYP.	MAX.	UNIT	REMARK	
VIEWING ANGLE	$\theta_{y+}$	CR ≥ 10	$\theta_x=0^\circ$	50	55	—	deg.	NOTE ( 2 ) NOTE ( 3 )
	$\theta_{y-}$			47	52	—		
	$\theta_{x+}$		$\theta_y=0^\circ$	60	65	—		
	$\theta_{x-}$			60	65	—		
CONTRAST RATIO	CR	$\theta_x=0^\circ, \theta_y=0^\circ$	300	350	—	—	NOTE ( 3 )	
RESPONSE TIME	T <sub>R</sub> ( rise )	$\theta_x=0^\circ, \theta_y=0^\circ$	—	15	30	ms	NOTE ( 4 )	
	T <sub>F</sub> ( fall )		—	35	50			
THE BRIGHTNESS OF MODULE	B	$\theta_x=0^\circ, \theta_y=0^\circ$ IF = 40mA	340	380	—	cd/m <sup>2</sup>	NOTE ( 5 )	
COLOR OF CIE COORDINATE	WHITE	W <sub>x</sub>	$\theta_x=0^\circ, \theta_y=0^\circ$ IF = 40mA NTSC : 50 %	0.26	0.31	0.36	—	NOTE ( 6 )
		W <sub>y</sub>		0.30	0.35	0.40		
	RED	R <sub>x</sub>		0.56	0.61	0.66	—	
		R <sub>y</sub>		0.31	0.36	0.41		
	GREEN	G <sub>x</sub>		0.28	0.33	0.38	—	
		G <sub>y</sub>		0.51	0.56	0.61		
	BLUE	B <sub>x</sub>		0.09	0.14	0.19	—	
		B <sub>y</sub>		0.07	0.12	0.17		
THE UNIFORMITY OF MODULE	—	IF=40mA	75	80	—	%	—	

NOTE ( 1 ) : TEST EQUIPMENT SETUP :

AFTER STABILIZING AND LEAVING THE PANEL ALONE AT A GIVEN TEMPERATURE FOR 30 MINUTES. MEASUREMENT SHOULD BE EXECUTED IN A STABLE, WINDLESS, AND DARK ROOM. OPTICAL SPECIFICATIONS ARE MEASURED BY TOPCON BM-7 (FAST) WITH A VIEWING ANGLE OF 1° AT A DISTANCE OF 50cm AND NORMAL DIRECTION.

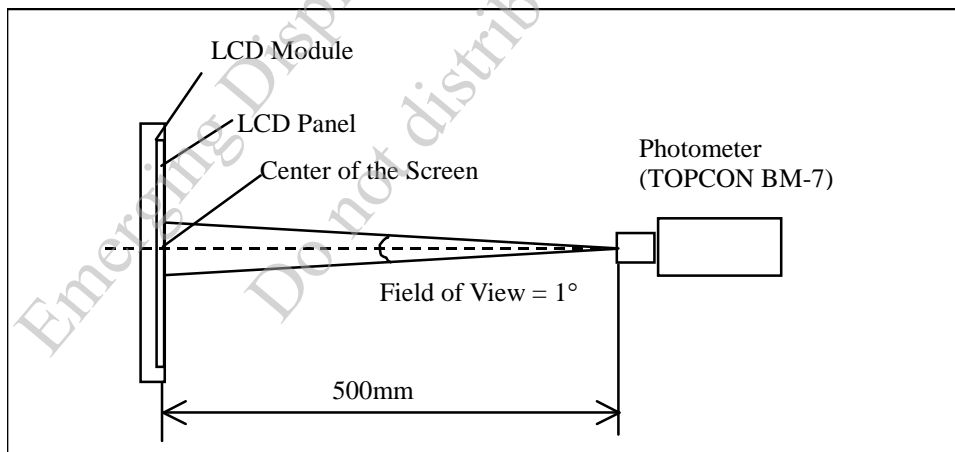

NOTE ( 2 ) : DEFINITION OF VIEWING ANGLE :

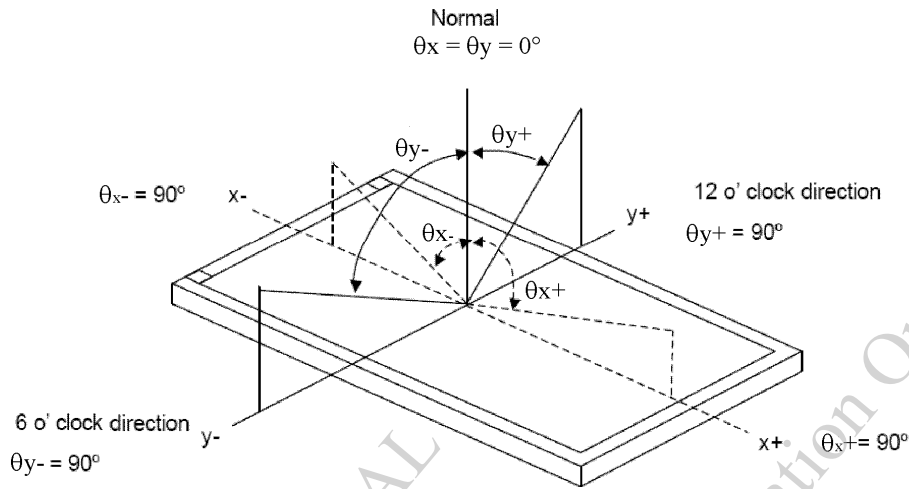

NOTE ( 3 ) : DEFINITION OF CONTRAST RATIO :

$$\text{CONTRAST RATIO(CR)} = \frac{\text{BRIGHTNESS MEASURED WHEN LCD IS AT "WHITE STATE"}}{\text{BRIGHTNESS MEASURED WHEN LCD IS AT "BLACK STATE"}}$$

NOTE ( 4 ) : DEFINITION OF RESPONSE TIME : TR AND TF

THE FIGURE BELOW IS THE OUTPUT SIGNAL OF THE PHOTO DETECTOR.

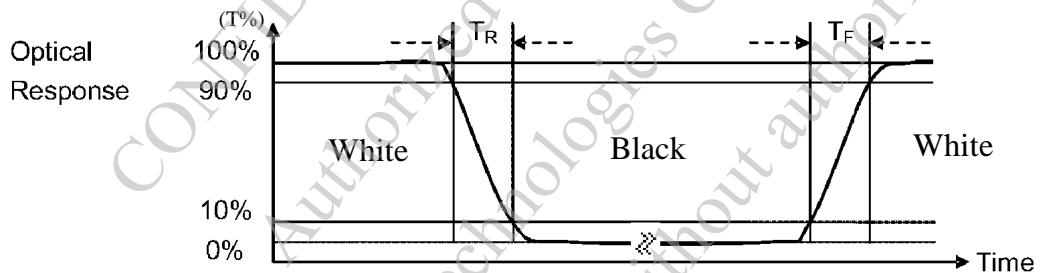

NOTE ( 5 ) : BRIGHTNESS MEASURED WHEN LCD IS AT "WHITE STATE"

NOTE ( 6 ) : THE 100% TRANSMISSION IS DEFINED AS THE TRANSMISSION OF LCD PANEL WHEN ALL THE INPUT TERMINALS OF MODULE ARE ELECTRICALLY OPENED.

### 6.2 THE TEST METHOD OF BRIGHTNESS AND UNIFORMITY

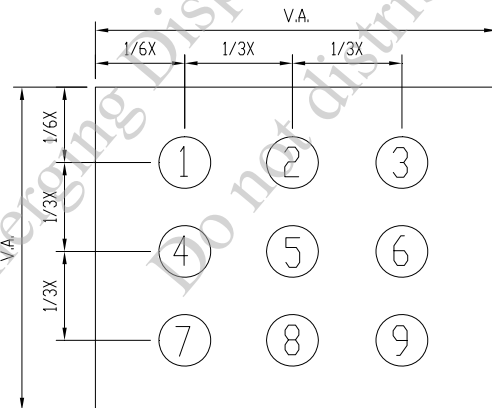

UNIT : mm

### 6.3 THE CALCULATING METHOD OF UNIFORMITY

$$\text{UNIFORMITY} = \left[ 1 - \frac{\text{MAXIMUM BRIGHTNESS} - \text{MINIMUM BRIGHTNESS}}{\text{AVERAGE BRIGHTNESS}} \right] \times 100\%$$

7. OUTLINE DIMENSIONS

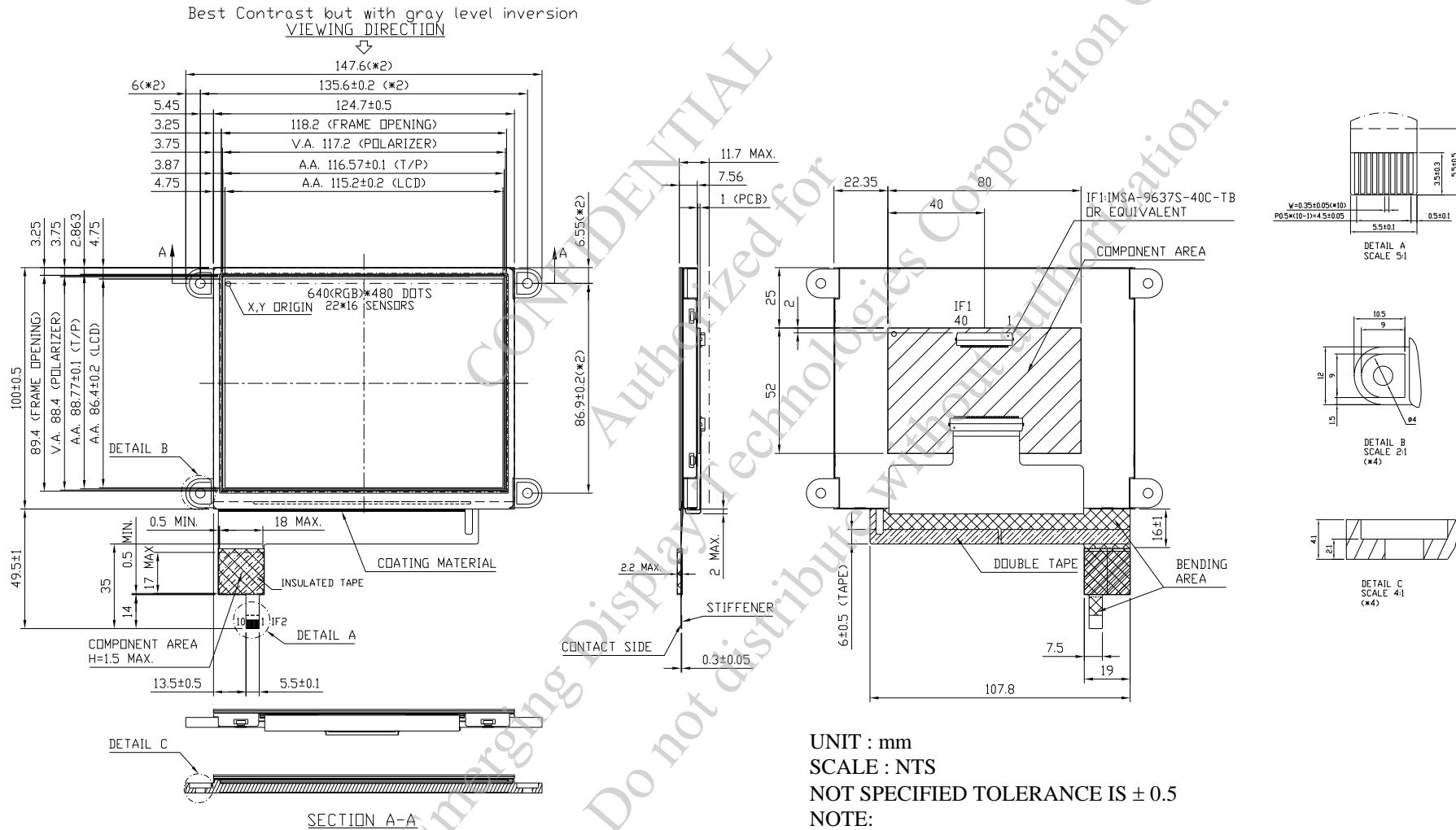

UNIT : mm  
SCALE : NTS  
NOT SPECIFIED TOLERANCE IS ± 0.5  
NOTE:  
1. IF2 RECOMMEND MATCH CONNECTOR KYOCERA:04 6240 010 SERIES

8. BLOCK DIAGRAM

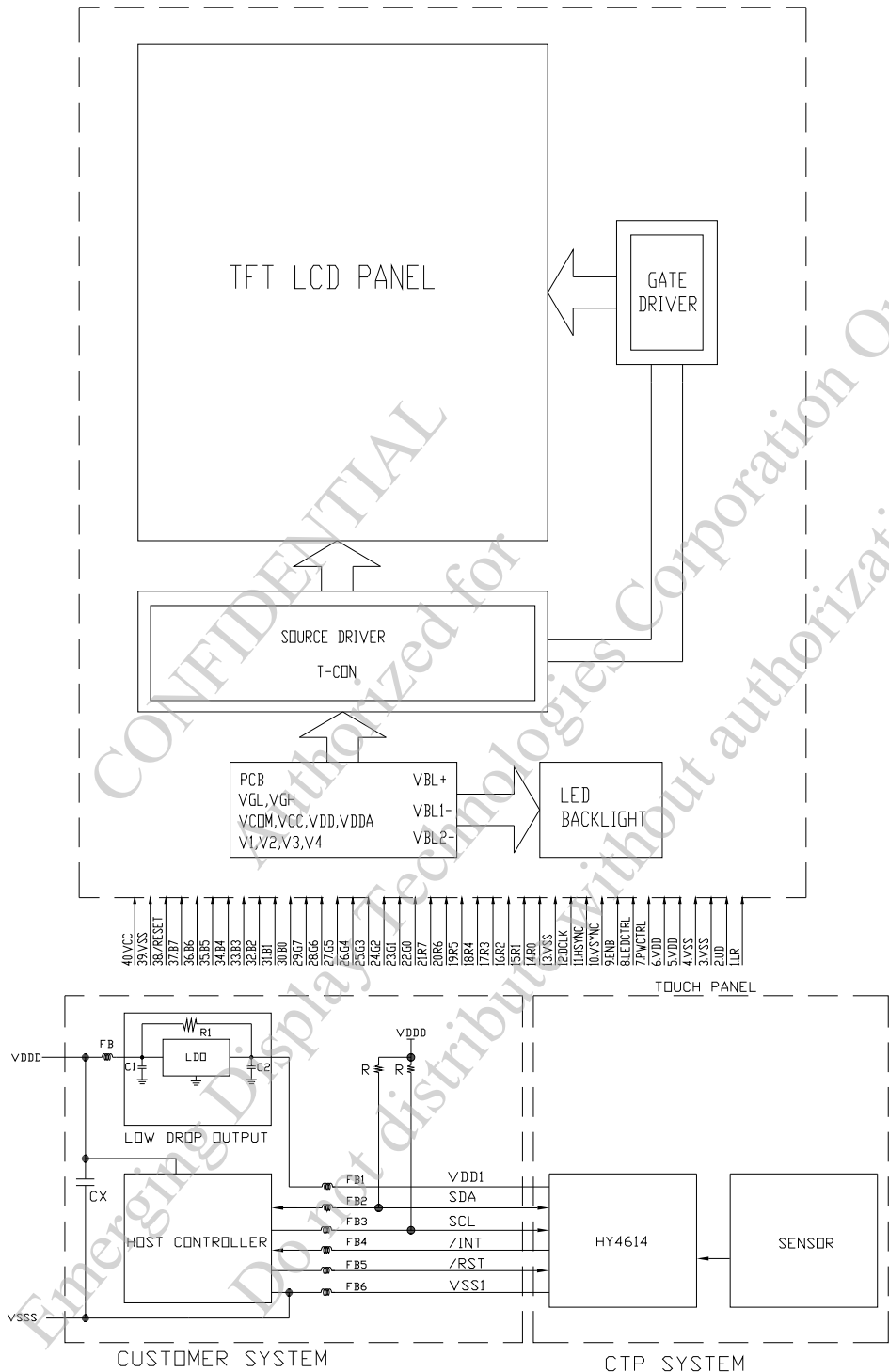

NOTE ( 1 ) : THE STANDARD IIC COMMUNICATION INTERFACE, SUPREME SCL CLOCK IS 400 KHZ, SLAVE ADDRESS CAN BE SET UP, SUPPORTS VDD LEVEL POWER, NEEDS PULL HIGH RESISTANCE AND WE RECOMMEND THE PULL HIGH RESISTANCE IS 2.0K OHM.

NOTE ( 2 ) : POWER SUPPLY SHALL BE CLEAN AND NOISE FREE. ADDITIONAL FILTERING OR A SEPARATE LDO (LOW DROP OUT) REGULATOR CAN BE REQUIRED. C1 AND C2 CAPACITORS RECOMMENDATION : 4.7μF OR 10 μF

9. DETAIL DRAWING OF DOT MATRIX

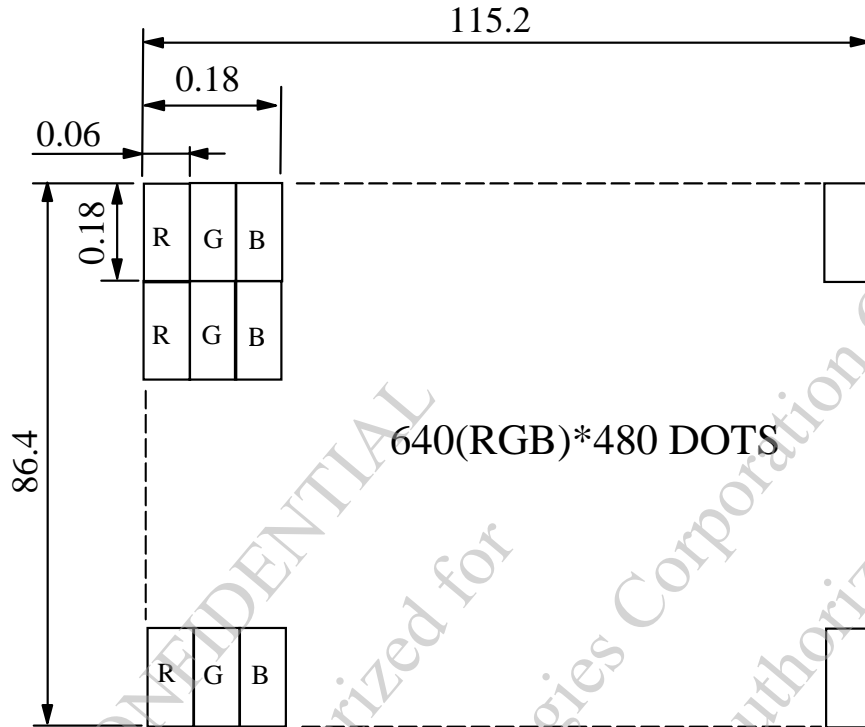

UNIT : mm  
SCALE : NTS  
NOT SPECIFIED TOLERANCE IS  $\pm 0.1$   
DOTS MATRIX TOLERANCE IS  $\pm 0.01$

CONFIDENTIAL  
Authorized for Emerging Display Technologies Corporation Only.  
Do not distribute without authorization.

10. INTERFACE SIGNALS

10.1 CN1 SIGNAL INTERFACES

PIN NO.	SYMBOL	I/O	FUNCTION		
1	LR	I	LR=H:STH→S01→ ---- → S0960 → STHO LR=L:STH→S960→ ---- → S01 → STHO		
2	UD	I	UP/DOWN SCAN SETTING UD=H, REVERSE SCAN UD=L, NORMAL SCAN		
3, 4	VSS	P	GROUND		
5	VDD	P	POWER SUPPLY FOR DIGITAL CIRCUIT		
6	VDD	P	POWER SUPPLY FOR DIGITAL CIRCUIT		
7	PWCTRL	I		PWCTRL	REMARK
				H	POWER ON
			L	SHUTDOWN	
8	LEDCTRL	I	BRIGHTNESS CONTROL FOR LED B/L		
9	ENB	I	DATA ENABLE INPUT	DE MODE & SYNC MODE SETTING DE MODE : ONLY ENB AND PIXEL CLOCK IS NECESSARY. SYNC MODE : ENB SHOULD BE CONNECTED TO VSS. HSYNC/YSYNC AND PIXEL CLOCK IS NECESSARY.	
10	VSYNC	I	VERTICAL SYNC INPUT		
11	HSYNC	I	HORIZONTAL SYNC INPUT		
12	DCLK	I	DOT DATA COLOCK		
13	VSS	P	GROUND		
14	R0	I	RED DATA BIT 0		
15	R1	I	RED DATA BIT 1		
16	R2	I	RED DATA BIT 2		
17	R3	I	RED DATA BIT 3		
18	R4	I	RED DATA BIT 4		
19	R5	I	RED DATA BIT 5		
20	R6	I	RED DATA BIT 6		
21	R7	I	RED DATA BIT 7		
22	G0	I	GREEN DATA BIT 0		
23	G1	I	GREEN DATA BIT 1		
24	G2	I	GREEN DATA BIT 2		
25	G3	I	GREEN DATA BIT 3		
26	G4	I	GREEN DATA BIT 4		
27	G5	I	GREEN DATA BIT 5		
28	G6	I	GREEN DATA BIT 6		
29	G7	I	GREEN DATA BIT 7		
30	B0	I	BLUE DATA BIT 0		

PIN NO.	SYMBOL	I/O	FUNCTION
31	B1	I	BLUE DATA BIT 1
32	B2	I	BLUE DATA BIT 2
33	B3	I	BLUE DATA BIT 3
34	B4	I	BLUE DATA BIT 4
35	B5	I	BLUE DATA BIT 5
36	B6	I	BLUE DATA BIT 6
37	B7	I	BLUE DATA BIT 7
38	/RESET	I	HARDWARE RESET
39	VSS	P	GROUND
40	VCC	P	POWER SUPPLY FOR VCOM DRIVER CIRCUIT

## 10.2 CN2 SIGNAL INTERFACES

PIN NO.	SYMBOL	FUNCTION
1	VSS1	GROUND
2	VDD1	POWER SUPPLY VOLTAGE
3	SCL	I2C CLOCK INPUT
4	NC	NON CONNECTION
5	SDA	I2C DATA INPUT AND OUTPUT
6	NC	NON CONNECTION
7	/RST	EXTERNAL RESET, LOW IS ACTIVE
8	NC	NON CONNECTION
9	/INT	EXTERNAL INTERRUPT TO THE HOST
10	VSS1	GROUND

11. POWER SUPPLY

11.1 POWER SUPPLY FOR LCM

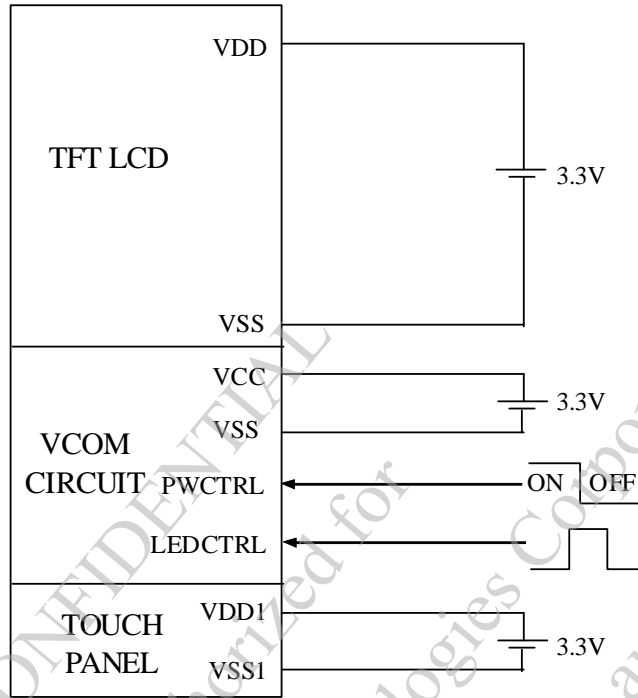

11.2 THE BRIGHTNESS CONTROLLED BY PWM SIGNAL OF LEDCTRL

11.2.1 IF THE DUTY IS BIGGER, THE BRIGHTNESS WILL BE LOWER.

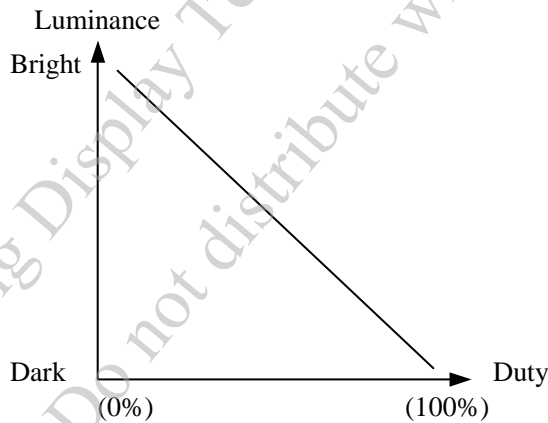

11.2.2 SIGNAL OPERATION FREQUENCY IS 1K ~ 2KHz.

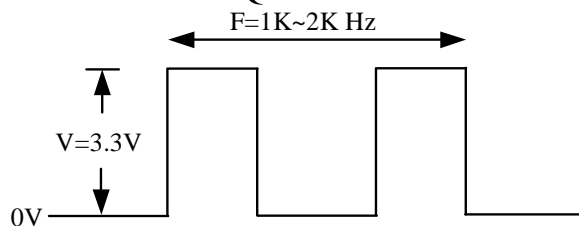

12. CAPACITIVE TOUCH PANEL SPECIFICATION

12.1 OPTICAL CHARACTERISTICS

ITEM	CONDITION	MIN.	TYP.	MAX.	UNIT
TRANSPARENCY NOTE ( 1 )	Ta = 25°C λ=550nm	85	—	—	%

NOTE ( 1 ) : OPTICAL MEASUREMENT SHOULD BE EXECUTED AFTER PANEL IS SECURED.  
MEASUREMENT PROCESS SHOULD BE EXECUTED IN A STABLE, WINDLESS, AND DARK ROOM.  
OPTICAL SPECIFICATIONS SHOULD BE MEASURED BY SPECTROPHOTOMETER.

12.2 HARDNESS

ITEM	DESCRIPTION
SURFACE HARDNESS	7H (MIN.)

12.3 DURABILITY

USING STEEL BALL AND FALLING ON TOUCH PANEL SURFACE, FROM THE HEIGHT MUST PASS BELOW CONDITIONS :

ITEM	CONDITION	INSPECTION METHOD	DESCRIPTION
STEEL BALL DROP TEST	WEIGHT : 67g HEIGHT OF FALL : 30 cm	VISUAL INSPECTION	SIGN OF FRACTURE OR DAMAGE IS NOT ACCEPTABLE 3 TIMES/ 1 POINTS, 25°C(CENTER TEST)

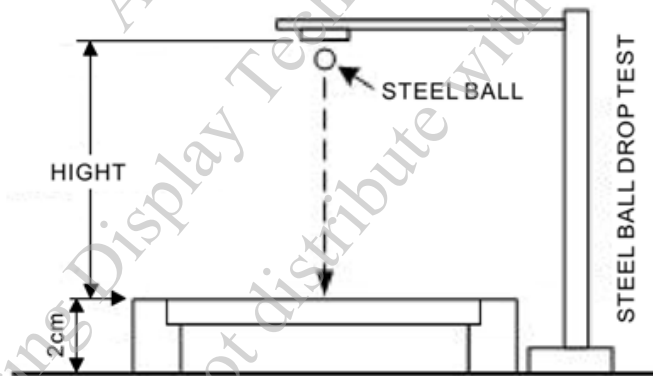

## 12.4 PROTOCOL

### 12.4.1 I2C READ

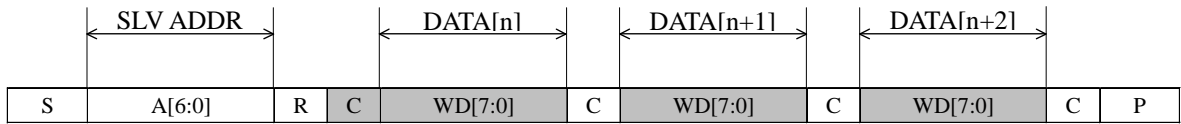

CHARACTER	DESCRIPTION
S	I2C START OR I2C RESTART
A[6:0]	SLAVE ADDRESS, THE VALUE CAN BE CUSTOMIZED
R	OPERATOR BYTE, SHOULD BE 1'b1, STANDS FOR READ
C	ACK SIGNAL
P	STOP SIGNAL (STOP SIGNAL IS OPTIONAL, RESTART SIGNAL IS ALSO OK FOR NEXT PACKET)

SLAVE ADDRESS=0x38

### 12.4.2 INTERRUPT SIGNAL FOR CTPM TO HOST

AS FOR STANDARD CTPM, HOST NEED TO USE BOTH INTERRUPT CONTROL SIGNAL AND SERIAL DATA INTERFACE TO GET THE TOUCH DATA.

HERE IS THE TIMING TO GET TOUCH DATA

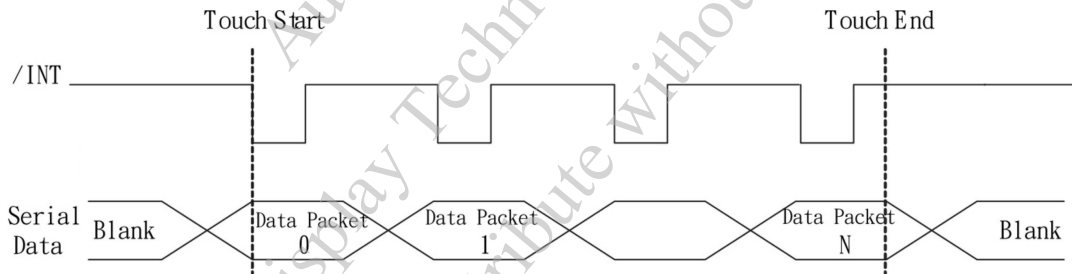

### 12.4.3 READ TOUCH DATA PACKET

WE DEFINED A CTPM PERIOD AS EACH CAPACITANCE DATA GATHERING AND DATA PROCESS, IN EACH CTPM, IF THERE IS A TOUCH DETECTS, THERE WILL WE A FAME OF TOUCH DATA. HOST CAN GET THE SPECIFIED FORMAT TOUCH DATA BY SERIAL DATA INTERFACE.

TOUCH DATA PACKET

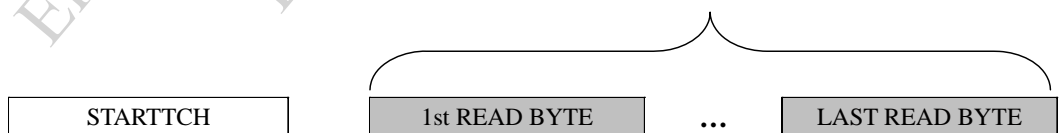

TOUCH DATA FORMAT

TOUCH DATA READ PROTOCOL

IN THIS MODE THE CTP IS FULLY FUNCTIONAL AS A TOUCH SCREEN CONTROLLER. READ AND WRITE ACCESS ADDRESS IS JUST LOGICAL ADDRESS WHICH IS NOT ENFORCED BY HARDWARE OR FIRMWARE. HERE IS THE OPERATING MODE REGISTER MAP.

ADDRESS	NAME	BIT7	BIT6	BIT5	BIT4	BIT3	BIT2	BIT1	BIT0	HOST ACCESS	
02h	TD_STATUS					NUMBER OF TOUCH POINTS[3:0]				R	
03h	TOUCH1_XH	1 <sup>st</sup> EVENT FLAG				1 <sup>st</sup> TOUCH X POSITION[11:8]				R	
04h	TOUCH1_XL	1 <sup>st</sup> TOUCH X POSITION[7:0]									R
05h	TOUCH1_YH	1 <sup>st</sup> TOUCH ID[3:0]				1 <sup>st</sup> TOUCH Y POSITION[11:8]				R	
06h	TOUCH1_YL	1 <sup>st</sup> TOUCH Y POSITION[7:0]									R
07h											
08h											
09h	TOUCH2_XH	2 <sup>nd</sup> EVENT FLAG				2 <sup>nd</sup> TOUCH X POSITION[11:8]				R	
0Ah	TOUCH2_XL	2 <sup>nd</sup> TOUCH X POSITION[7:0]									R
0Bh	TOUCH2_YH	2 <sup>nd</sup> TOUCH ID[3:0]				2 <sup>nd</sup> TOUCH Y POSITION[11:8]				R	
0Ch	TOUCH2_YL	2 <sup>nd</sup> TOUCH Y POSITION[7:0]									R
0Dh											R
0Eh											R
0Fh	TOUCH3_XH	3 <sup>rd</sup> EVENT FLAG				3 <sup>rd</sup> TOUCH X POSITION[11:8]				R	
10h	TOUCH3_XL	3 <sup>rd</sup> TOUCH X POSITION[7:0]									R
11h	TOUCH3_YH	3 <sup>rd</sup> TOUCH ID[3:0]				3 <sup>rd</sup> TOUCH Y POSITION[11:8]				R	
12h	TOUCH3_YL	3 <sup>rd</sup> TOUCH Y POSITION[7:0]									R
13h											R
14h											R
15h	TOUCH4_XH	4 <sup>th</sup> EVENT FLAG				4 <sup>th</sup> TOUCH X POSITION[11:8]				R	
16h	TOUCH4_XL	4 <sup>th</sup> TOUCH X POSITION[7:0]									R
17h	TOUCH4_YH	4 <sup>th</sup> TOUCH ID[3:0]				4 <sup>th</sup> TOUCH Y POSITION[11:8]				R	
18h	TOUCH4_YL	4 <sup>th</sup> TOUCH Y POSITION[7:0]									R
19h											R
1Ah											R
1Bh	TOUCH5_XH	5 <sup>th</sup> EVENT FLAG				5 <sup>th</sup> TOUCH X POSITION[11:8]				R	
1Ch	TOUCH5_XL	5 <sup>th</sup> TOUCH X POSITION[7:0]									R
1Dh	TOUCH5_YH	5 <sup>th</sup> TOUCH ID[3:0]				5 <sup>th</sup> TOUCH Y POSITION[11:8]				R	
1Eh	TOUCH5_YL	5 <sup>th</sup> TOUCH Y POSITION[7:0]									R
1Fh											R
20h											R
A6h	ID_G_FIRMID	FIRMWARE ID								R	

**TD\_STATUS**

THIS REGISTER IS THE TOUCH DATA STATUS REGISTER.

ADDRESS	BIT ADDRESS	REGISTER NAME	DESCRIPTION
02h	3:0	NUMBER OF TOUCH POINTS [3:0]	HOW MANY POINTS DETECTED. 1-5 IS VALID.
	7:4	NONE	NONE

**TOUCH<sub>n</sub>\_XH (n:1-5)**

THIS REGISTER DESCRIBES MSB OF THE X COORDINATE OF THE NTH TOUCH POINT AND THE CORRESPONDING EVENT FLAG.

ADDRESS	BIT ADDRESS	REGISTER NAME	DESCRIPTION
03h ~ 1Bh	7:6	EVENT FLAG	00b: PUT DOWN 01b: PUT UP 10b: CONTACT 11b: RESERVED
	5:4	NONE	RESERVED
	3:0	TOUCH X POSITION [11:8]	MSB OF TOUCH X POSITION IN PIXELS

**TOUCH<sub>n</sub>\_XL (n:1-5)**

THIS REGISTER DESCRIBES LSB OF THE X COORDINATE OF THE NTH TOUCH POINT.

ADDRESS	BIT ADDRESS	REGISTER NAME	DESCRIPTION
04h ~ 1Ch	7:0	TOUCH X POSITION [7:0]	LSB OF THE TOUCH X POSITION IN PIXELS

**TOUCH<sub>n</sub>\_YH (n:1-5)**

THIS REGISTER DESCRIBES MSB OF THE Y COORDINATE OF THE NTH TOUCH POINT AND CORRESPONDING TOUCH ID.

ADDRESS	BIT ADDRESS	REGISTER NAME	DESCRIPTION
05h ~ 1Dh	7:4	TOUCH ID [3:0]	TOUCH ID OF TOUCH POINT
	3:0	TOUCH X POSITION [11:8]	MSB OF TOUCH Y POSITION IN PIXELS

**TOUCH<sub>n</sub>\_YL (n:1-5)**

THIS REGISTER DESCRIBES LSB OF THE Y COORDINATE OF THE NTH TOUCH POINT.

ADDRESS	BIT ADDRESS	REGISTER NAME	DESCRIPTION
06h ~ 1Eh	7:0	TOUCH X POSITION [7:0]	LSB OF THE TOUCH Y POSITION IN PIXELS

**ID\_G\_FIRMWARE\_ID**

THIS REGISTER DESCRIBES THE FIRMWARE ID OF THE APPLICATION

ADDRESS	BIT ADDRESS	REGISTER NAME	DESCRIPTION
A6h	7:0	ID_G_FIRMWARE_ID	FIRMWARE VERSION

12.5 INSPECTION STANDARDS

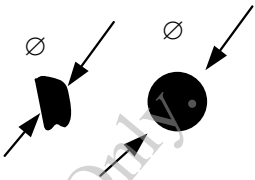
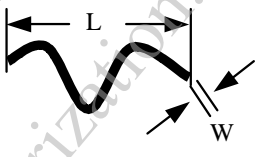
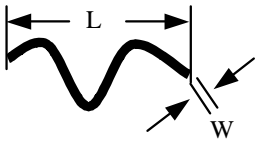
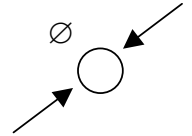
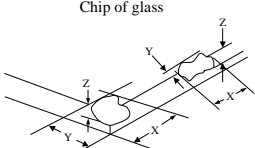
INSPECTION ITEMS	CRITERIA	REMARK	
BLACK/WHITE SPOT	THE FOLLOWING BLACK/WHITE SPOT ARE WITHIN THE VIEWING AREA. AVERAGE DIAMETER : D (mm)		
	SIZE D		PERMISSIBLE NO.
	D ≤ 0.1mm		IGNORE
	0.1mm < D ≤ 0.3mm		5
	0.3mm < D ≤ 0.5mm		5
D > 0.5 mm	0		
	NOTE ( 1 ) : THE DISTANCE BETWEEN DEFECTS SHOULD BE MORE THAN 10mm APART.		
SCRATCH	THE FOLLOWING BLACK LINE, WHITE LINE IS WITHIN THE VIEWING AREA. WIDTH : W (mm) , LENGH : L (mm)		
	SIZE W & L		PERMISSIBLE NO.
	W ≤ 0.05mm		IGNORE
	0.05mm < W ≤ 0.07mm, L ≤ 5mm		1
W > 0.07mm	0		
LINEAR TYPE / FOREIGN FIBER	THE FOLLOWING BLACK LINE, WHITE LINE IS WITHIN THE VIEWING AREA. WIDTH : W (mm) , LENGH : L (mm)		
	SIZE W & L		PERMISSIBLE NO.
	W ≤ 0.05mm		IGNORE
	0.05mm < W ≤ 0.07mm, L ≤ 5mm		1
W > 0.07mm	0		
BUBBLE / DENT	BUBBLES WITHIN VIEWING AREA. AVERAGE DIAMETER : D (mm)		
	SIZE D		PERMISSIBLE NO.
	W ≤ 0.2mm		IGNORE
	0.2mm < W ≤ 0.3mm		3
	0.3mm < W ≤ 0.5mm		1
W > 0.5mm	0		
	NOTE ( 1 ) : THE DISTANCE BETWEEN DEFECTS SHOULD BE MORE THAN 10mm APART.		
CHIP DAMAGE ON GLASS	CORNER	X ≤ 3mm 、 Y ≤ 3mm 、 Z ≤ t (t : THICKNESS)	
	EDGE	X ≤ 6mm , Y ≤ 1mm , Z ≤ t (t : THICKNESS)	

NOTE :

- 1.FOR ANY SPOTS OR LINES, WHICH ARE NOT OBSERVED UNDER APPROPRIATE PANEL OPERATING CONDITION ARE DEEMED ACCEPTABLE.
- 2.THE FOREIGN MATERIALS THAT CAN BE BLOWN OUT BY AIR AND REMOVED BY WET CLEANING ARE NOT REGARDED AS DEFECTS.

13. INSPECTION CRITERION

13.1 APPLICATION

THIS INSPECTION STANDARD IS TO BE APPLIED TO THE LCD MODULE DELIVERED FROM EMERGING DISPLAY TECHNOLOGIES CORP.( E.D.T ) TO CUSTOMERS

13.2 INSPECTION CONDITIONS

13.2.1 (1)OBSERVATION DISTANCE : 35±5cm

(2)VIEW ANGLE :

NON-OPERATION CONDITION : ±5°  
(PERPENDICULAR TO LCD PANEL SURFACE)

OPERATION CONDITION : ±45°  
(PERPENDICULAR TO LCD PANEL SURFACE)

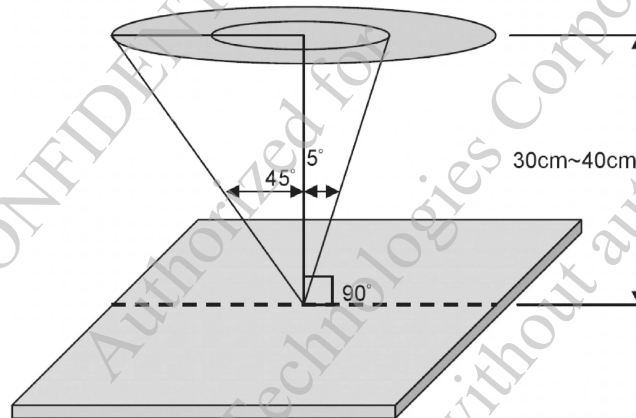

13.2.2 ENVIRONMENT CONDITIONS :

AMBIENT TEMPERATURE		25±5°C
AMBIENT HUMIDITY		65±20%RH
AMBIENT ILLUMINATION	COSMETIC INSPECTION	600~800 Lux
	FUNCTIONAL INSPECTION	300~500 Lux

13.2.3 INSPECTION LOT

QUANTITY PER DELIVERY LOT FOR EACH MODEL

13.2.4 INSPECTION METHOD

A SAMPLING INSPECTION SHALL BE MADE ACCORDING TO THE FOLLOWING PROVISIONS TO JUDGE THE ACCEPTABILITY

(a)APPLICABLE STANDARD : MIL-STD-105E

NORMAL INSPECTION, SINGLE SAMPLING LEVEL II

(b)AQL : MAJOR DEFECT : AQL 0.65

MINOR DEFECT : AQL 1.0

13.3 INSPECTION STANDARDS

13.3.1 VISUAL DEFECTS CLASSIFICATION

TYPE OF DEFECT	INSPECTION ITEM	DEFECT FEATURE	AQL
MAJOR DEFECT	1.DISPLAY ON	<ul style="list-style-type: none"> <li>• DEFECT TO MISS SPECIFIED DISPLAY FUNCTION, FOR ALL AND SPECIFIED DOTS</li> <li>EX: DISCONNECTION, SHORT CIRCUIT ETC</li> </ul>	0.65
	2.BACKLIGHT	<ul style="list-style-type: none"> <li>• NO LIGHT</li> <li>• FLICKERING AND OTHER ABNORMAL ILLUMINATION</li> </ul>	
	3.DIMENSIONS	<ul style="list-style-type: none"> <li>• SUBJECT TO INDIVIDUAL ACCEPTANCE SPECIFICATIONS</li> </ul>	
MINOR DEFECT	1.DISPLAY ZONE	<ul style="list-style-type: none"> <li>• BLACK/WHITE SPOT</li> <li>• BUBBLES ON POLARIZER</li> <li>• NEWTON RING</li> <li>• BLACK/WHITE LINE</li> <li>• SCRATCH</li> <li>• CONTAMINATION</li> <li>• LEVER COLOR SPREED</li> </ul>	1.0
	2.BEZEL ZONE	<ul style="list-style-type: none"> <li>• STAINS</li> <li>• SCRATCHES</li> <li>• FOREIGN MATTER</li> </ul>	
	3.SOLDERING	<ul style="list-style-type: none"> <li>• INSUFFICIENT SOLDER</li> <li>• SOLDERED IN INCORRECT POSITION</li> <li>• CONVEX SOLDERING SPOT</li> <li>• SOLDER BALLS</li> <li>• SOLDER SCRAPS</li> </ul>	
	4.DISPLAY ON (ALL ON)	<ul style="list-style-type: none"> <li>• LIGHT LINE</li> </ul>	

13.3.2 MODULE DEFECTS CALSSIFICATION

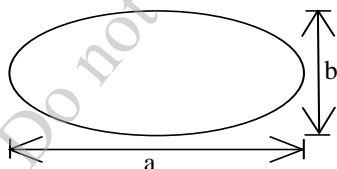
NO.	ITEM	CRITERIA												
1	DISPLAY ON INSPECTION	(1)INCORRECT PATTERN (2)MISSING SEGMENT (3)DIM SEGMENT (4)OPERATING VOLTAGE BEYOND SPEC												
2	OVERALL DIMENSIONS	(1)OVERALL DIMENSION BEYOND SPEC												
3	DOT DEFECT	(1)INSPECTION PATTERN: FULL WHITE, FULL BLACK, RED, GREEN AND BLUE SCREENS. (2) <table border="1" style="margin-left: 20px;"> <thead> <tr> <th>ITEMS</th> <th>ACCEPTABLE COUNT</th> </tr> </thead> <tbody> <tr> <td>BRIGHT DOT</td> <td><math>N \leq 2</math></td> </tr> <tr> <td>ARK DOT</td> <td><math>N \leq 3</math></td> </tr> <tr> <td>OAL BRIGHT AND DARK DOTS</td> <td><math>N \leq 4</math></td> </tr> </tbody> </table> <p>NOTE : 1. THE DEFINITION OF DOT : THE SIZE OF A DEFECTIVE DOT OVER 1/2 OF WHOLE DOT IS REGARDED AS ONE DEFECTUVE DOT. 2. BRIGHT DOT : DOTS APPEAR BRIGHT AND UNCHANGED IN SIZE IN WHICH LCD PANEL IS DISPLAYING UNDER BLACK PATTERN. 3. DARK DOT : DOTS APPEAR DARK AND UNCHANGED IN SIZE IN WHICH LCD PANEL IS DISPLAYING UNDER PURE RED, GREEN, BLUE PICTURE.</p>	ITEMS	ACCEPTABLE COUNT	BRIGHT DOT	$N \leq 2$	ARK DOT	$N \leq 3$	OAL BRIGHT AND DARK DOTS	$N \leq 4$				
ITEMS	ACCEPTABLE COUNT													
BRIGHT DOT	$N \leq 2$													
ARK DOT	$N \leq 3$													
OAL BRIGHT AND DARK DOTS	$N \leq 4$													
4	FOREIGN BLACK/WHITE/ BRIGHT LINE/ SCRATCH OF VIEWING AREA	<table border="1" style="margin-left: 20px;"> <thead> <tr> <th>LENGTH : L</th> <th>WIDTH : W</th> <th>PERMISSIBLE NO.</th> </tr> </thead> <tbody> <tr> <td><math>L \leq 0.3</math></td> <td><math>W \leq 0.05</math></td> <td>IGNORE</td> </tr> <tr> <td><math>0.3 &lt; L \leq 2.5</math></td> <td><math>0.05 &lt; W \leq 0.1</math></td> <td>4</td> </tr> <tr> <td><math>2.5 &lt; L</math></td> <td><math>0.1 &lt; W</math></td> <td>NONE</td> </tr> </tbody> </table> <p>WIDTH : W mm, LENGH : L mm</p>	LENGTH : L	WIDTH : W	PERMISSIBLE NO.	$L \leq 0.3$	$W \leq 0.05$	IGNORE	$0.3 < L \leq 2.5$	$0.05 < W \leq 0.1$	4	$2.5 < L$	$0.1 < W$	NONE
LENGTH : L	WIDTH : W	PERMISSIBLE NO.												
$L \leq 0.3$	$W \leq 0.05$	IGNORE												
$0.3 < L \leq 2.5$	$0.05 < W \leq 0.1$	4												
$2.5 < L$	$0.1 < W$	NONE												
5	FOREIGN MATTER \ BLACK SPOTS \ WHITE SPOTS \ DENT (INCLUDING LIGHT LEAKAGE DUE TO POLARIZING PLATES PINHOLES, ETC.)	<table border="1" style="margin-left: 20px;"> <thead> <tr> <th>AVERAGE DIAMETER (mm): D</th> <th>NUMBER OF PIECES PERMITTED</th> </tr> </thead> <tbody> <tr> <td><math>D \leq 0.15</math></td> <td>IGNORE</td> </tr> <tr> <td><math>0.15 &lt; D \leq 0.5</math></td> <td>4</td> </tr> <tr> <td><math>0.5 &lt; D</math></td> <td>NONE</td> </tr> </tbody> </table> <p>NOTE : DIAMETER <math>D=(a+b)/2</math></p> 	AVERAGE DIAMETER (mm): D	NUMBER OF PIECES PERMITTED	$D \leq 0.15$	IGNORE	$0.15 < D \leq 0.5$	4	$0.5 < D$	NONE				
AVERAGE DIAMETER (mm): D	NUMBER OF PIECES PERMITTED													
$D \leq 0.15$	IGNORE													
$0.15 < D \leq 0.5$	4													
$0.5 < D$	NONE													

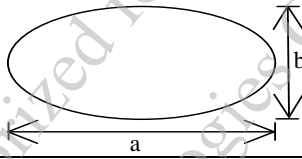
NO.	ITEM	CRITERIA		
			AVERAGE DIAMETER (mm) : D	NUMBER OF PIECES PERMITTED
6	BUBBLES OF POLARIZER /DIRT/CF FAIL /SURFACE STAINS	BUBBLE ON THE POLARIZER	$D \leq 0.25$	IGNORE
			$0.25 < D \leq 0.5$	$N \leq 5$
			$0.5 < D$	NONE
		SURFACE STAINS	$D < 0.1$	IGNORE
			$0.1 < D \leq 0.3$	$N \leq 3$
		CF FAIL / SPOT	$D < 0.1$	IGNORE
$0.1 < D \leq 0.3$	$N \leq 3$			
		<p>NOTE : (1)POLARIZER BUBBLE IS DEFINED AS THE BUBBLE APPEARS ON ACTIVE DISPLAY AREA. THE DEFECT OF POLARIZER BUBBLE SHALL BE IGNORED IF THE POLARIZER BUBBLE APPEARS ON THE OUTSIDE OF ACTIVE DISPLAY AREA.</p> <p>(2)THE EXTRANEIOUS SUBSTANCE IS DEFINED AS IT CAN BE OBSERVED WHEN THE MODULE IS POWER ON.</p> <p>(3)THE DEFINITION OF AVERAGE DIAMETER, D IS DEFINED AS FOLLOWING.</p> <p>AVERAGE DIAMETER (D)=(a+b)/2</p> 		
7	LINE DEFECT ON DISPLAY	OBVIOUS VERTICAL OR HORIZONTAL LINE DEFECT IS NOT ALLOWED		
8	MURA ON DISPLAY	IT'S OK IF MURA IS SLIGHT VISIBLE THROUGH 6% ND FILTER		
9	UNEVEN COLOR SPREAD, COLORATION	(1)TO BE DETERMINED BASED UPON THE STANDARD SAMPLE.		
10	BEZEL APPEARANCE	(1)BEZEL MAY NOT HAVE RUST, BE DEFORMED OR HAVE FINGER PRINTS STAINS OF OTHER CONTAMINATION. (2)BEZEL MUST COMPLY WITH JOB SPECIFICATIONS.		
11	PCB	<p>(1)THERE MAY NOT BE MORE THAN 2mm OF SEALANT OUTSIDE THE SEAL AREA ON THE PCB, AND THERE SHOULD BE NO MORE THAN THREE PLACES.</p> <p>(2)NO OXIDATION OR CONTAMINATION PCB TERMINALS.</p> <p>(3)PARTS ON PCB MUST BE THE SAME AS ON THE PRODUCTION CHARACTERISTIC CHART. THERE SHOULD BE NO WRONG PARTS, MISSING PARTS OR EXCESS PARTS.</p> <p>(4)THE JUMPER ON THE PCB SHOULD CONFORM TO THE PRODUCT CHARACTERISTIC CHART.</p> <p>(5)IF SOLDER GETS ON BEZEL TAB PADS, LED PAD, ZEBRA PAD OR SCREW HOLD PAD; MAKE SURE IT IS SMOOTHED DOWN.</p>		

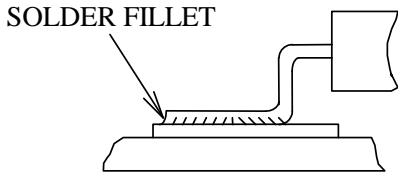
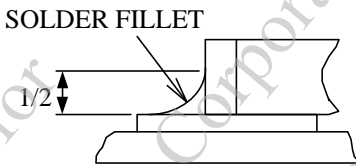
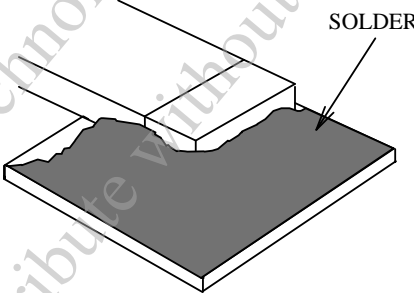
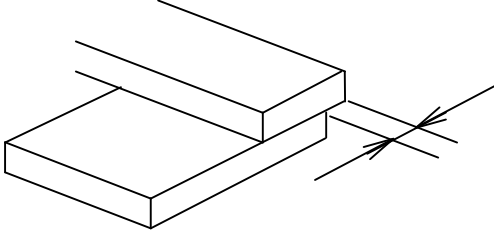
NO.	ITEM	CRITERIA
12	SOLDERING	<p>(1)NO SOLDERING FOUND ON THE SPECIFIED PLACE (2)INSUFFICIENT SOLDER</p> <p>(a)LSI, IC A POOR WETTING OF SOLDER IS BETWEEN LOWER BEND OR "HEEL" OF LEAD AND PAD</p>  <p>(b)CHIP COMPONENT · SOLDER IS LESS THAN 50% OF SIDES AND FRONT FACE WETTING</p>  <p>· SOLDER WETS 3 SIDES OF TERMINAL, BUT LESS THAN 25% OF SIDES AND FRONT SURFACE AREA ARE COVERED</p>  <p>(3)PARTS ALIGMENT (a)LSI, IC LEAD WIDTH IS MORE THAN 50% BEYOND PAD OUTLINE</p> 

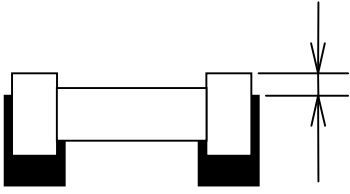
NO.	ITEM	CRITERIA
12	SOLDERING	<p>(b)CHIP COMPONENT COMPONENT IS OFF CENTER, AND MORE THAN 50% OF THE LEADS IS OFF THE PAD OUTLINE</p>  <p>(4)NO UNMELTED SOLDER PASTE MAY BE PRESENT ON THE PCB.            (5)NO COLD SOLDER JOINTS, MISSING SOLDER CONNECTIONS, OXIDATION OR ICICLE.            (6)NO RESIDUE OR SOLDER BALLS ON PCB.            (7)NO SHORT CIRCUITS IN COMPONENTS ON PCB.</p>
13	BACKLIGHT	<p>(1)NO LIGHT            (2)FLICKERING AND OTHER ABNORMAL ILLUMINATION            (3)SPOTS OR SCRATCHES THAT APPEAR WHEN LIT MUST BE JUDGED USING LCD SPOT, LINES AND CONTAMINATION STANDARDS.            (4)BACKLIGHT DOESN'T LIGHT OR COLOR IS WRONG.</p>
14	GENERAL APPEARANCE	<p>(1)NO OXIDATION, CONTAMINATION, CURVES OR, BENDS ON INTERFACE PIN (OLB) OF TCP.            (2)NO CRACKS ON INTERFACE PIN (OLB) OF TCP.            (3)NO CONTAMINATION, SOLDER RESIDUE OR SOLDER BALLS ON PRODUCT.            (4)THE IC ON THE TCP MAY NOT BE DAMAGED, CIRCUITS.            (5)THE UPPERMOST EDGE OF THE PROTECTIVE STRIP ON THE INTERFACE PIN MUST BE PRESENT OR LOOK AS IF IT CAUSE THE INTERFACE PIN TO SEVER.            (6)THE RESIDUAL ROSIN OR TIN OIL OF SOLDERING (COMPONENT OR CHIP COMPONENT) IS NOT BURNED INTO BROWN OR BLACK COLOR.            (7)SEALANT ON TOP OF THE ITO CIRCUIT HAS NOT HARDENED.            (8)PIN TYPE MUST MATCH TYPE IN SPECIFICATION SHEET.            (9)LCD PIN LOOSE OR MISSING PINS.            (10)PRODUCT PACKAGING MUST THE SAME AS SPECIFIED ON PACKAGING SPECIFICATION SHEET.            (11)PRODUCT DIMENSION AND STRUCTURE MUST CONFORM TO PRODUCT SPECIFICATION SHEET.            (12)THE APPEARANCE OF HEAT SEAL SHOULD NOT ADMIT ANY DIRT AND BREAK.</p>

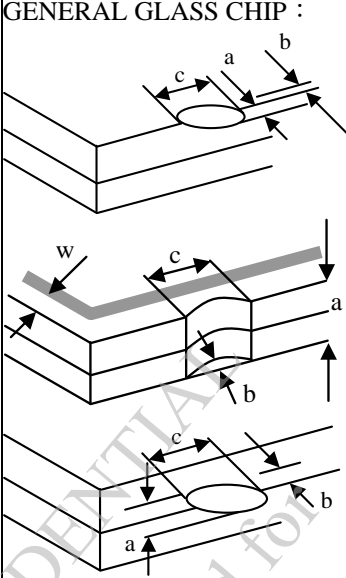
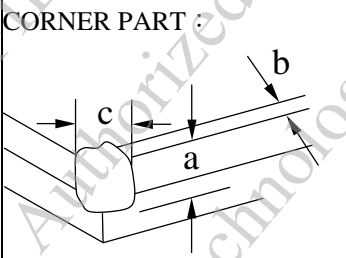
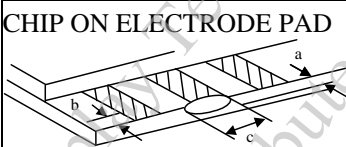
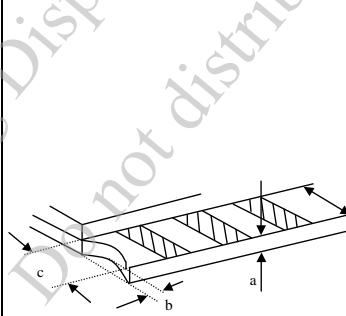
NO.	ITEM	CRITERIA									
15	CRACKED GLASS	<p>THE LCD WITH EXTENSIVE CRACK IS NOT ACCEPTABLE</p> <p>GENERAL GLASS CHIP :</p>  <table border="1"> <thead> <tr> <th>a</th> <th>b</th> <th>c</th> </tr> </thead> <tbody> <tr> <td><math>\leq t/2</math></td> <td>&lt; VIEWING AREA</td> <td><math>\leq 1/8X</math></td> </tr> <tr> <td><math>t/2 &gt; , \leq 2t</math></td> <td><math>\leq W/2</math></td> <td><math>\leq 1/8X</math></td> </tr> </tbody> </table> <p>*W=DISTANCE BETWEEN SEALANT AREA AND LCD PANEL EDGE X = LCD SIDE LENGTH t = GLASS THICKNESS</p>	a	b	c	$\leq t/2$	< VIEWING AREA	$\leq 1/8X$	$t/2 > , \leq 2t$	$\leq W/2$	$\leq 1/8X$
		a	b	c							
		$\leq t/2$	< VIEWING AREA	$\leq 1/8X$							
		$t/2 > , \leq 2t$	$\leq W/2$	$\leq 1/8X$							
<p>CORNER PART :</p>  <table border="1"> <thead> <tr> <th>a</th> <th>b</th> <th>c</th> </tr> </thead> <tbody> <tr> <td><math>\leq t/2</math></td> <td>&lt; VIEWING AREA</td> <td><math>\leq 1/8X</math></td> </tr> <tr> <td><math>&gt; t/2 , \leq 2t</math></td> <td><math>\leq W/2</math></td> <td><math>\leq 1/8X</math></td> </tr> </tbody> </table> <p>*W=DISTANCE BETWEEN SEALANT AREA AND LCD PANEL EDGE X = LCD SIDE LENGTH t = GLASS THICKNESS</p>	a	b	c	$\leq t/2$	< VIEWING AREA	$\leq 1/8X$	$> t/2 , \leq 2t$	$\leq W/2$	$\leq 1/8X$		
a	b	c									
$\leq t/2$	< VIEWING AREA	$\leq 1/8X$									
$> t/2 , \leq 2t$	$\leq W/2$	$\leq 1/8X$									
<p>CHIP ON ELECTRODE PAD</p>  <table border="1"> <thead> <tr> <th>a</th> <th>b</th> <th>c</th> </tr> </thead> <tbody> <tr> <td><math>\leq t</math></td> <td><math>\leq 0.5\text{mm}</math></td> <td><math>\leq 1/8X</math></td> </tr> </tbody> </table> <p>* X=LCD SIDE WIDTH t=GLASS THICKNESS</p>	a	b	c	$\leq t$	$\leq 0.5\text{mm}$	$\leq 1/8X$					
a	b	c									
$\leq t$	$\leq 0.5\text{mm}$	$\leq 1/8X$									
 <table border="1"> <thead> <tr> <th>a</th> <th>b</th> <th>c</th> </tr> </thead> <tbody> <tr> <td><math>\leq t</math></td> <td><math>\leq 1/8X</math></td> <td><math>\leq L</math></td> </tr> </tbody> </table> <p>*X=LCD SIDE WIDTH t = GLASS THICKNESS L=ELECTRODE PAD LENGTH ①IF GLASS CHIPPING THE ITO TERMINAL, OVER 2/3 OF THE ITO MUST REMAIN AND BE, INSPECTED ACCORDING TO ELECTRODE TERMINAL SPECIFICATIONS ②IF THE PRODUCT WILL BE HEAT SEALED BY THE CUSTOMER, THE ALIGNMENT MARK MUST NOT BE DAMAGED</p>	a	b	c	$\leq t$	$\leq 1/8X$	$\leq L$					
a	b	c									
$\leq t$	$\leq 1/8X$	$\leq L$									

13.4 RELIABILITY TEST

13.4.1 STANDARD SPECIFICATIONS FOR RELIABILITY OF LCD MODULE

NO.	ITEM	DESCRIPTION
1	HIGH TEMPERATURE OPERATION	THE SAMPLE SHOULD BE ALLOWED TO STAND AT +70°C FOR 240 HRS
2	LOW TEMPERATURE OPERATION	THE SAMPLE SHOULD BE ALLOWED TO STAND AT -20°C FOR 240 HRS
3	HIGH TEMPERATURE STORAGE	THE SAMPLE SHOULD BE ALLOWED TO STAND AT +80°C FOR 240 HRS
4	LOW TEMPERATURE STORAGE	THE SAMPLE SHOULD BE ALLOWED TO STAND AT -30°C FOR 240 HRS
5	HIGH TEMPERATURE / HUMIDITY TEST STORAGE	THE SAMPLE SHOULD BE ALLOWED TO STAND AT 60°C, 90% RH 240 HRS
6	THERMAL SHOCK (NOT OPERATED)	<p>THE SAMPLE SHOULD BE ALLOWED TO STAND THE FOLLOWING 10 CYCLES OF OPERATION:</p>
7	ESD (ELECTROSTATIC DISCHARGE) (NOT OPERATED)	<p>AIR DISCHARGE ± 12KV CONTACT DISCHARGE ± 8KV (ACCORDING TO IEC-61000-4-2)</p>

NOTE ( 1 ) : THE TEST SAMPLES HAVE RECOVERY TIME FOR 2 HOURS AT ROOM TEMPERATURE BEFORE THE FUNCTION CHECK. IN THE STANDARD CONDITIONS, THERE IS NO DISPLAY FUNCTION NG ISSUE OCCURRED.

13.5 TESTING CONDITIONS AND INSPECTION CRITERIA

FOR THE FINAL TEST THE TESTING SAMPLE MUST BE STORED AT ROOM TEMPERATURE FOR 24 HOURS, AFTER THE TESTS LISTED IN TABLE 13.5, STANDARD SPECIFICATIONS FOR RELIABILITY HAVE BEEN EXECUTED IN ORDER TO ENSURE STABILITY.

NO.	ITEM	TEST MODEL	INSPECTION CRITERIA
1	CURRENT CONSUMPTION	REFER TO SPECIFICATION	THE CURRENT CONSUMPTION SHOULD CONFORM TO THE PRODUCT SPECIFICATION.
2	CONTRAST	REFER TO SPECIFICATION	AFTER THE TESTS HAVE BEEN EXECUTED, THE CONTRAST MUST BE LARGER THAN HALF OF ITS INITIAL VALUE PRIOR TO THE TESTS.
3	APPEARANCE	VISUAL INSPECTION	DEFECT FREE

13.6 OPERATION

13.6.1 DO NOT CONNECT OR DISCONNECT MODULES TO OR FROM THE MAIN SYSTEM WHILE POWER IS BEING SUPPLIED .

13.6.2 USE THE MODULE WITHIN SPECIFIED TEMPERATURE ; LOWER TEMPERATURE CAUSES THE RETARDATION OF BLINKING SPEED OF THE DISPLAY ; HIGHER TEMPERATURE MAKES OVERALL DISPLAY DISCOLOR. WHEN THE TEMPERATURE RETURNS TO NORMALITY, THE DISPLAY WILL OPERATE NORMALLY .

13.6.3 ADJUST THE LC DRIVING VOLTAGE TO OBTAIN THE OPTIMUM CONTRAST.

13.6.4 POWER ON SEQUENCE INPUT SIGNALS SHOULD NOT BE SUPPLIED TO LCD MODULE BEFORE POWER SUPPLY VOLTAGE IS APPLIED AND REACHES THE SPECIFIED VALUE .

IF ABOVE SEQUENCE IS NOT FOLLOWED , CMOS LSIS OF LCD MODULES MAY BE DAMAGED DUE TO LATCH - UP PROBLEM .

13.6.5 NOT ALLOWED TO INFLICT ANY EXTERNAL STRESS AND TO CAUSE ANY MECHANICAL INTERFERENCE ON THE BENDING AREA OF FPC DURING THE TAIL BENDING BACKWARDS!

DO NOT STRESS FPC AND IC ON THE MODULE!

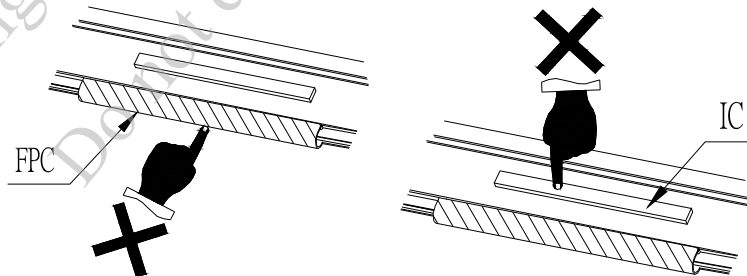

### 13.7 NOTICE

- 13.7.1 USE A GROUNDED SOLDERING IRON WHEN SOLDERING CONNECTOR I/O TERMINALS . FOR SOLDERING OR REPAIRING, TAKE PRECAUTION AGAINST THE TEMPERATURE OF THE SOLDERING IRON AND THE SOLDERING TIME TO PREVENT PEELING OFF THE THROUGH-HOLE-PAD .
- 13.7.2 DO NOT DISASSEMBLE . EDT SHALL NOT BE HELD RESPONSIBLE IF THE MODULE IS DISASSEMBLED AND UPON THE REASSEMBLY THE MODULE FAILED .
- 13.7.3 DO NOT CHARGE STATIC ELECTRICITY , AS THE CIRCUIT OF THIS MODULE CONTAINS CMOS LSIS. A WORKMAN'S BODY SHOULD ALWAYS BE STATIC-PROTECTED BY USE OF AN ESD STRAP. WORKING CLOTHES FOR SUCH PERSONNEL SHOULD BE OF STATIC-PROTECTED MATERIAL .
- 13.7.4 ALWAYS GROUND THE ELECTRICALLY-POWERED DRIVER BEFORE USING IT TO INSTALL THE LCD MODULE. WHILE CLEANING THE WORK STATION BY VACUUM CLEANER, DO NOT BRING THE SUCKING MOUTH NEAR THE MODULE ; STATIC ELECTRICITY OF THE ELECTRICALLY-POWERED DRIVER OR THE VACUUM CLEANER MAY DESTROY THE MODULE .
- 13.7.5 DON'T GIVE EXTERNAL SHOCK.
- 13.7.6 DON'T APPLY EXCESSIVE FORCE ON THE SURFACE.
- 13.7.7 LIQUID IN LCD IS HAZARDOUS SUBSTANCE. MUST NOT LICK AND SWALLOW.  
WHEN THE LIQUID IS ATTACH TO YOUR, SKIN, CLOTH ETC.  
WASH IT OUT THOROUGHLY AND IMMEDIATELY.
- 13.7.8 DON'T OPERATE IT ABOVE THE ABSOLUTE MAXIMUM RATING.
- 13.7.9 STORAGE IN A CLEAN ENVIRONMENT, FREE FROM DUST, ACTIVE GAS AND SOLVENT.
- 13.7.10 STORE WITHOUT ANY PHYSICAL LOAD.
- 13.7.11 REWIRING: NO MORE THAN 3 TIMES.