

EXAMINED BY : <i>Dan Kao</i>	EMERGING DISPLAY TECHNOLOGIES CORPORATION	FILE NO. CAS-0008431
APPROVED BY: <i>Justin Horng</i>		ISSUE : JUL.20, 2021
		TOTAL PAGE : 23
		VERSION : 4

CUSTOMER ACCEPTANCE SPECIFICATIONS

MODEL NO. :

ET070016DMA

(RoHS)

FOR MESSRS :

CUSTOMER'S APPROVAL

DATE :

BY :

RECORDS OF REVISION	DOC . FIRST ISSUE	MAR.06, 2017
---------------------	-------------------	--------------

DATE	REVISED PAGE NO.	SUMMARY
MAY.11, 2018	3	4. ELECTRICAL CHARACTERISTICS LED LIFE TIME : MIN.= — →50K, TYP.=50K→ —
	13	11.1 POWER SUPPLY FOR LCM NOTE (2) : 100~1KHz→100~10KHz
SEP.15, 2020	13	11.1 POWER SUPPLY FOR LCM NOTE(3): 
JUL.20, 2021	3	4. ELECTRICAL CHARACTERISTICS LOW LEVEL INPUT VOLTAGE: DELETE REMARK HIGH LEVEL INPUT VOLTAGE: DELETE REMARK POWER SUPPLY CURRENT: REMARK: NOTE (2)→NOTE (1)
<p>CONFIDENTIAL</p> <p>Authorized for</p> <p>Emerging Display Technologies Corporation Only</p> <p>Do not distribute without authorization.</p>		

TABLE OF CONTENTS

NO.	ITEM	PAGE
1.	GENERAL SPECIFICATIONS -----	1
2.	MECHANICAL SPECIFICATIONS -----	1
3.	ABSOLUTE MAXIMUM RATINGS -----	2
4.	ELECTRICAL CHARACTERISTICS -----	3
5.	TIMING CHARACTERISTICS -----	4 ~ 6
6.	OPTICAL CHARACTERISTICS -----	7, 8
7.	OUTLINE DIMENSIONS -----	9
8.	BLOCK DIAGRAM -----	10
9.	DETAIL DRAWING OF DOT MATRIX -----	11
10.	INTERFACE SIGNALS -----	12
11.	POWER SUPPLY -----	13
12.	INSPECTION CRITERION -----	14 ~ 23

CONFIDENTIAL
Authorized for
Emerging Display Technologies Corporation Only.
Do not distribute without authorization.

1. GENERAL SPECIFICATIONS

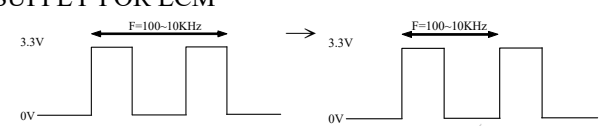
1.1 DATA SHEETS FOR CONTROLLER/DRIVER

PLEASE REFER TO :

SITRONIX ST5651CB
SITRONIX ST5021CA

1.2 MATERIAL SAFETY DESCRIPTION

ASSEMBLIES SHALL COMPLY WITH EUROPEAN ROHS REQUIREMENTS, INCLUDING PROHIBITED MATERIALS/COMPONENTS CONTAINING LEAD, MERCURY, CADMIUM, HEXAVALENT CHROMIUM, POLYBROMINATED BIPHENYLS (PBB) AND POLYBROMINATED DIPHENYL ETHERS (PBDE)

2. MECHANICAL SPECIFICATIONS

(1) DISPLAY SIZE	-----	7 inch
(2) NUMBER OF DOTS	-----	1024W * (RGB) * 600H DOTS
(3) MODULE SIZE	-----	166.2W * 99.7H * 9.5D(MAX.) mm (WITHOUT FPC)
(4) ACTIVE AREA	-----	154.2144W * 85.92H mm
(5) DOT SIZE	-----	0.0502W * 0.1432H mm
(6) PIXEL SIZE	-----	0.1506W * 0.1432H mm
(7) LCD TYPE	-----	TFT , TRANSMISSIVE, ANTI-GLARE, NORMAL BLACK
(8) COLOR	-----	16.7M
(9) VIEWING DIRECTION	-----	SUPER WIDE VIEW
(10) BACK LIGHT	-----	LED , COLOR : WHITE
(11) INTERFACE MODE	-----	LVDS

3. ABSOLUTE MAXIMUM RATINGS

3.1 ELECTRICAL ABSOLUTE MAXIMUM RATINGS

PARAMETER	SYMBOL	MIN.	MAX.	UNIT	REMARK
POWER SUPPLY VOLTAGE	VDD-VSS	-0.5	6.5	V	
INPUT VOLTAGE	VIN-VSS	-0.3	VDD+0.3	V	

3.2 ENVIRONMENTAL ABSOLUTE MAXIMUM RATINGS

ITEM	OPERATING		STORAGE		REMARK
	MIN.	MAX.	MIN.	MAX.	
AMBIENT TEMPERATURE	-20°C	70°C	-30°C	80°C	NOTE (1), (2)
HUMIDITY	NOTE (3)		NOTE (3)		WITHOUT CONDENSATION
VIBRATION	—	2.45 m/s ² (0.25 G)	—	11.76 m/s ² (1.2 G)	10~55Hz , X,Y,Z, EACH 2HRS
SHOCK	—	29.4 m/s ² (3 G)	—	490 m/s ² (50 G)	10 ms XYZ DIRECTIONS 1 TIME EACH
CORROSIVE GAS	NOT ACCEPTABLE		NOT ACCEPTABLE		

NOTE (1) : Ta AT -30°C : 48HRS MAX.
80°C : 48HRS MAX.

NOTE (2) : BACKGROUND COLOR CHANGES SLIGHTLY DEPENDING ON AMBIENT
TEMPERATURE THIS PHENOMENON IS REVERSIBLE.

NOTE (3) : Ta ≤ 60°C : 90%RH MAX. (48HRS MAX).

Ta > 60°C : ABSOLUTE HUMIDITY MUST BE LOWER THAN THE HUMIDITY
OF 60%RH AT 50°C (48HRS MAX).

4. ELECTRICAL CHARACTERISTICS

Ta = 25 °C

PARAMETER	SYMBOL	CONDITION	MIN.	TYP.	MAX.	UNIT	REMARK
POWER SUPPLY VOLTAGE	VDD-VSS	—	3.15	3.3	3.45	V	
POWER SUPPLY VOLTAGE FOR LED DRIVER	VCC-VSS	—	4.7	5	5.3	V	
LOW LEVEL INPUT VOLTAGE	VIL	—	0	—	0.3*VDD	V	
HIGH LEVEL INPUT VOLTAGE	VIH	—	0.7*VDD	—	VDD	V	
POWER SUPPLY CURRENT	IDD	VDD-VSS = 3.3V	—	130	160	mA	NOTE (1)
POWER SUPPLY CURRENT FOR LED DRIVER	ICC	VCC-VSS=5V LED B/L=ON	—	350	400	mA	
LED LIFE TIME	—	I _{LED} =20mA PER. LED	50K	—	—	hrs	NOTE (4) NOTE (5)

NOTE (1) : THE DISPLAY PATTERN IS ALL “BLACK”.

NOTE (2) : INTERNAL CIRCUIT DIAGRAM OF BACKLIGHT

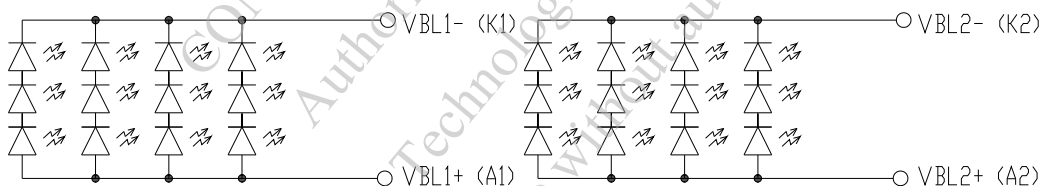

NOTE (3) : AMBIENT TEMP .VS. ALLOWABLE FORWARD CURRENT (PER LED)

Forward current derating curve
vs. ambient temperature

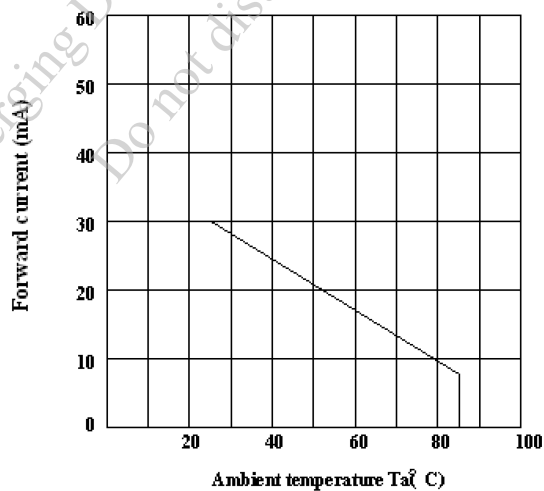

NOTE (4) : CONDITIONS; TA=25 °C, CONTINUOUS LIGHTING.

NOTE (5) : DEFINITIONS OF FAILURE

LCD LUMINANCE BECOMES HALF OF THE INITIAL VALUE.

5. TIMING CHARACTERISTICS

5.1 AC ELECTRICAL CHARACTERISTICS (LVDS)

PARAMETER	SYMBOL	CONDITION	MIN.	TYP.	MAX.	UNIT
CLOCK FREQUENCY	$R_{x\text{FCLK}}$	—	20	—	71	MHz
INPUT DATA SKEW MARGIN	T_{RSKM}	$ V_{\text{ID}} = 400\text{mV}$ $R_{\text{xVCM}} = 1.2\text{V}$ $R_{\text{xFCLK}} = 71\text{MHz}$	500	—	—	pS
CLOCK HIGH TIME	T_{LVCH}	—	—	$4/(7 * R_{\text{xFCLK}})$	—	ns
CLOCK LOW TIME	T_{LVCL}	—	—	$3/(7 * R_{\text{xFCLK}})$	—	ns
PLL WAKE-UP TIME	T_{enPLL}	—	—	—	150	μs

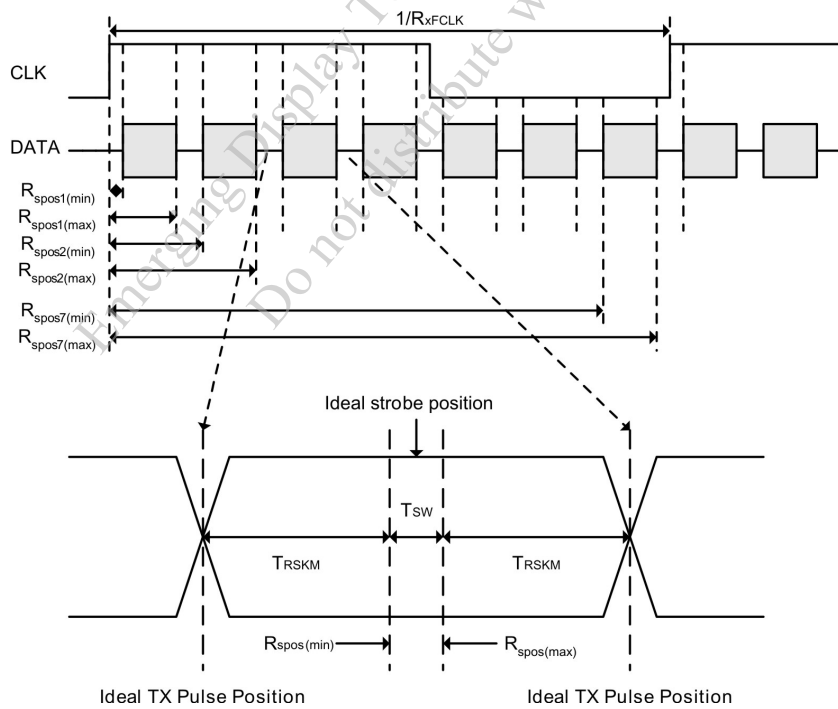
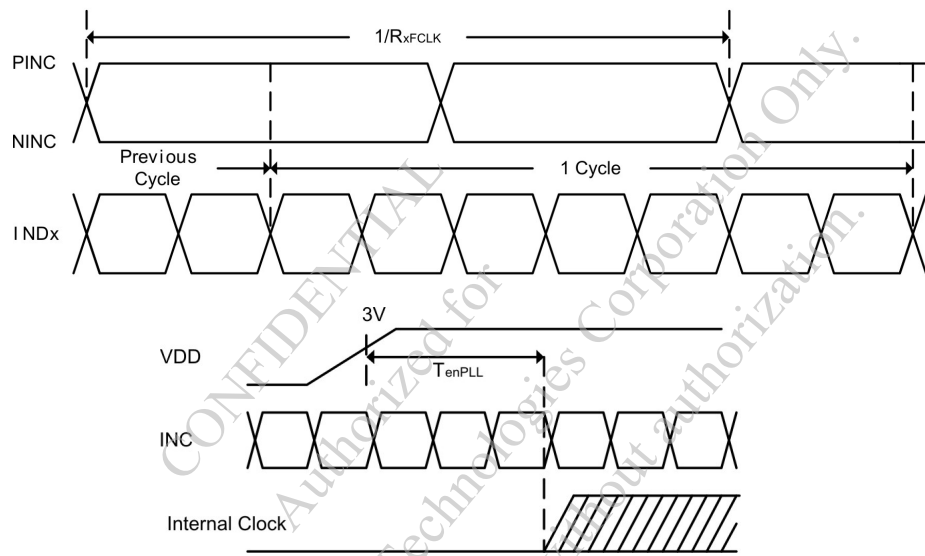

TRSKM : RECEIVER STROBE MARGIN
RSPOS : RECEIVER STROBE POSITION
TSW : STROBE WIDTH (INTERNAL DATA SAMPLING WINDOW)

PARAMETER	SYMBOL	CONDITION	MIN.	TYP.	MAX.	UNIT
MODULATION FREQUENCY	SSCMF	—	23	—	93	KHz
MODULATION RATE	SSCMR	LVDS clock = 71MHz CENTER SPREAD	—	—	±3	%

5.2 DC ELECTRICAL CHARACTERISTICS

PARAMETER	SYMBOL	MIN.	TYP.	MAX.	UNIT	REMARK
DIFFERENTIAL INPUT HIGH THRESHOLD VOLTAGE	R_{xvth}	—	—	+0.1	V	$R_{xvcm}=1.2V$
DIFFERENTIAL INPUT LOW THRESHOLD VOLTAGE	R_{xvtl}	-0.1	—	—	V	
INPUT VOLTAGE RANGE (SINGLED-END)	R_{xvin}	0	—	2.4	V	
DIFFERENTIAL INPUT COMMON MODE VOLTAGE	R_{xvcm}	$ V_{ID} /2$	—	$2.4- V_{ID} /2$	V	
DIFFERENTIAL VOLTAGE	$ V_{ID} $	0.2	—	0.6	V	
DIFFERENTIAL INPUT LEAKAGE CURRENT	R_{vxliz}	-10	—	+10	μA	
LVDS DIGITAL OPERATING CURRENT	LDDLVDs	—	40	50	mA	FCLK=65MHz VDD=3.3V
LVDS DIGITAL STAND-BY CURRENT	LSTLVDS	—	10	50	μA	CLOCK & ALL FUNCTIONS ARE STOPPED

Single end signals

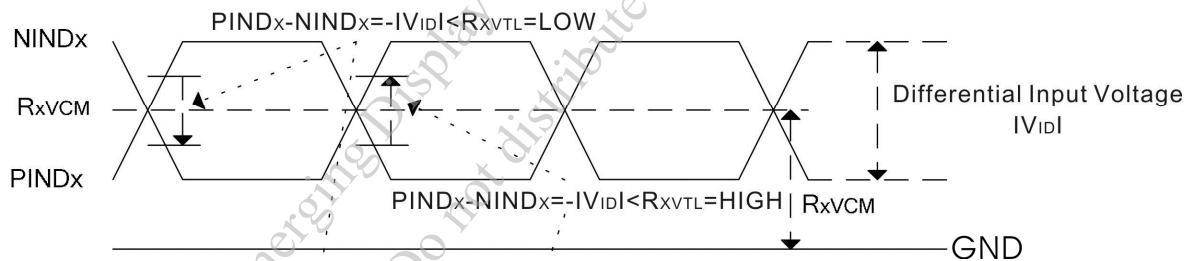

Differential signals

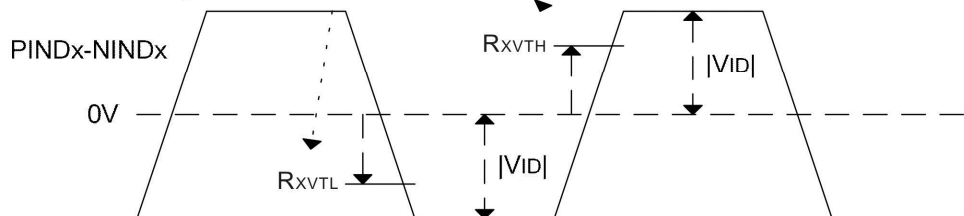

5.3 TIMING

PARAMETER	SYMBOL	MIN.	TYP.	MAX.	UNIT	REMARK
CLOCK FREQUENCY	fclk	40.8	51.2	67.2	MHz	FRAME RATE=60Hz
HORIZONTAL DISPLAY AREA	thd	1024			DCLK	
HS PERIOD TIME	th	1114	1344	1400	DCLK	
HS BLANKING	thb	90	320	376	DCLK	
VERTICAL DISPLAY AREA	tvd	600			H	
VS PERIOD TIME	tv	610	635	800	H	
VS BLANKING	tvd +tvfp	10	35	200	H	

DATA INPUT FORMAT

8-BIT LVDS INPUT

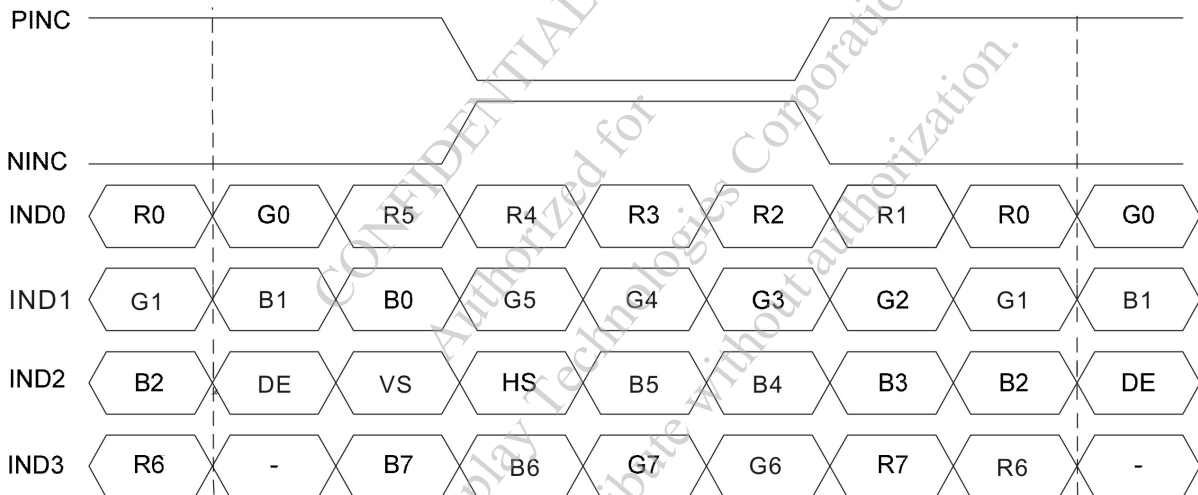

6. OPTICAL CHARACTERISTICS (NOTE 1)

6.1 OPTICAL CHARACTERISTICS

Ta = 25 ± 2 °C

ITEM	SYMBOL	CONDITION	MIN.	TYP.	MAX.	UNIT	REMARK	
VIEWING ANGLE	θ_{y+}	CR ≥ 10	$\theta_x=0^\circ$	80	85	—	deg.	NOTE (2) NOTE (3)
	θ_{y-}			80	85	—		
	θ_{x+}		$\theta_y=0^\circ$	80	85	—		
	θ_{x-}			80	85	—		
CONTRAST RATIO	CR	$\theta_x=0^\circ, \theta_y=0^\circ$	600	800	—	—	NOTE (3)	
RESPONSE TIME	T _R (rise)	$\theta_x=0^\circ, \theta_y=0^\circ$	—	13	20	msec	NOTE (4)	
	T _F (fall)		—	15	25			
COLOR OF CIE COORDINATE	WHITE	W _x	$\theta_x=0^\circ, \theta_y=0^\circ$ VCC-VSS=5V NTSC : 47 %	0.26	0.31	0.36	—	NOTE (5)
		W _y		0.28	0.33	0.38		
	RED	R _x		0.53	0.58	0.63		
		R _y		0.31	0.36	0.41		
	GREEN	G _x		0.30	0.35	0.40		
		G _y		0.53	0.58	0.63		
	BLUE	B _x		0.11	0.16	0.21		
		B _y		0.06	0.11	0.16		
THE BRIGHTNESS OF MODULE	B	$\theta_x=0^\circ, \theta_y=0^\circ$ VCC-VSS=5V	400	500	—	cd/m ²	NOTE (6)	
THE UNIFORMITY OF MODULE	—		70	75	—	%		

NOTE (1) : TEST EQUIPMENT SETUP :

AFTER STABILIZING AND LEAVING THE PANEL ALONE AT A GIVEN TEMPERATURE FOR 30 MINUTES. MEASUREMENT SHOULD BE EXECUTED IN A STABLE, WINDLESS, AND DARK ROOM. OPTICAL SPECIFICATIONS ARE MEASURED BY TOPCON BM-7 (FAST) WITH A VIEWING ANGLE OF 1° AT A DISTANCE OF 50cm AND NORMAL DIRECTION.

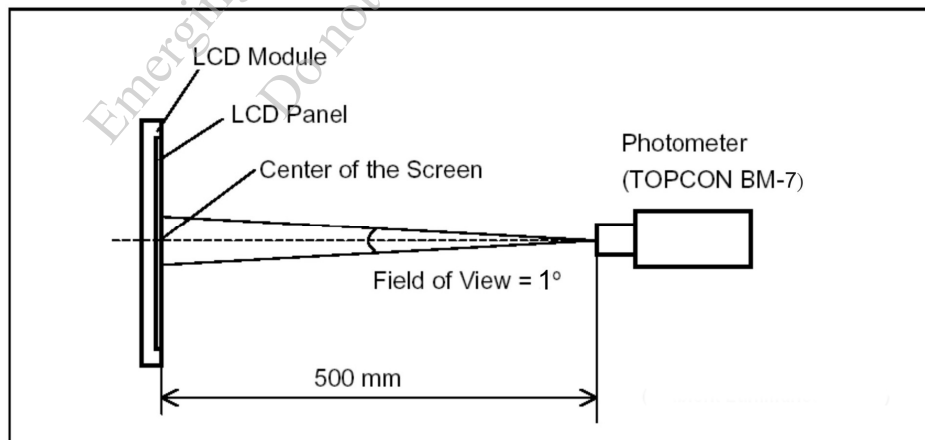

NOTE (2) : DEFINITION OF VIEWING ANGLE :

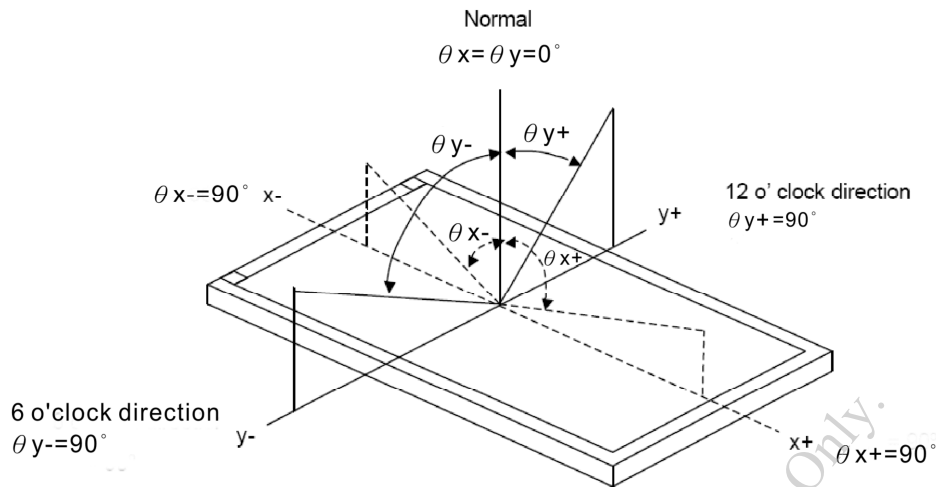

NOTE (3) : DEFINITION OF CONTRAST RATIO :

$$\text{CONTRAST RATIO(CR)} = \frac{\text{BRIGHTNESS MEASURED WHEN LCD IS AT "WHITE STATE"}}{\text{BRIGHTNESS MEASURED WHEN LCD IS AT "BLACK STATE"}}$$

NOTE (4) : DEFINITION OF RESPONSE TIME : T_R AND T_F

THE FIGURE BELOW IS THE OUTPUT SIGNAL OF THE PHOTO DETECTOR.

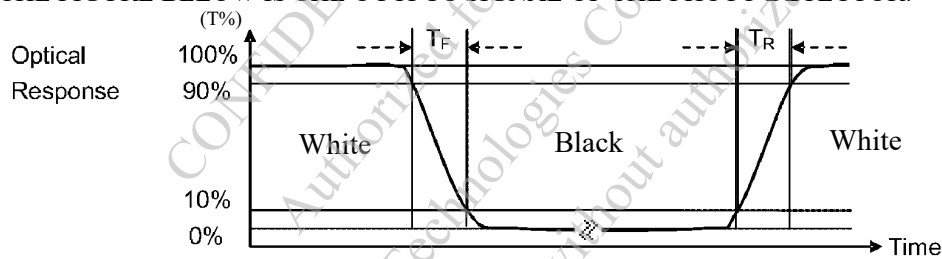

NOTE (5) : THE 100% TRANSMISSION IS DEFINED AS THE TRANSMISSION OF LCD PANEL WHEN ALL THE INPUT TERMINALS OF MODULE ARE ELECTRICALLY OPENED.

NOTE (6) : BRIGHTNESS MEASURED WHEN LCD IS AT "WHITE STATE"

6.2 THE TEST METHOD OF BRIGHTNESS AND UNIFORMITY

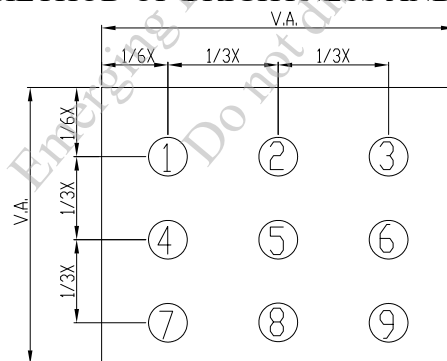

UNIT : mm

6.3 THE CALCULATING METHOD OF UNIFORMITY

$$\text{UNIFORMITY} = \left[1 - \frac{\text{MAXIMUM BRIGHTNESS} - \text{MINIMUM BRIGHTNESS}}{\text{AVERAGE BRIGHTNESS}} \right] \times 100\%$$

7. OUTLINE DIMENSIONS

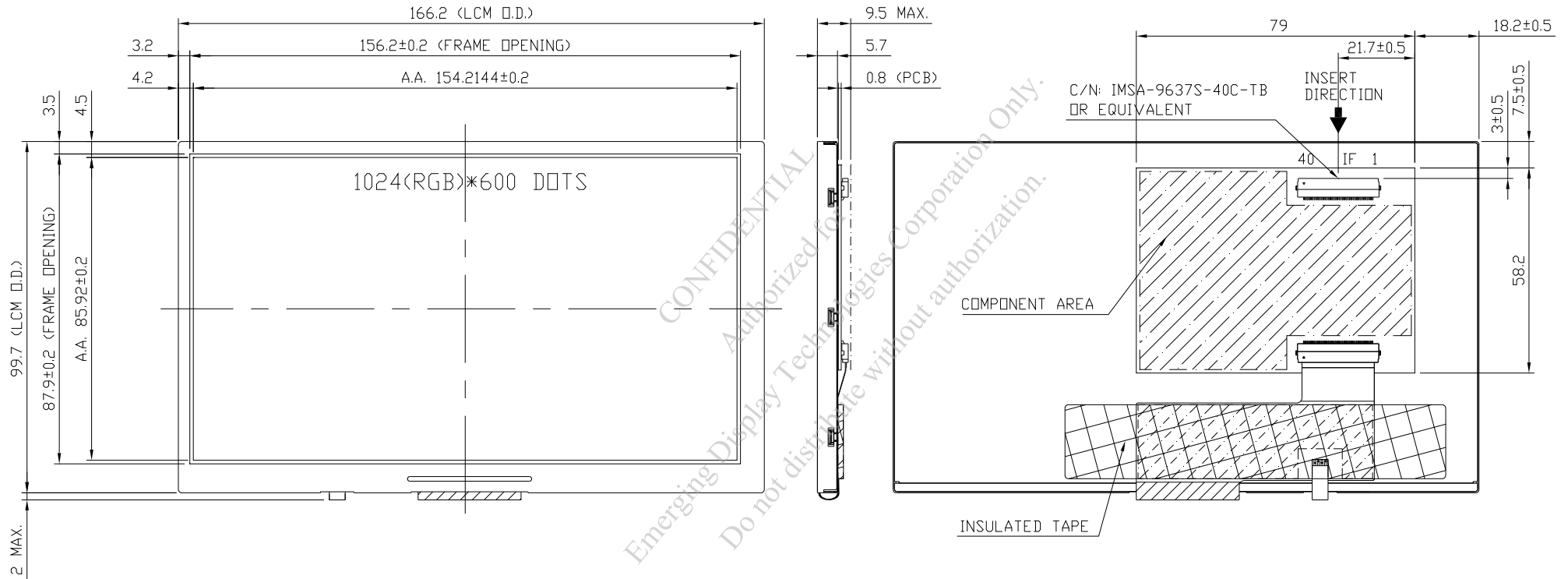

UNIT : mm
SCALE : NTS
NOT SPECIFIED TOLERANCE IS ± 0.3

8. BLOCK DIMENSION

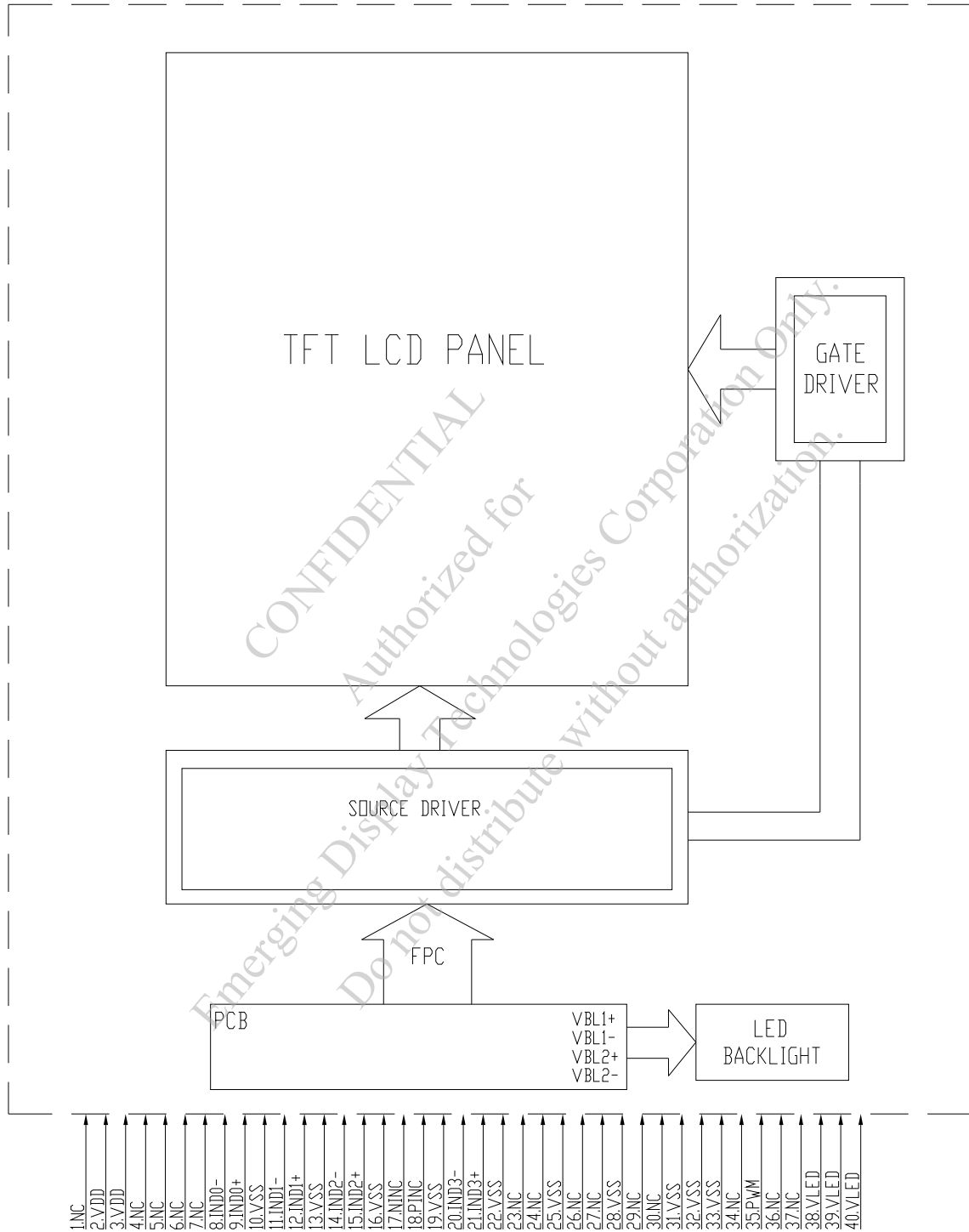

9. DETAIL DRAWING OF DOT MATRIX

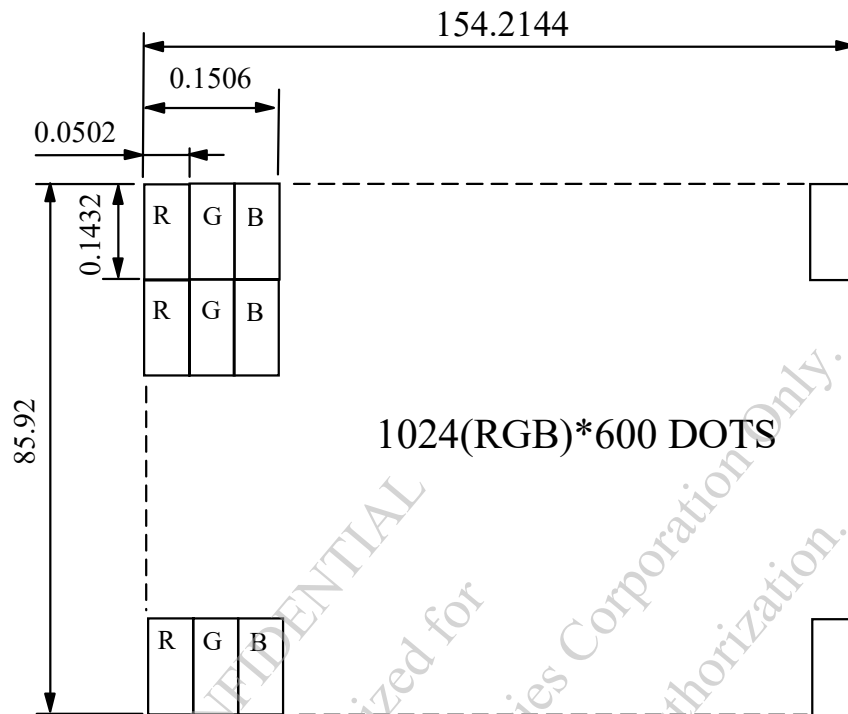

UNIT : mm
SCALE : NTS
NOT SPECIFIED TOLERANCE IS ± 0.1
DOTS MATRIX TOLERANCE IS ± 0.01

CONFIDENTIAL
Authorized for Emerging Display Technologies Corporation Only.
Do not distribute without authorization.

10. INTERFACE SIGNALS

PIN NO.	SYMBOL	FUNCTION
1	NC	NON CONNECTION
2	VDD	POWER SUPPLY VOLTAGE
3	VDD	POWER SUPPLY VOLTAGE
4	NC	NON CONNECTION
5	NC	NON CONNECTION
6	NC	NON CONNECTION
7	NC	NON CONNECTION
8	IND0-	LVDS SIGNAL (-) — CHANNEL 0 (R0~R5,G0)
9	IND0+	LVDS SIGNAL (+) — CHANNEL 0 (R0~R5,G0)
10	VSS	GROUND
11	IND1-	LVDS SIGNAL (-) — CHANNEL 1 (G1~G5,B0~B1)
12	IND1+	LVDS SIGNAL (+) — CHANNEL 1 (G1~G5,B0~B1)
13	VSS	GROUND
14	IND2-	LVDS SIGNAL (-) — CHANNEL 2 (B2~B5,VS,HS,DE)
15	IND2+	LVDS SIGNAL (+) — CHANNEL 2 (B2~B5,VS,HS,DE)
16	VSS	GROUND
17	NINC	LVDS CLOCK SIGNAL (-)
18	PINC	LVDS CLOCK SIGNAL (+)
19	VSS	GROUND
20	IND3-	LVDS SIGNAL (-) — CHANNEL 3 (R6,R7,G6,G7,B6,B7)
21	IND3+	LVDS SIGNAL (+) — CHANNEL 3 (R6,R7,G6,G7,B6,B7)
22	VSS	GROUND
23	NC	NON CONNECTION
24	NC	NON CONNECTION
25	VSS	GROUND
26	NC	NON CONNECTION
27	NC	NON CONNECTION
28	VSS	GROUND
29	NC	NON CONNECTION
30	NC	NON CONNECTION
31	VSS	GROUND
32	VSS	GROUND
33	VSS	GROUND
34	NC	NON CONNECTION
35	PWM	ADJUST FOR LED BRIGHTNESS
36	NC	NON CONNECTION
37	NC	NON CONNECTION
38	VLED	POWER SUPPLY VOLTAGE FOR LED BACKLIGHT
39	VLED	POWER SUPPLY VOLTAGE FOR BACKLIGHT
40	VLED	POWER SUPPLY VOLTAGE FOR LED BACKLIGHT

11. POWER SUPPLY

11.1 POWER SUPPLY FOR LCM

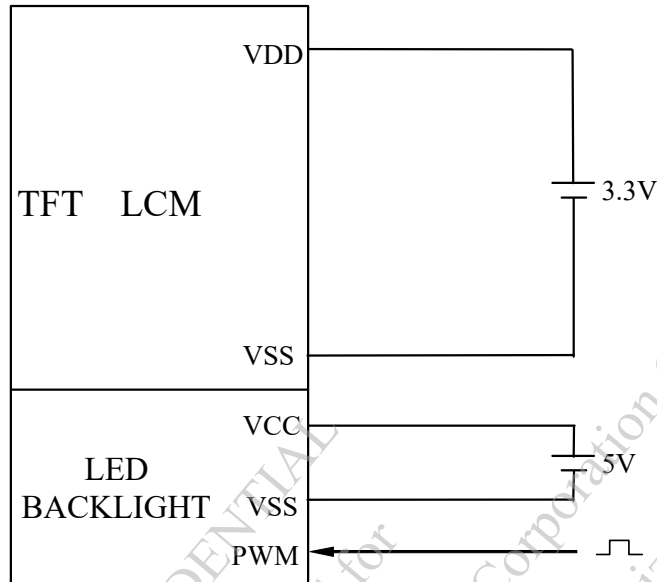

NOTE (1) : ADJUST THE PWM SIGNAL IN ORDER TO CONTROL LED BACKLIGHT'S BRIGHTNESS. THE HIGHER THE DUTY CYCLE, THE HIGHER THE BRIGHTNESS

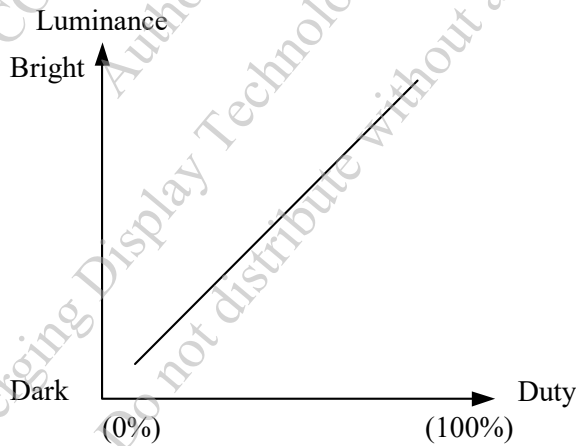

NOTE (2) : PWM SIGNAL OPERATION FREQUENCY IS 100~10KHz.

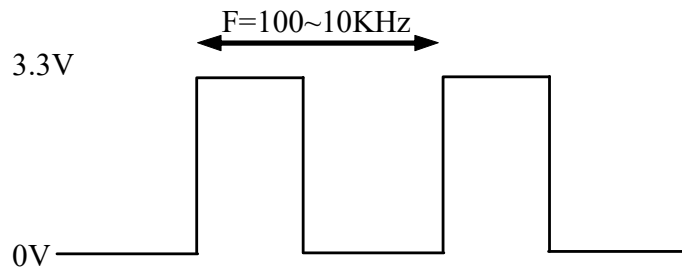

12. INSPECTION CRITERION

12.1 APPLICATION

THIS INSPECTION STANDARD IS TO BE APPLIED TO THE LCD MODULE DELIVERED FROM EMERGING DISPLAY TECHNOLOGIES CORP.(E.D.T) TO CUSTOMERS

12.2 INSPECTION CONDITIONS

12.2.1 (1)OBSERVATION DISTANCE : $35\pm 5\text{cm}$

(2)VIEW ANGLE :

NON-OPERATION CONDITION : $\pm 45^\circ$

(PERPENDICULAR TO LCD PANEL SURFACE)

OPERATION CONDITION : $\pm 5^\circ$

(PERPENDICULAR TO LCD PANEL SURFACE)

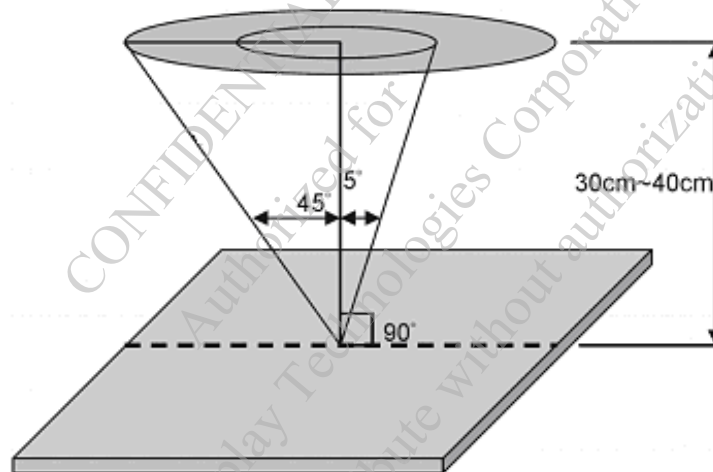

12.2.2 ENVIRONMENT CONDITIONS :

AMBIENT TEMPERATURE		20°C ~ 25°C
AMBIENT HUMIDITY		65 ± 20%RH
AMBIENT ILLUMINATION	COSMETIC INSPECTION	MORE THAN 600Lux
	FUNCTIONAL INSPECTION	300~500 Lux

12.2.3 INSPECTION LOT

QUANTITY PER DELIVERY LOT FOR EACH MODEL

12.2.4 A SAMPLING INSPECTION SHALL BE MADE ACCORDING TO THE FOLLOWING PROVISIONS TO JUDGE THE ACCEPTABILITY

(a)APPLICABLE STANDARD :

MIL-STD-105E

NORMAL INSPECTION, SINGLE SAMPLING

LEVEL II

(b)AQL : MAJOR DEFECT : AQL 0.65

MINOR DEFECT : AQL 1.0

12.3 INSPECTION STANDARDS

12.3.1 VISUAL DEFECTS CLASSIFICATION

TYPE OF DEFECT	INSPECTION ITEM	DEFECT FEATURE	AQL
MAJOR DEFECT	1.DISPLAY ON	<ul style="list-style-type: none"> • DEFECT TO MISS SPECIFIED DISPLAY FUNCTION, FOR ALL AND SPECIFIED DOTS EX: DISCONNECTION, SHORT CIRCUIT ETC 	0.65
	2.BACKLIGHT	<ul style="list-style-type: none"> • NO LIGHT • FLICKERING AND OTHER ABNORMAL ILLUMINATION 	
	3.DIMENSIONS	<ul style="list-style-type: none"> • SUBJECT TO INDIVIDUAL ACCEPTANCE SPECIFICATIONS 	
MINOR DEFECT	1.DISPLAY ZONE	<ul style="list-style-type: none"> • BLACK/WHITE SPOT • BUBBLES ON POLARIZER • NEWTON RING • BLACK/WHITE LINE • SCRATCH • CONTAMINATION • LEVER COLOR SPREAD 	1.0
	2.BEZEL ZONE	<ul style="list-style-type: none"> • STAINS • SCRATCHES • FOREIGN MATTER 	
	3.SOLDERING	<ul style="list-style-type: none"> • INSUFFICIENT SOLDER • SOLDERED IN INCORRECT POSITION • CONVEX SOLDERING SPOT • SOLDER BALLS • SOLDER SCRAPS 	
	4.DISPLAY ON (ALL ON)	<ul style="list-style-type: none"> • LIGHT LINE 	

12.3.2 MODULE DEFECTS CLASSIFICATION

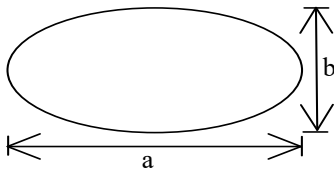
NO.	ITEM	CRITERIA												
1	DISPLAY ON INSPECTION	(1)INCORRECT PATTERN (2)MISSING SEGMENT (3)DIM SEGMENT (4)OPERATING VOLTAGE BEYOND SPEC												
2	OVERALL DIMENSIONS	(1)OVERALL DIMENSION BEYOND SPEC												
3	DOT DEFECT	(1)INSPECTION PATTERN: FULL WHITE, FULL BLACK, RED, GREEN AND BLUE SCREENS. (2) <table border="1" style="margin-left: 20px;"> <thead> <tr> <th>ITEMS</th> <th>ACCEPTABLE COUNT</th> </tr> </thead> <tbody> <tr> <td>BRIGHT DOT</td> <td>$N \leq 1$</td> </tr> <tr> <td>DARK DOT</td> <td>$N \leq 4$</td> </tr> <tr> <td>TOTAL BRIGHT AND DARK DOTS</td> <td>$N \leq 5$</td> </tr> </tbody> </table> <p>NOTE :</p> <p>1. THE DEFINITION OF DOT : THE SIZE OF A DEFECTIVE DOT OVER 1/2 OF WHOLE DOT IS REGARDED AS ONE DEFECTIVE DOT.</p> <p>2. BRIGHT DOT : DOTS APPEAR BRIGHT AND UNCHANGED IN SIZE IN WHICH LCD PANEL IS DISPLAYING UNDER BLACK PATTERN. THE BRIGHT DOT DEFECT MUST BE VISIBLE THROUGH 2% ND FILTER.</p> <p>3. DARK DOT : DOTS APPEAR DARK AND UNCHANGED IN SIZE IN WHICH LCD PANEL IS DISPLAYING UNDER PURE RED, GREEN, BLUE PICTURE.</p>	ITEMS	ACCEPTABLE COUNT	BRIGHT DOT	$N \leq 1$	DARK DOT	$N \leq 4$	TOTAL BRIGHT AND DARK DOTS	$N \leq 5$				
ITEMS	ACCEPTABLE COUNT													
BRIGHT DOT	$N \leq 1$													
DARK DOT	$N \leq 4$													
TOTAL BRIGHT AND DARK DOTS	$N \leq 5$													
4	FOREIGN BLACK/WHITE/ BRIGHT LINE/ SCRATCH OF VIEWING AREA	<table border="1" style="margin-left: 20px;"> <thead> <tr> <th>LENGTH : L</th> <th>WIDTH : W</th> <th>PERMISSIBLE NO.</th> </tr> </thead> <tbody> <tr> <td>$L \leq 0.3$</td> <td>$W \leq 0.05$</td> <td>IGNORE</td> </tr> <tr> <td>$0.3 < L \leq 2.5$</td> <td>$0.05 < W \leq 0.1$</td> <td>6</td> </tr> <tr> <td>$2.5 < L$</td> <td>$0.1 < W$</td> <td>NONE</td> </tr> </tbody> </table> <p>WIDTH : W mm, LENGTH : L mm</p>	LENGTH : L	WIDTH : W	PERMISSIBLE NO.	$L \leq 0.3$	$W \leq 0.05$	IGNORE	$0.3 < L \leq 2.5$	$0.05 < W \leq 0.1$	6	$2.5 < L$	$0.1 < W$	NONE
LENGTH : L	WIDTH : W	PERMISSIBLE NO.												
$L \leq 0.3$	$W \leq 0.05$	IGNORE												
$0.3 < L \leq 2.5$	$0.05 < W \leq 0.1$	6												
$2.5 < L$	$0.1 < W$	NONE												
5	FOREIGN MATTER \ BLACK SPOTS \ WHITE SPOTS \ DENT (INCLUDING LIGHT LEAKAGE DUE TO POLARIZING PLATES PINHOLES, ETC.)	<table border="1" style="margin-left: 20px;"> <thead> <tr> <th>AVERAGE DIAMETER (mm): D</th> <th>NUMBER OF PIECES PERMITTED</th> </tr> </thead> <tbody> <tr> <td>$D \leq 0.25$</td> <td>IGNORE</td> </tr> <tr> <td>$0.25 < D \leq 0.5$</td> <td>4</td> </tr> <tr> <td>$0.5 < D$</td> <td>NONE</td> </tr> </tbody> </table> <p>NOTE : DIAMETER $D=(a+b)/2$</p> 	AVERAGE DIAMETER (mm): D	NUMBER OF PIECES PERMITTED	$D \leq 0.25$	IGNORE	$0.25 < D \leq 0.5$	4	$0.5 < D$	NONE				
AVERAGE DIAMETER (mm): D	NUMBER OF PIECES PERMITTED													
$D \leq 0.25$	IGNORE													
$0.25 < D \leq 0.5$	4													
$0.5 < D$	NONE													

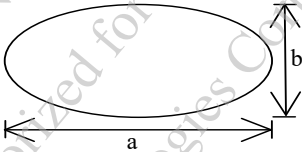
NO.	ITEM	CRITERIA		
			AVERAGE DIAMETER (mm) : D	NUMBER OF PIECES PERMITTED
6	BUBBLES OF POLARIZER /DIRT/CF FAIL /SURFACE STAINS	BUBBLE ON THE POLARIZER	$D \leq 0.25$	IGNORE
			$0.25 < D \leq 0.5$	$N \leq 5$
			$0.5 < D$	NONE
		SURFACE STAINS	$D < 0.1$	IGNORE
			$0.1 < D \leq 0.3$	$N \leq 3$
		CF FAIL / SPOT	$D < 0.1$	IGNORE
$0.1 < D \leq 0.3$	$N \leq 3$			
		<p>NOTE : (1)POLARIZER BUBBLE IS DEFINED AS THE BUBBLE APPEARS ON ACTIVE DISPLAY AREA. THE DEFECT OF POLARIZER BUBBLE SHALL BE IGNORED IF THE POLARIZER BUBBLE APPEARS ON THE OUTSIDE OF ACTIVE DISPLAY AREA.</p> <p>(2)THE EXTRANEIOUS SUBSTANCE IS DEFINED AS IT CAN BE OBSERVED WHEN THE MODULE IS POWER ON.</p> <p>(3)THE DEFINITION OF AVERAGE DIAMETER, D IS DEFINED AS FOLLOWING.</p> <p>AVERAGE DIAMETER (D)=(a+b)/2</p> 		
7	LINE DEFECT ON DISPLAY	OBVIOUS VERTICAL OR HORIZONTAL LINE DEFECT IS NOT ALLOWED		
8	MURA ON DISPLAY	IT'S OK IF MURA IS SLIGHT VISIBLE THROUGH 5% ND FILTER		
9	UNEVEN COLOR SPREAD, COLORATION	(1)TO BE DETERMINED BASED UPON THE STANDARD SAMPLE.		
10	BEZEL APPEARANCE	(1)BEZEL MAY NOT HAVE RUST, BE DEFORMED OR HAVE FINGER PRINTS STAINS OF OTHER CONTAMINATION. (2)BEZEL MUST COMPLY WITH JOB SPECIFICATIONS.		
11	PCB	<p>(1)THERE MAY NOT BE MORE THAN 2mm OF SEALANT OUTSIDE THE SEAL AREA ON THE PCB, AND THERE SHOULD BE NO MORE THAN THREE PLACES.</p> <p>(2)NO OXIDATION OR CONTAMINATION PCB TERMINALS.</p> <p>(3)PARTS ON PCB MUST BE THE SAME AS ON THE PRODUCTION CHARACTERISTIC CHART. THERE SHOULD BE NO WRONG PARTS, MISSING PARTS OR EXCESS PARTS.</p> <p>(4)THE JUMPER ON THE PCB SHOULD CONFORM TO THE PRODUCT CHARACTERISTIC CHART.</p> <p>(5)IF SOLDER GETS ON BEZEL TAB PADS, LED PAD, ZEBRA PAD OR SCREW HOLD PAD; MAKE SURE IT IS SMOOTHED DOWN.</p>		

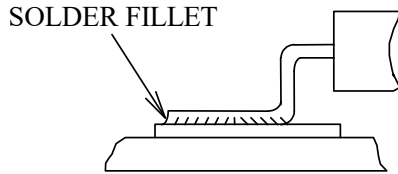
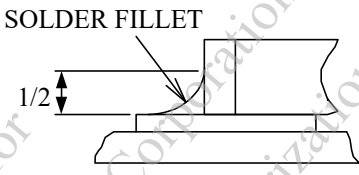
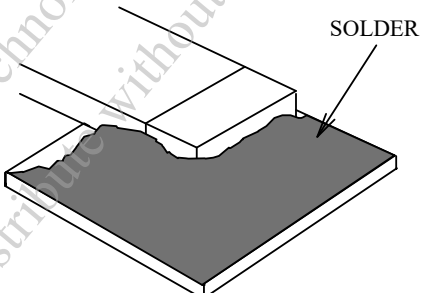
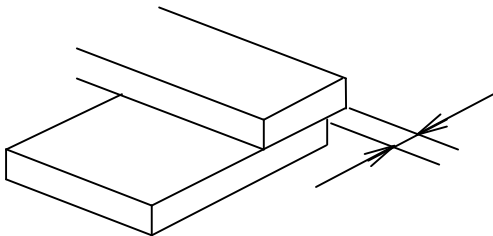
NO.	ITEM	CRITERIA
12	SOLDERING	<p>(1) NO SOLDERING FOUND ON THE SPECIFIED PLACE</p> <p>(2) INSUFFICIENT SOLDER</p> <p>(a) LSI, IC A POOR WETTING OF SOLDER IS BETWEEN LOWER BEND OR "HEEL" OF LEAD AND PAD</p>  <p>(b) CHIP COMPONENT · SOLDER IS LESS THAN 50% OF SIDES AND FRONT FACE WETTING</p>  <p>· SOLDER WETS 3 SIDES OF TERMINAL, BUT LESS THAN 25% OF SIDES AND FRONT SURFACE AREA ARE COVERED</p>  <p>(3) PARTS ALIGNMENT</p> <p>(a) LSI, IC LEAD WIDTH IS MORE THAN 50% BEYOND PAD OUTLINE</p> 

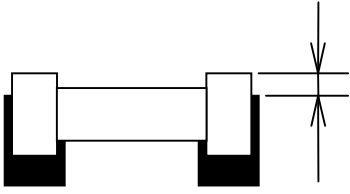
NO.	ITEM	CRITERIA
12	SOLDERING	<p>(b)CHIP COMPONENT COMPONENT IS OFF CENTER, AND MORE THAN 50% OF THE LEADS IS OFF THE PAD OUTLINE</p>  <p>(4)NO UNMELTED SOLDER PASTE MAY BE PRESENT ON THE PCB. (5)NO COLD SOLDER JOINTS, MISSING SOLDER CONNECTIONS, OXIDATION OR ICICLE. (6)NO RESIDUE OR SOLDER BALLS ON PCB. (7)NO SHORT CIRCUITS IN COMPONENTS ON PCB.</p>
13	BACKLIGHT	<p>(1)NO LIGHT (2)FLICKERING AND OTHER ABNORMAL ILLUMINATION (3)SPOTS OR SCRATCHES THAT APPEAR WHEN LIT MUST BE JUDGED USING LCD SPOT, LINES AND CONTAMINATION STANDARDS. (4)BACKLIGHT DOESN'T LIGHT OR COLOR IS WRONG.</p>
14	GENERAL APPEARANCE	<p>(1)NO OXIDATION, CONTAMINATION, CURVES OR, BENDS ON INTERFACE PIN (OLB) OF TCP. (2)NO CRACKS ON INTERFACE PIN (OLB) OF TCP. (3)NO CONTAMINATION, SOLDER RESIDUE OR SOLDER BALLS ON PRODUCT. (4)THE IC ON THE TCP MAY NOT BE DAMAGED, CIRCUITS. (5)THE UPPERMOST EDGE OF THE PROTECTIVE STRIP ON THE INTERFACE PIN MUST BE PRESENT OR LOOK AS IF IT CAUSE THE INTERFACE PIN TO SEVER. (6)THE RESIDUAL ROSIN OR TIN OIL OF SOLDERING (COMPONENT OR CHIP COMPONENT) IS NOT BURNED INTO BROWN OR BLACK COLOR. (7)SEALANT ON TOP OF THE ITO CIRCUIT HAS NOT HARDENED. (8)PIN TYPE MUST MATCH TYPE IN SPECIFICATION SHEET. (9)LCD PIN LOOSE OR MISSING PINS. (10)PRODUCT PACKAGING MUST THE SAME AS SPECIFIED ON PACKAGING SPECIFICATION SHEET. (11)PRODUCT DIMENSION AND STRUCTURE MUST CONFORM TO PRODUCT SPECIFICATION SHEET. (12)THE APPEARANCE OF HEAT SEAL SHOULD NOT ADMIT ANY DIRT AND BREAK.</p>

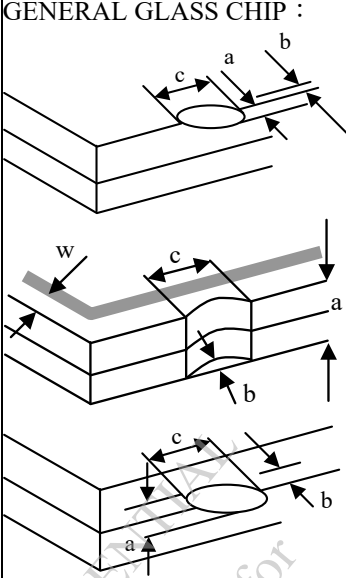
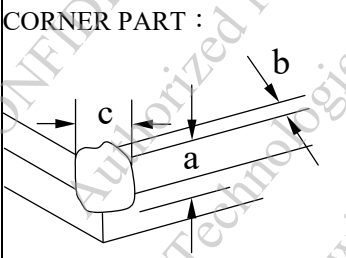
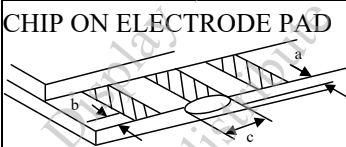
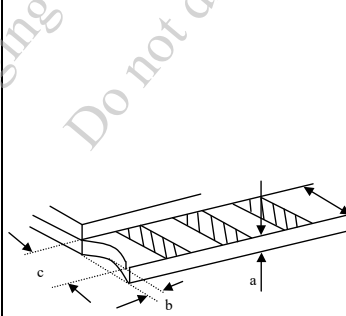
NO.	ITEM	CRITERIA									
15	CRACKED GLASS	<p>THE LCD WITH EXTENSIVE CRACK IS NOT ACCEPTABLE</p> <p>GENERAL GLASS CHIP :</p>  <table border="1"> <thead> <tr> <th>a</th> <th>b</th> <th>c</th> </tr> </thead> <tbody> <tr> <td>$\leq t/2$</td> <td>< VIEWING AREA</td> <td>$\leq 1/8X$</td> </tr> <tr> <td>$t/2 > , \leq 2t$</td> <td>$\leq W/2$</td> <td>$\leq 1/8X$</td> </tr> </tbody> </table> <p>*W=DISTANCE BETWEEN SEALANT AREA AND LCD PANEL EDGE X = LCD SIDE LENGTH t = GLASS THICKNESS</p>	a	b	c	$\leq t/2$	< VIEWING AREA	$\leq 1/8X$	$t/2 > , \leq 2t$	$\leq W/2$	$\leq 1/8X$
		a	b	c							
		$\leq t/2$	< VIEWING AREA	$\leq 1/8X$							
		$t/2 > , \leq 2t$	$\leq W/2$	$\leq 1/8X$							
		<p>CORNER PART :</p>  <table border="1"> <thead> <tr> <th>a</th> <th>b</th> <th>c</th> </tr> </thead> <tbody> <tr> <td>$\leq t/2$</td> <td>< VIEWING AREA</td> <td>$\leq 1/8X$</td> </tr> <tr> <td>$> t/2 , \leq 2t$</td> <td>$\leq W/2$</td> <td>$\leq 1/8X$</td> </tr> </tbody> </table> <p>*W=DISTANCE BETWEEN SEALANT AREA AND LCD PANEL EDGE X = LCD SIDE LENGTH t = GLASS THICKNESS</p>	a	b	c	$\leq t/2$	< VIEWING AREA	$\leq 1/8X$	$> t/2 , \leq 2t$	$\leq W/2$	$\leq 1/8X$
a	b	c									
$\leq t/2$	< VIEWING AREA	$\leq 1/8X$									
$> t/2 , \leq 2t$	$\leq W/2$	$\leq 1/8X$									
<p>CHIP ON ELECTRODE PAD</p>  <table border="1"> <thead> <tr> <th>a</th> <th>b</th> <th>c</th> </tr> </thead> <tbody> <tr> <td>$\leq t$</td> <td>$\leq 0.5\text{mm}$</td> <td>$\leq 1/8X$</td> </tr> </tbody> </table> <p>*X=LCD SIDE WIDTH t=GLASS THICKNESS</p>	a	b	c	$\leq t$	$\leq 0.5\text{mm}$	$\leq 1/8X$					
a	b	c									
$\leq t$	$\leq 0.5\text{mm}$	$\leq 1/8X$									
 <table border="1"> <thead> <tr> <th>a</th> <th>b</th> <th>c</th> </tr> </thead> <tbody> <tr> <td>$\leq t$</td> <td>$\leq 1/8X$</td> <td>$\leq L$</td> </tr> </tbody> </table> <p>*X=LCD SIDE WIDTH t = GLASS THICKNESS L=ELECTRODE PAD LENGTH</p> <p>①IF GLASS CHIPPING THE ITO TERMINAL, OVER 2/3 OF THE ITO MUST REMAIN AND BE, INSPECTED ACCORDING TO ELECTRODE TERMINAL SPECIFICATIONS</p> <p>②IF THE PRODUCT WILL BE HEAT SEALED BY THE CUSTOMER, THE ALIGNMENT MARK MUST NOT BE DAMAGED</p>	a	b	c	$\leq t$	$\leq 1/8X$	$\leq L$					
a	b	c									
$\leq t$	$\leq 1/8X$	$\leq L$									

12.4 RELIABILITY TEST

12.4.1 STANDARD SPECIFICATIONS FOR RELIABILITY OF LCD MODULE

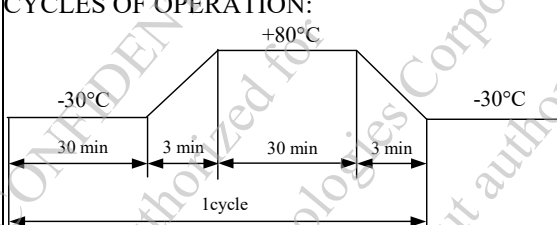
NO.	ITEM	DESCRIPTION
1	HIGH TEMPERATURE OPERATION	THE SAMPLE SHOULD BE ALLOWED TO STAND AT +70°C FOR 240 HRS
2	LOW TEMPERATURE OPERATION	THE SAMPLE SHOULD BE ALLOWED TO STAND AT -20°C FOR 240 HRS
3	HIGH TEMPERATURE STORAGE	THE SAMPLE SHOULD BE ALLOWED TO STAND AT +80°C FOR 240 HRS
4	LOW TEMP STORAGE	THE SAMPLE SHOULD BE ALLOWED TO STAND AT -30°C FOR 240 HRS
5	HIGH TEMPERATURE /HUMIDITY TEST STORAGE	THE SAMPLE SHOULD BE ALLOWED TO STAND AT 60°C, 90% RH 240 HRS
6	THERMAL SHOCK (NOT OPERATED)	THE SAMPLE SHOULD BE ALLOWED TO STAND THE FOLLOWING 10 CYCLES OF OPERATION: 
7	ESD (ELECTROSTATIC DISCHARGE) (NOT OPERATED)	AIR DISCHARGE ± 12KV CONTACT DISCHARGE ± 8KV ACCORDING TO IEC-61000-4-2

NOTE (1) : THE TEST SAMPLES HAVE RECOVERY TIME FOR 2 HOURS AT ROOM TEMPERATURE BEFORE THE FUNCTION CHECK. IN THE STANDARD CONDITIONS, THERE IS NO DISPLAY FUNCTION NG ISSUE OCCURRED.

12.5 TESTING CONDITIONS AND INSPECTION CRITERIA

FOR THE FINAL TEST THE TESTING SAMPLE MUST BE STORED AT ROOM TEMPERATURE FOR 24 HOURS, AFTER THE TESTS LISTED IN TABLE 12.5, STANDARD SPECIFICATIONS FOR RELIABILITY HAVE BEEN EXECUTED IN ORDER TO ENSURE STABILITY.

NO.	ITEM	TEST MODEL	INSPECTION CRITERIA
1	CURRENT CONSUMPTION	REFER TO SPECIFICATION	THE CURRENT CONSUMPTION SHOULD CONFORM TO THE PRODUCT SPECIFICATION.
2	CONTRAST	REFER TO SPECIFICATION	AFTER THE TESTS HAVE BEEN EXECUTED, THE CONTRAST MUST BE LARGER THAN HALF OF ITS INITIAL VALUE PRIOR TO THE TESTS.
3	APPEARANCE	VISUAL INSPECTION	DEFECT FREE

12.6 OPERATION

- 12.6.1 DO NOT CONNECT OR DISCONNECT MODULES TO OR FROM THE MAIN SYSTEM WHILE POWER IS BEING SUPPLIED .
- 12.6.2 USE THE MODULE WITHIN SPECIFIED TEMPERATURE ; LOWER TEMPERATURE CAUSES THE RETARDATION OF BLINKING SPEED OF THE DISPLAY ; HIGHER TEMPERATURE MAKES OVERALL DISPLAY DISCOLOR. WHEN THE TEMPERATURE RETURNS TO NORMALITY, THE DISPLAY WILL OPERATE NORMALLY .
- 12.6.3 ADJUST THE LC DRIVING VOLTAGE TO OBTAIN THE OPTIMUM CONTRAST.
- 12.6.4 POWER ON SEQUENCE INPUT SIGNALS SHOULD NOT BE SUPPLIED TO LCD MODULE BEFORE POWER SUPPLY VOLTAGE IS APPLIED AND REACHES THE SPECIFIED VALUE .
IF ABOVE SEQUENCE IS NOT FOLLOWED , CMOS LSIS OF LCD MODULES MAY BE DAMAGED DUE TO LATCH - UP PROBLEM .
- 12.6.5 NOT ALLOWED TO INFLICT ANY EXTERNAL STRESS AND TO CAUSE ANY MECHANICAL INTERFERENCE ON THE BENDING AREA OF FPC DURING THE TAIL BENDING BACKWARDS!
DO NOT STRESS FPC AND IC ON THE MODULE!

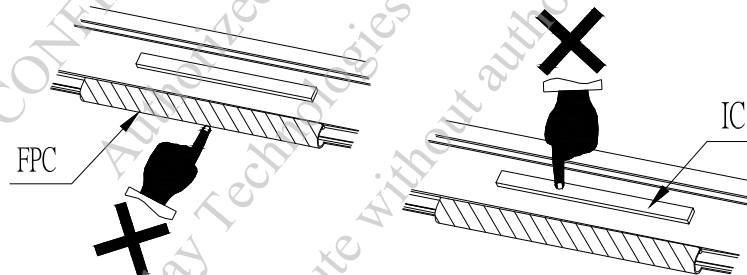

12.7 NOTICE

- 12.7.1 USE A GROUNDED SOLDERING IRON WHEN SOLDERING CONNECTOR I/O TERMINALS . FOR SOLDERING OR REPAIRING, TAKE PRECAUTION AGAINST THE TEMPERATURE OF THE SOLDERING IRON AND THE SOLDERING TIME TO PREVENT PEELING OFF THE THROUGH-HOLE-PAD .
- 12.7.2 DO NOT DISASSEMBLE . EDT SHALL NOT BE HELD RESPONSIBLE IF THE MODULE IS DISASSEMBLED AND UPON THE REASSEMBLY THE MODULE FAILED .
- 12.7.3 DO NOT CHARGE STATIC ELECTRICITY , AS THE CIRCUIT OF THIS MODULE CONTAINS CMOS LSIS. A WORKMAN'S BODY SHOULD ALWAYS BE STATIC-PROTECTED BY USE OF AN ESD STRAP. WORKING CLOTHES FOR SUCH PERSONNEL SHOULD BE OF STATIC-PROTECTED MATERIAL .
- 12.7.4 ALWAYS GROUND THE ELECTRICALLY-POWERED DRIVER BEFORE USING IT TO INSTALL THE LCD MODULE. WHILE CLEANING THE WORK STATION BY VACUUM CLEANER, DO NOT BRING THE SUCKING MOUTH NEAR THE MODULE ; STATIC ELECTRICITY OF THE ELECTRICALLY-POWERED DRIVER OR THE VACUUM CLEANER MAY DESTROY THE MODULE .
- 12.7.5 DON'T GIVE EXTERNAL SHOCK.
- 12.7.6 DON'T APPLY EXCESSIVE FORCE ON THE SURFACE.
- 12.7.7 LIQUID IN LCD IS HAZARDOUS SUBSTANCE. MUST NOT LICK AND SWALLOW.
WHEN THE LIQUID IS ATTACH TO YOUR, SKIN, CLOTH ETC.
WASH IT OUT THOROUGHLY AND IMMEDIATELY.
- 12.7.8 DON'T OPERATE IT ABOVE THE ABSOLUTE MAXIMUM RATING.
- 12.7.9 STORAGE IN A CLEAN ENVIRONMENT, FREE FROM DUST, ACTIVE GAS, AND SOLVENT.
- 12.7.10 STORE WITHOUT ANY PHYSICAL LOAD.
- 12.7.11 REWIRING: NO MORE THAN 3 TIMES.