

EXAMINED BY :  <i>Yung Chang Hu</i>	<b>EMERGING DISPLAY</b>  TECHNOLOGIES CORPORATION	FILE NO . CAS-0006533
APPROVED BY:		ISSUE : JUL.21, 2008
<i>David Chang</i>		TOTAL PAGE : 30
		VERSION : 2

CUSTOMER                      ACCEPTANCE                      SPECIFICATIONS

MODEL NO. :

ET057005DHU

(RoHS)

FOR MESSRS :

\_\_\_\_\_

CUSTOMER'S APPROVAL

DATE :

\_\_\_\_\_

BY :

\_\_\_\_\_

RECORDS OF REVISION NOV.14, 2007

DATE	REVISED PAGE NO.	SUMMARY																															
JUL.21, 2008	1	2. MECHANICAL SPECIFICATIONS (1)DISPLAY SIZE (inch) : 5.7" → 5.7 inch ADD (12) INTERFACE MODE																															
	3	4. ELECTRICAL CHARACTERISTICS ADD NOTE (2)																															
	6	6.1 OPTICAL CHARACTERISTICS NOTE (1) : 2° → 1°																															
	7	6.2 THE TEST METHOD OF BRIGHTNESS AND UNIFORMITY  6.3 THE CALCULATING METHOD OF UNIFORMITY UNIFORMITY: $\left[ 1 - \frac{\text{MAXIMUM BRIGHTNESS} - \text{MINIMUM BRIGHTNESS}}{\text{AVERAGE BRIGHTNESS}} \right] \times 100\% \rightarrow$ UNIFORMITY: $\left[ 1 - \frac{\text{MAXIMUM BRIGHTNESS} - \text{MINIMUM BRIGHTNESS}}{\text{AVERAGE BRIGHTNESS}} \right] \times 100\%$																															
	8	7. OUTLINE DIMENSIONS MARK $\triangle$ : ADD NOTE																															
	11	10. INTERFACE SIGNAL <table border="1" data-bbox="582 1153 1061 1220"> <tr> <th>PIN NO.</th> <th>SYMBOL</th> <th>I/O</th> <th>FUNCTION</th> </tr> <tr> <td>26</td> <td>DEN</td> <td>1</td> <td>DATA ENABLE INPUT</td> </tr> <tr> <td>27</td> <td>HSYNC</td> <td>1</td> <td>HORIZONTAL SYNC INPUT</td> </tr> <tr> <td>28</td> <td>VSYNC</td> <td>1</td> <td>VERTICAL SYNC INPUT</td> </tr> </table> <table border="1" data-bbox="582 1220 1061 1310"> <tr> <td>26</td> <td>DEN</td> <td>1</td> <td>DATA ENABLE INPUT</td> <td>DE MODE &amp; SYNC MODE SETTING DE MODE : ONLY DEN AND PIXEL CLOCK IS NECESSARY</td> </tr> <tr> <td>27</td> <td>HSYNC</td> <td>1</td> <td>HORIZONTAL SYNC INPUT</td> <td>SYNC MODE : DEN SHOULD BE CONNECTED TO VSS.</td> </tr> <tr> <td>28</td> <td>VSYNC</td> <td>1</td> <td>VERTICAL SYNC INPUT</td> <td>HSYNC/VSYNC AND PIXEL CLOCK IS NECESSARY.</td> </tr> </table>	PIN NO.	SYMBOL	I/O	FUNCTION	26	DEN	1	DATA ENABLE INPUT	27	HSYNC	1	HORIZONTAL SYNC INPUT	28	VSYNC	1	VERTICAL SYNC INPUT	26	DEN	1	DATA ENABLE INPUT	DE MODE & SYNC MODE SETTING DE MODE : ONLY DEN AND PIXEL CLOCK IS NECESSARY	27	HSYNC	1	HORIZONTAL SYNC INPUT	SYNC MODE : DEN SHOULD BE CONNECTED TO VSS.	28	VSYNC	1	VERTICAL SYNC INPUT	HSYNC/VSYNC AND PIXEL CLOCK IS NECESSARY.
	PIN NO.	SYMBOL	I/O	FUNCTION																													
	26	DEN	1	DATA ENABLE INPUT																													
27	HSYNC	1	HORIZONTAL SYNC INPUT																														
28	VSYNC	1	VERTICAL SYNC INPUT																														
26	DEN	1	DATA ENABLE INPUT	DE MODE & SYNC MODE SETTING DE MODE : ONLY DEN AND PIXEL CLOCK IS NECESSARY																													
27	HSYNC	1	HORIZONTAL SYNC INPUT	SYNC MODE : DEN SHOULD BE CONNECTED TO VSS.																													
28	VSYNC	1	VERTICAL SYNC INPUT	HSYNC/VSYNC AND PIXEL CLOCK IS NECESSARY.																													
13	11.1 POWER SUPPLY FOR LCM  11.2 GAMMA CIRCUIT V4 : 0.8V → 0.2V																																
14	12.1 ELECTRICAL CHARACTERISTICS ADD INPUT VOLTAGE DELETE ABSOLUTE MAXIMUM RATINGS																																
20	13.2 INSPECTION CONDITIONS 30cm~40c → 30cm~40cm 13.2.4 INSPECTION METHOD (b)AQL : MAJOR DEFECT : AQL 0.65% → AQL 0.65 MINOR DEFECT : AQL 1.0% → AQL 1.0																																
28	13.4.1 STANDARD SPECIFICATIONS FOR RELIABILITY OF LCD MODULE <table border="1" data-bbox="630 1803 1029 1915"> <tr> <th>NO</th> <th>ITEM</th> <th>DESCRIPTION</th> </tr> <tr> <td>5</td> <td>High temp / humidity test</td> <td>The sample should be allowed to stand at 60°C , 90% RH 240 hrs</td> </tr> <tr> <td>6</td> <td>Thermal shock (not operated)</td> <td>The sample should be allowed to stand the following 200 cycles of operation: 25°C for 30 minutes - +70°C for 30 minutes</td> </tr> <tr> <td>7</td> <td>ESD (Electrostatic Discharge)</td> <td>AIR DISCHARGE ± 4KV CONTACT DISCHARGE ± 2KV</td> </tr> </table> <table border="1" data-bbox="630 1915 1029 2049"> <tr> <th>NO</th> <th>ITEM</th> <th>DESCRIPTION</th> </tr> <tr> <td>5</td> <td>High temp / humidity test storage</td> <td>The sample should be allowed to stand at 60°C , 90% RH 240 hrs</td> </tr> <tr> <td>6</td> <td>Thermal shock (not operated)</td> <td>The sample should be allowed to stand the following 10 cycles of operation: 40°C for 30 minutes - +80°C for 30 minutes</td> </tr> <tr> <td>7</td> <td>ESD (Electrostatic Discharge) (not operated)</td> <td>AIR DISCHARGE ± 12KV CONTACT DISCHARGE ± 8KV</td> </tr> </table>	NO	ITEM	DESCRIPTION	5	High temp / humidity test	The sample should be allowed to stand at 60°C , 90% RH 240 hrs	6	Thermal shock (not operated)	The sample should be allowed to stand the following 200 cycles of operation: 25°C for 30 minutes - +70°C for 30 minutes	7	ESD (Electrostatic Discharge)	AIR DISCHARGE ± 4KV CONTACT DISCHARGE ± 2KV	NO	ITEM	DESCRIPTION	5	High temp / humidity test storage	The sample should be allowed to stand at 60°C , 90% RH 240 hrs	6	Thermal shock (not operated)	The sample should be allowed to stand the following 10 cycles of operation: 40°C for 30 minutes - +80°C for 30 minutes	7	ESD (Electrostatic Discharge) (not operated)	AIR DISCHARGE ± 12KV CONTACT DISCHARGE ± 8KV								
NO	ITEM	DESCRIPTION																															
5	High temp / humidity test	The sample should be allowed to stand at 60°C , 90% RH 240 hrs																															
6	Thermal shock (not operated)	The sample should be allowed to stand the following 200 cycles of operation: 25°C for 30 minutes - +70°C for 30 minutes																															
7	ESD (Electrostatic Discharge)	AIR DISCHARGE ± 4KV CONTACT DISCHARGE ± 2KV																															
NO	ITEM	DESCRIPTION																															
5	High temp / humidity test storage	The sample should be allowed to stand at 60°C , 90% RH 240 hrs																															
6	Thermal shock (not operated)	The sample should be allowed to stand the following 10 cycles of operation: 40°C for 30 minutes - +80°C for 30 minutes																															
7	ESD (Electrostatic Discharge) (not operated)	AIR DISCHARGE ± 12KV CONTACT DISCHARGE ± 8KV																															
30	ADD 13.6.5																																

TABLE OF CONTENTS

NO.	ITEM	PAGE
1.	GENERAL SPECIFICATIONS -----	1
2.	MECHANICAL SPECIFICATIONS -----	1
3.	ABSOLUTE MAXIMUM RATINGS -----	2
4.	ELECTRICAL CHARACTERISTICS -----	3
5.	TIMING CHART -----	4 , 5
6.	OPTICAL CHARACTERISTICS -----	6 , 7
7.	OUTLINE DIMENSIONS -----	8
8.	BLOCK DIAGRAM -----	9
9.	DETAIL DRAWING OF DOT MATRIX -----	10
10.	INTERFACE SIGNAL -----	11 , 12
11.	POWER SUPPLY -----	13
12.	TOUCH PANEL SPECIFICATION -----	14 ~ 19
13.	INSPECTION CRITERION -----	20 ~ 30

1. GENERAL SPECIFICATIONS

1.1 APPLICATION NOTES FOR CONTROLLER/DRIVER

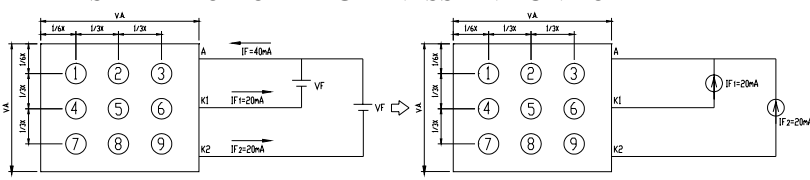
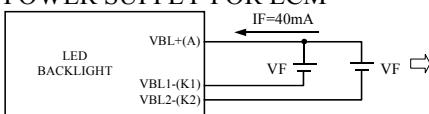
PLEASE REFER TO :

HIMAX HX8250

HIMAX HX8678

1.2 MATERIAL SAFETY DESCRIPTION

ASSEMBLIES SHALL COMPLY WITH EUROPEAN ROHS REQUIREMENTS, INCLUDING PROHIBITED MATERIALS/COMPONENTS CONTAINING LEAD, MERCURY, CADMIUM, HEXAVALENT CHROMIUM, POLYBROMINATED BIPHENYLS (PBB) AND POLYBROMINATED DIPHENYL ETHERS (PBDE)

2. MECHANICAL SPECIFICATIONS

- (1) DISPLAY SIZE (inch) ----- 5.7 inch
- (2) NUMBER OF DOTS ----- 640W \* (RGB) \* 480H DOTS
- (3) MODULE SIZE ----- 147.6W \* 100.0H \*7.5D mm  
(WITHOUT FPC)
- (4) EFFECTIVE AREA ----- 117.2W \* 88.4H mm (T/P)
- (5) ACTIVE AREA ----- 116.2W \* 87.4H mm (T/P)  
115.2W \* 86.4H mm (LCD)
- (6) DOT SIZE ----- 0.06W \* 0.18H mm
- (7) PIXEL SIZE ----- 0.18W \* 0.18H mm
- (8) LCD TYPE ----- TFT , TRANSMISSIVE
- (9) COLOR ----- 16.7M (24BIT)
- (10) VIEWING DIRECTION ----- 12 O'CLOCK
- (11) BACK LIGHT ----- LED , COLOR : WHITE
- (12) INTERFACE MODE ----- RGB, 24 BIT, PARALLEL  
(DE, SYNC MODE)

### 3. ABSOLUTE MAXIMUM RATINGS

#### 3.1 ELECTRICAL ABSOLUTE MAXIMUM RATINGS.

VSS=VSSA=0V

PARAMETER	SYMBOL	MIN.	MAX.	UNIT	REMARK
POWER VOLTAGE	VCC	-0.3	+7.0	V	
	VDDA	-0.3	+13.5	V	
	VGH	-0.3	+42	V	
	VGL	VGH-42	+0.3	V	
INPUT SIGNAL VOLTAGE	Vi	- 0.3	VCC+0.3	V	
LED BACKLIGHT DISSIPATION	PD	—	1.28	W	
LED BACKLIGHT CURRENT	IF	—	0.06	A	
LED BACKLIGHT REVERSE VOLTAGE	VR	—	45	V	

#### 3.2 ENVIRONMENTAL ABSOLUTE MAXIMUM RATINGS

I T E M	OPERATING		STORAGE		REMARK
	MIN.	MAX.	MIN.	MAX.	
AMBIENT TEMPERATURE	- 1 0 °C	6 0 °C	- 2 0 °C	7 0 °C	NOTE ( 1 ) , ( 2 )
HUMIDITY	NOTE ( 3 )		NOTE ( 3 )		WITHOUT CONDENSATION
VIBRATION	—	3.92 m/s <sup>2</sup> ( 0.4 G )	—	19.6 m/s <sup>2</sup> ( 2.0 G )	5~20Hz, 1HR 20~500Hz(20Hz), 1HR 20~500Hz(500Hz), 1HR X, Y, Z, TOTAL 3HR
SHOCK	—	58.8 m/s <sup>2</sup> ( 6 G )	—	980 m/s <sup>2</sup> ( 100 G )	10 m SECONDS XYZ DIRECTIONS 1 TIME EACH
CORROSIVE GAS	NOT ACCEPTABLE		NOT ACCEPTABLE		

NOTE ( 1 ) : Ta AT -30°C : 48HR MAX.  
80°C : 168HR MAX.

NOTE ( 2 ) : BACKGROUND COLOR CHANGES SLIGHTLY DEPENDING ON AMBIENT TEMPERATURE  
THIS PHENOMENON IS REVERSIBLE.

NOTE ( 3 ) : Ta ≤ 60°C : 90%RH MAX (96HRS MAX).  
Ta > 60°C : ABSOLUTE HUMIDITY MUST BE LOWER THAN THE HUMIDITY  
OF 90%RH AT 60°C(96HRS MAX).

4. ELECTRICAL CHARACTERISTICS

Ta = 25 °C

PARAMETER	SYMBOL	CONDITION	MIN.	TYP.	MAX.	UNIT	REMARK
DIGITAL POWER SUPPLY	VCC	—	2.7	3.3	3.6	V	
DIGITAL OPERATING CURRENT	ICC	H LEVEL	—	8	11	mA	
ANALOG POWER SUPPLY	VDDA	L LEVEL	—	11.6	13.5	V	
ANALOG OPERATING CURRENT	IDDA	—	—	17	20	mA	
GATE ON POWER	VGH	H LEVEL	15.5	16	16.5	V	
GATE OFF POWER	VGL	L LEVEL	-7.5	-7	-6.5	V	
VCOM VOLTAGE	VCOM	—	—	3	3.5	V	
INPUT GAMMA VOLTAGE	V1~V4	—	0.2	—	10	V	
FRAME FREQUENCY	fFRAME	—	50	60	72	Hz	
FORWARD VOLTAGE	V <sub>F</sub>	I <sub>F</sub> =40mA	28	30	32	V	NOTE(1)
LED LIFE TIME	—	—	30000	40000	—	hr	

NOTE (1) : INTERNAL CIRCUIT DIAGRAM OF BACKLIGHT

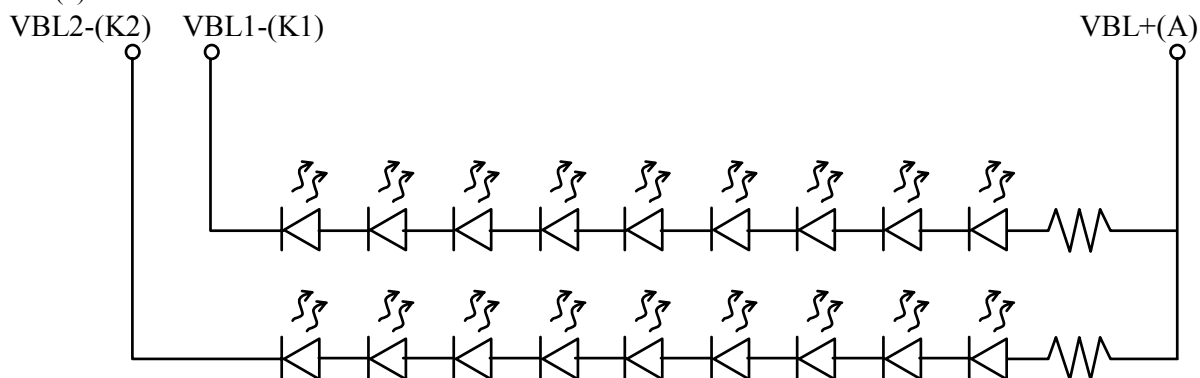

NOTE (2) : AMBIENT TEMP. VS. ALLOWABLE FORWARD CURRENT. (PER LED)

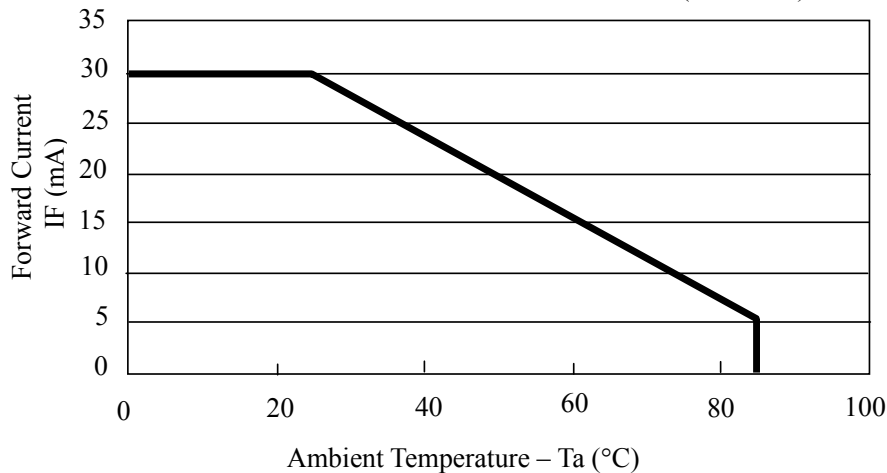

5. TIMING CHART

5.1 DIGITAL PARALLEL RGB INTERFACE (SYNC MODE)

PARAMETER	SYMBOL	SPEC.			UNIT
		MIN.	TYP.	MAX.	
DCLK FREQUENCY	$F_{CPH}$	22.66	25.175	27.69	MHZ
DCLK PERIOD	$T_{CPH}$	36.11	39.7	44.13	ns
DCLK PULSE DUTY	$T_{CWH}$	40	50	60	%
HSYNC PERIOD	$T_H$	750	800	850	$T_{CPH}$
HSYNC PULSE WIDTH	$T_{WH}$	5	30	—	$T_{CPH}$
HSYNC-FIRST HORIZONTAL DATA TIME	$T_{HS}$	112	144	175	$T_{CPH}$
HORIZONTAL ACTIVE DATA AREA	$T_{HA}$	—	640	—	$T_{CPH}$
VSYNC PULSE WIDTH	$T_{WV}$	1	3	5	$T_H$
FIRST LINE DATA INPUT TIME	$T_{STV}$	—	35	—	$T_H$
VSYNC PERIOD	$T_V$	515	525	535	$T_H$

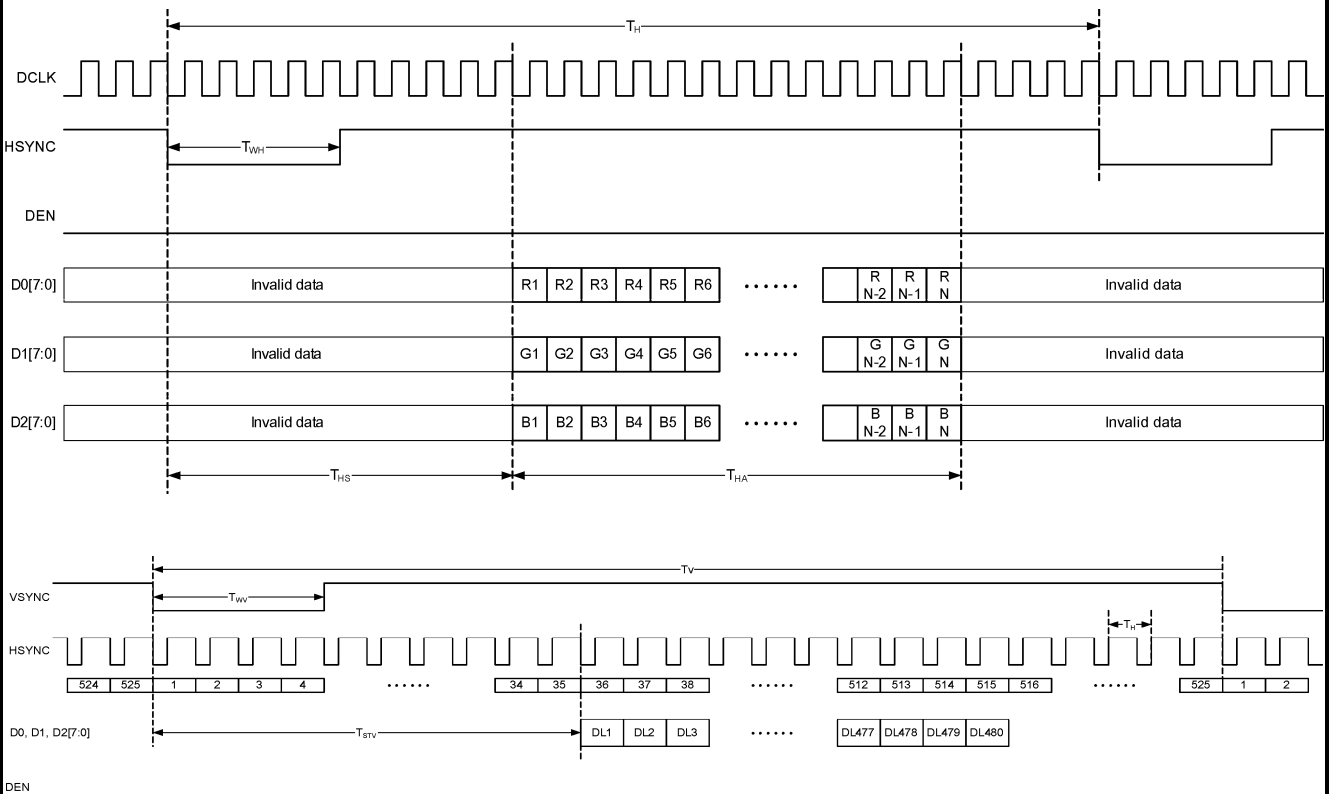

5.2 DIGITAL PARALLEL RGB INTERFACE (DE MODE)

PARAMETER	SYMBOL	SPEC.			UNIT
		MIN.	TYP.	MAX.	
DCLK FREQUENCY	$F_{CPH}$	22.66	25.175	27.69	MHZ
DCLK PERIOD	$T_{CPH}$	36.11	39.7	44.13	ns
DCLK PULSE DUTY	$T_{CWH}$	40	50	60	%
DEN PERIOD	$T_{DEN}$	750	800	850	$T_{CPH}$
DEN PULSE WIDTH	$T_{EP}$	—	640	—	$T_{CPH}$
DEN FRAME ACTIVE TIME	$T_{DEA}$	—	480	—	$T_H$
DEN FRAME BLANKING TIME	$T_{DEB}$	10	45	110	$T_H$

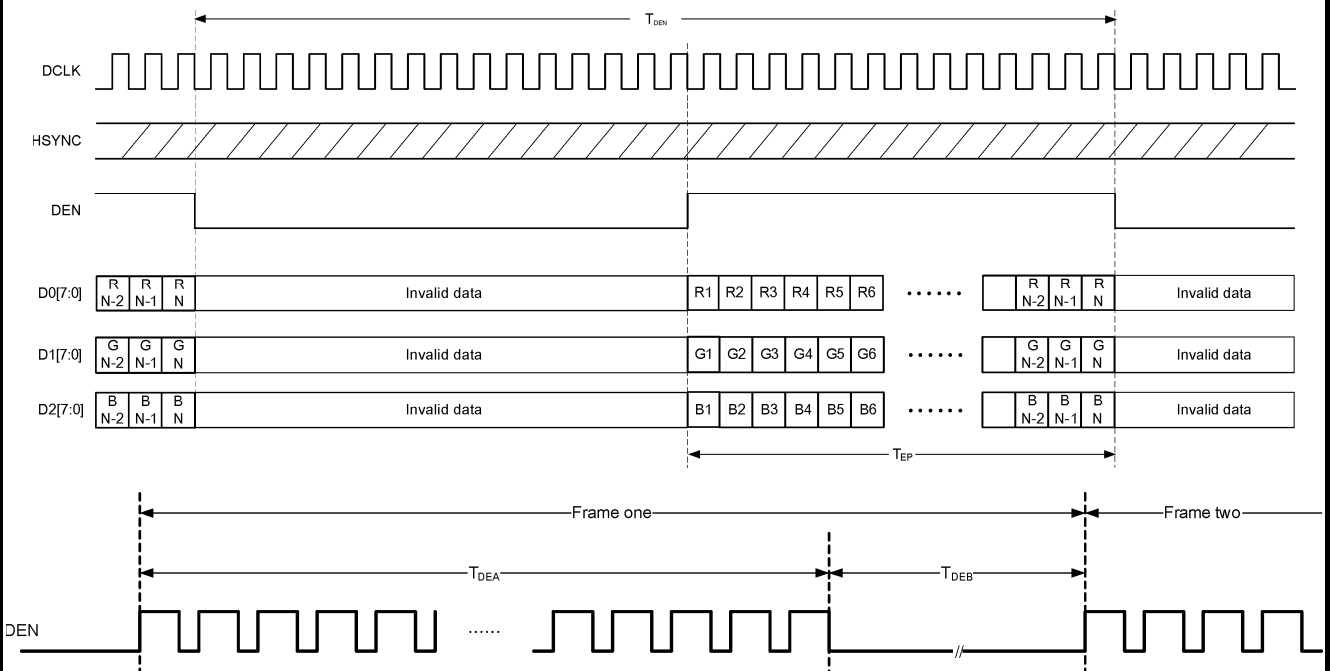

5.3 SPI TIMING CHARACTERISTICS

PARAMETER	SYMBOL	SPEC.			UNIT
		MIN.	TYP.	MAX.	
SPCK PERIOD	$T_{CK}$	60	—	—	ns
SPCK HIGH WIDTH	$T_{CKH}$	30	—	—	ns
SPCK LOW WIDTH	$T_{CKL}$	30	—	—	ns
DATA SETUP TIME	$T_{SU1}$	12	—	—	ns
DATA HOLD TIME	$T_{HD1}$	12	—	—	ns
SPENA TO SPCK SETUP TIME	$T_{CS}$	20	—	—	ns
SPENA TO SPDA HOLD TIME	$T_{CE}$	20	—	—	ns
SPENA HIGH PULSE WIDTH	$T_{CD}$	50	—	—	ns

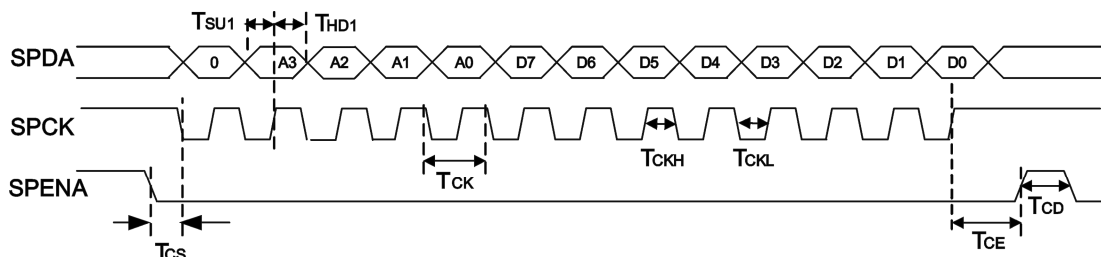

6. OPTICAL CHARACTERISTICS (NOTE 1)  
6.1 OPTICAL CHARACTERISTICS

Ta = 25 ± 2 °C

I T E M		SYMBOL	CONDITION	MIN.	TYP.	MAX.	UNIT	REMARK	
VIEWING ANGLE		$\theta_{y+}$	CR ≥ 10	$\theta_x=0^\circ$	50	55	—	deg.	(2) (3)
		$\theta_{y-}$			47	52	—		
		$\theta_{x+}$	$\theta_y=0^\circ$	60	65	—			
		$\theta_{x-}$		60	65	—			
CONTRAST RATIO		CR	$\theta_x=0^\circ, \theta_y=0^\circ$	300	350	—	—	(3)	
RESPONSE TIME		t r ( rise )	$\theta_x=0^\circ, \theta_y=0^\circ$	—	15	30	msec	(4)	
		t f ( fall )		—	35	50			
THE BRIGHTNESS OF MODULE		B	$\theta_x=0^\circ, \theta_y=0^\circ$ IF=40mA	350	400	—	cd/m <sup>2</sup>	(5)	
COLOR OF CIE COORDINATE	WHITE	x	$\theta_x=0^\circ, \theta_y=0^\circ$ IF=40mA NTSC:50%	0.26	0.31	0.36	—	(6)	
		y		0.30	0.35	0.40			
	RED	x		0.56	0.61	0.66	—		
		y		0.31	0.36	0.41			
	GREEN	x		0.28	0.33	0.38	—		
		y		0.51	0.56	0.61			
	BLUE	x		0.09	0.14	0.19	—		
		y		0.07	0.12	0.17			
THE UNIFORMITY OF MODULE		—	—	75	80	—	%	—	

NOTE (1) : TEST EQUIPMENT SETUP :

AFTER STABILIZING AND LEAVING THE PANEL ALONE AT A GIVEN TEMPERATURE FOR 30 MINUTES, THE MEASUREMENT SHOULD BE EXECUTED. MEASUREMENT SHOULD BE EXECUTED IN A STABLE, WINDLESS, AND DARK ROOM. OPTICAL SPECIFICATIONS ARE MEASURED BY TOPCON BM-7 (FAST) WITH A VIEWING ANGLE OF 1° AT A DISTANCE OF 50cm AND NORMAL DIRECTION.

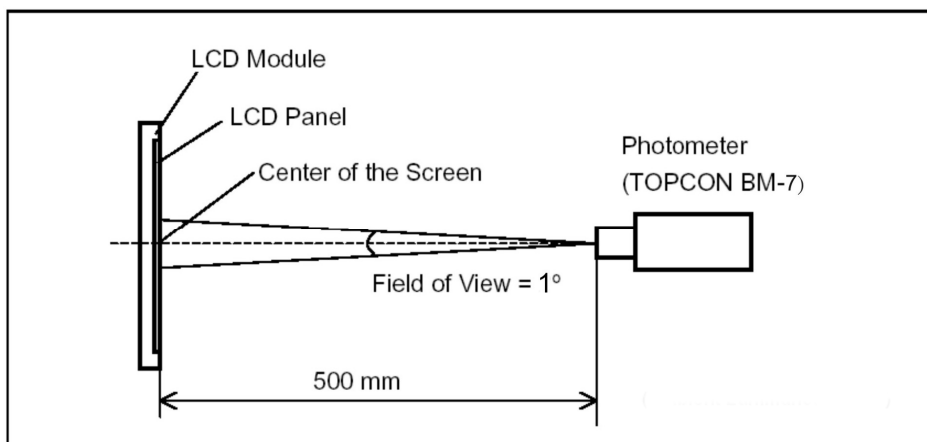

NOTE (2) : DEFINITION OF VIEWING ANGLE :

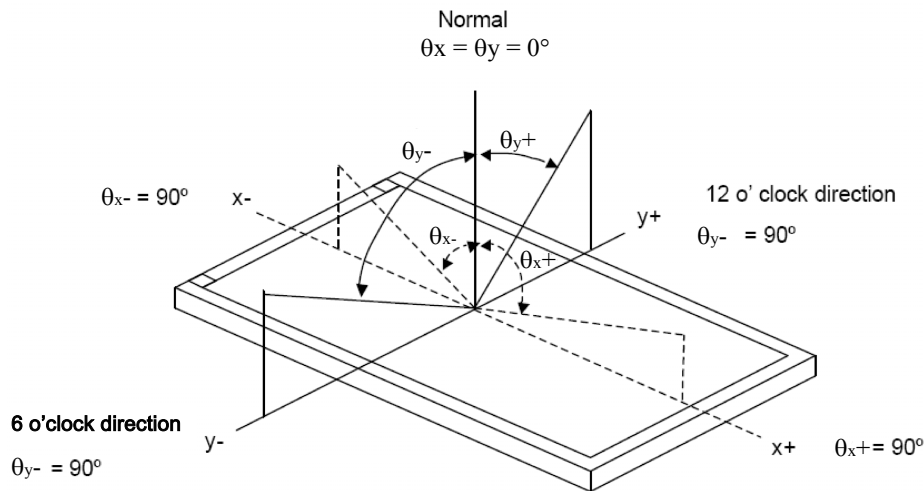

NOTE (3) : DEFINITION OF CONTRAST RATIO :

$$\text{CONTRAST RATIO (CR)} = \frac{\text{BRIGHTNESS MEASURED WHEN LCD IS AT "WHITE STATE"}}{\text{BRIGHTNESS MEASURED WHEN LCD IS AT "BLACK STATE"}}$$

NOTE (4) : DEFINITION OF RESPONSE TIME : TR AND TF

THE FIGURE BELOW IS THE OUTPUT SIGNAL OF THE PHOTO DETECTOR.

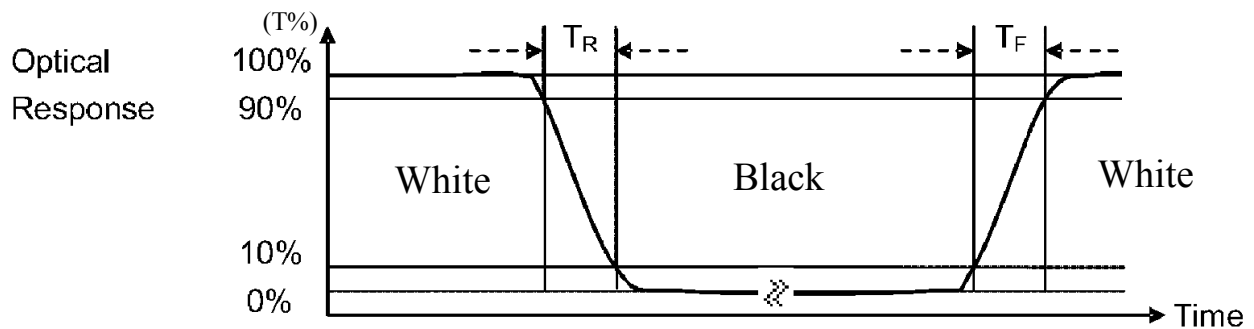

NOTE (5) : BRIGHTNESS MEASURED WHEN LCD IS AT "WHITE STATE"

NOTE (6) : THE 100% TRANSMISSION IS DEFINED AS THE TRANSMISSION OF LCD PANEL WHEN ALL THE INPUT TERMINALS OF MODULE ARE ELECTRICALLY OPENED.

### 6.2 THE TEST METHOD OF BRIGHTNESS AND UNIFORMITY

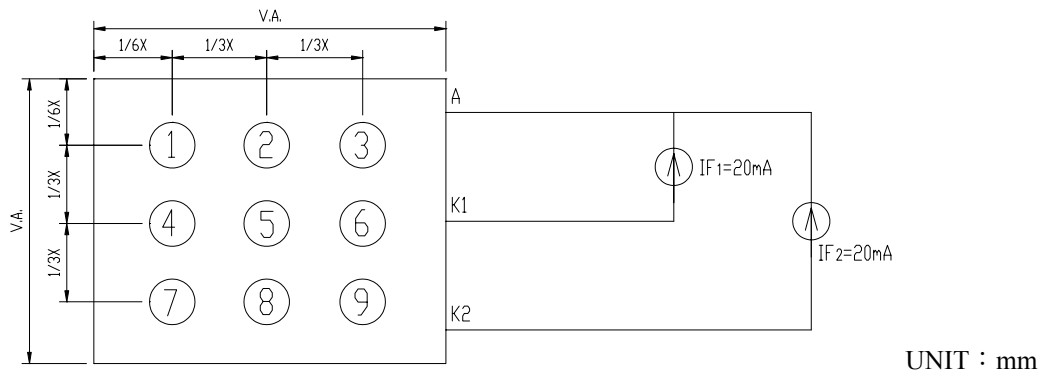

### 6.3 THE CALCULATING METHOD OF UNIFORMITY

$$\text{UNIFORMITY} = \left[ 1 - \frac{\text{MAXIMUM BRIGHTNESS} - \text{MINIMUM BRIGHTNESS}}{\text{AVERAGE BRIGHTNESS}} \right] \times 100\%$$

MODEL NO. ET057005DHU	VERSION 2	PAGE 8
--------------------------	--------------	-----------

7. OUTLINE DIMENSIONS

△Best Contrast but with Gray Level Inversion  
VIEWING DIRECTION

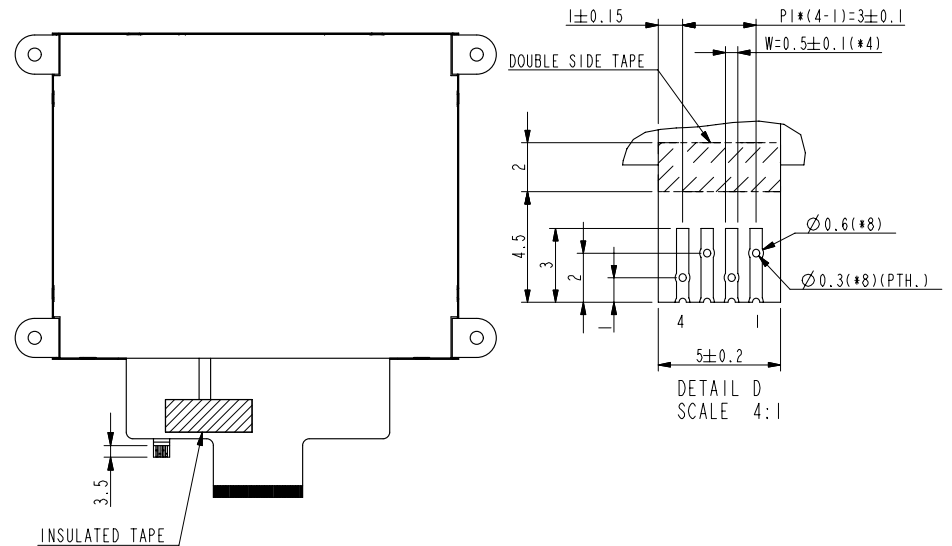
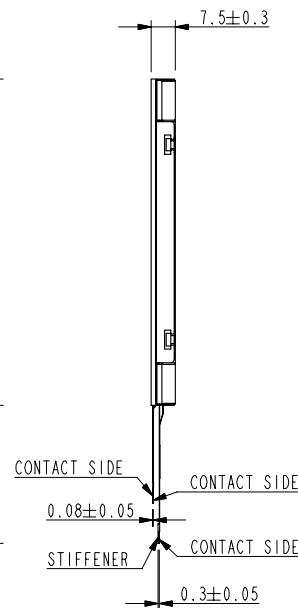
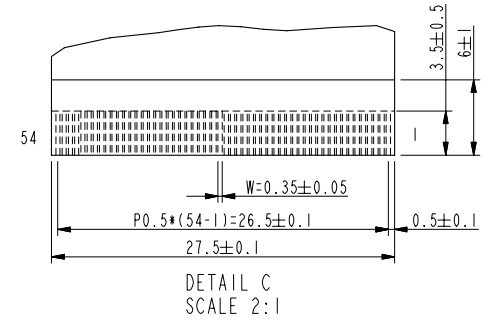
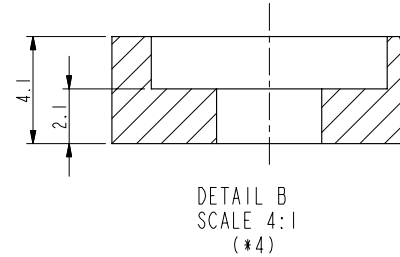
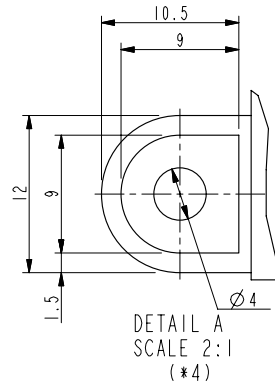
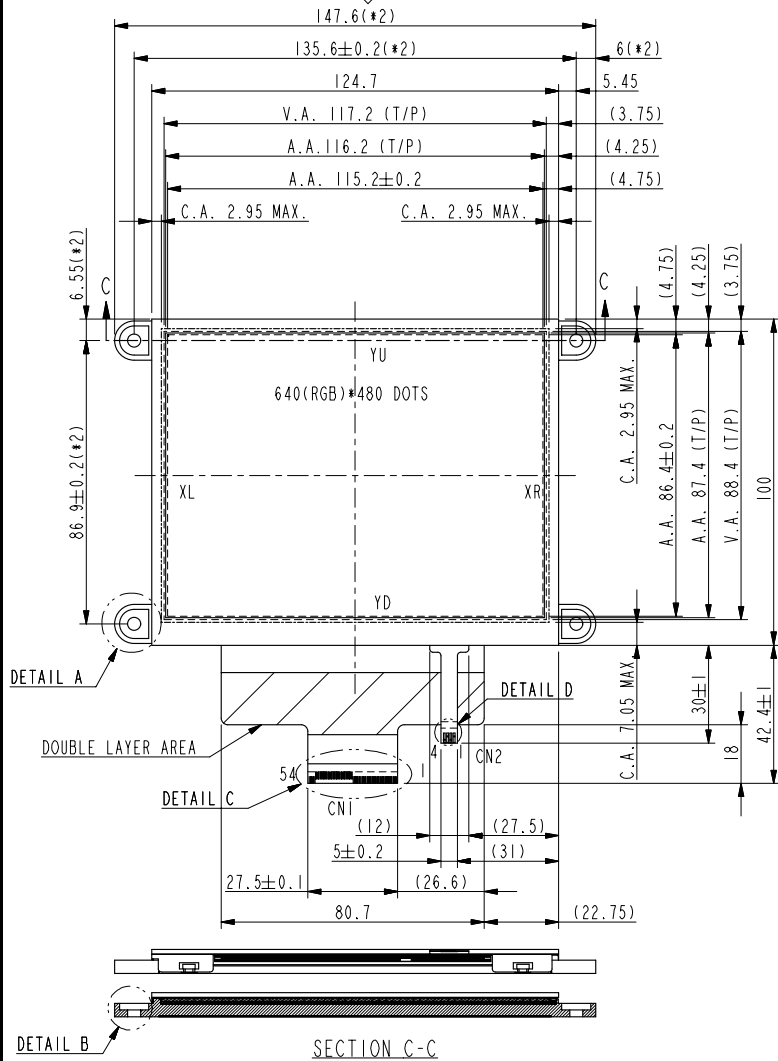

UNIT : mm  
SCALE : NTS  
NOT SPECIFIED TOLERANCE IS ± 0.5  
NOTE : MARK △ MODIFY (NUMBER NOTE MODIFY VERSION)

8. BLOCK DIAGRAM

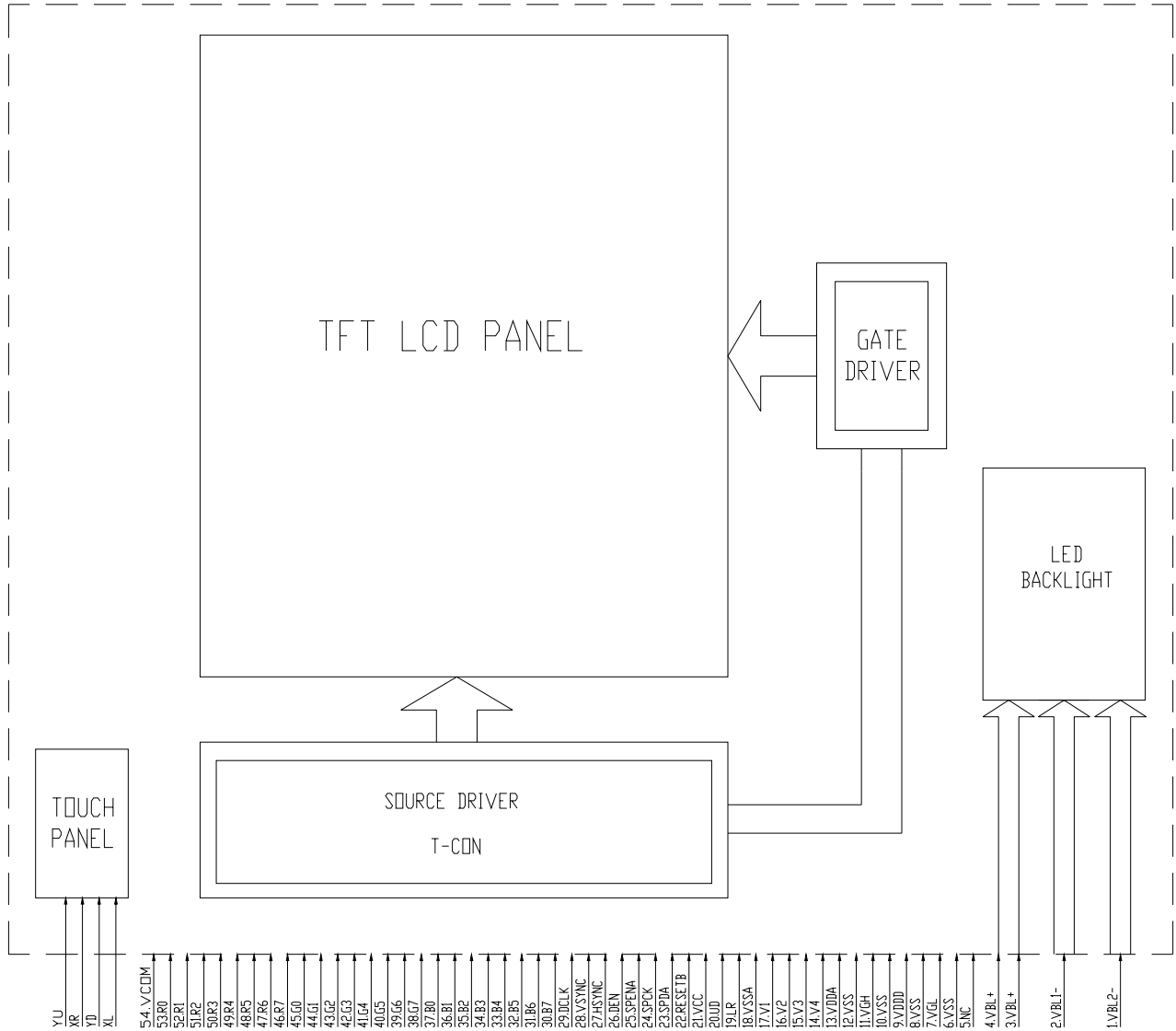

9. DETAIL DRAWING OF DOT MATRIX

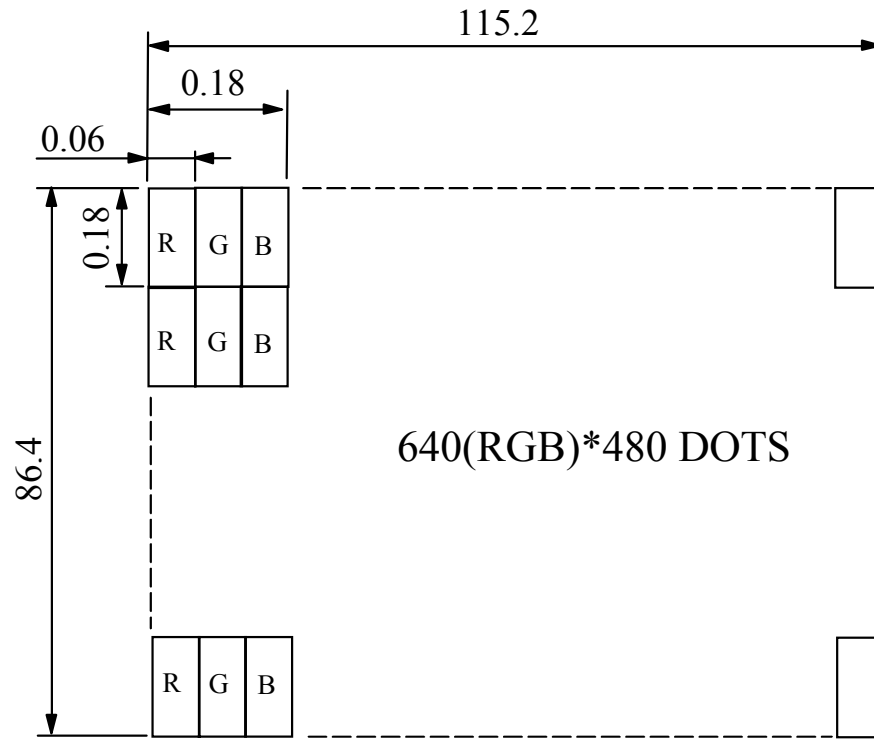

UNIT : mm  
SCALE : NTS  
NOT SPECIFIED TOLERANCE IS  $\pm 0.1$   
DOTS MATRIX TOLERANCE IS  $\pm 0.01$

10. INTERFACE SIGNALS

PIN NO	SYMBOL	I/O	FUNCTION	
1	VBL2-	P	BACKLIGHT LED GROUND (K2)	
2	VBL1-	P	BACKLIGHT LED GROUND (K1)	
3	VBL+	P	BACKLIGHT LED POWER (A)	
4	VBL+	P	BACKLIGHT LED POWER (A)	
5	NC	—	NOT USE	
6	VSS	P	GROUND	
7	VGL	P	GATE OFF POWER	
8	VSS	P	GROUND	
9	VCC	P	DIGITAL POWER	
10	VSS	P	GROUND	
11	VGH	P	GATE ON POWER	
12	VSS	P	GROUND	
13	VDDA	P	ANALOG POWER	
14	V4	P	GAMMA CORRECTION VOLTAGE INPUT PINS	
15	V3	P	GAMMA CORRECTION VOLTAGE INPUT PINS	
16	V2	P	GAMMA CORRECTION VOLTAGE INPUT PINS	
17	V1	P	GAMMA CORRECTION VOLTAGE INPUT PINS	
18	VSSA	P	GROUND	
19	LR	I	LR=H:STH→S01→ ---- → S0960 → STHO LR=L:STH→S960→ ---- → S01 → STHO	
20	UD	I	UP/DOWN SCAN SETTING UD=H, REVERSE SCAN UD=L, NORMAL SCAN	
21	VCC	P	DIGITAL POWER	
22	RESETB	I	HARDWARE RESET	
23	SPDA	I	SPI INTERFACE DATA. DEFAULT PULL HIGH	
24	SPCK	I	SPI INTERFACE DATA CLOCK. DEFAULT PULL HIGH	
25	SPENA	I	SPI INTERFACE DATA ENABLE SIGNAL. DEFAULT PULL HIGH	
26	DEN	I	DATA ENABLE INPUT	DE MODE & SYNC MODE SETTING DE MODE : ONLY DEN AND PIXEL CLOCK IS NECESSARY. SYNC MODE : DEN SHOULD BE CONNECTED TO VSS. HSYNC/VSYNC AND PIXEL CLOCK IS NECESSARY.
27	HSYNC	I	HORIZONTAL SYNC INPUT	
28	VSYNC	I	VERTICAL SYNC INPUT	
29	DCLK	I	DOT DATA COLOCK	
30	B7	I	BLUE DATA BIT 7	
31	B6	I	BLUE DATA BIT 6	

PIN NO	SYMBOL	I/O	FUNCTION
32	B5	I	BLUE DATA BIT 5
33	B4	I	BLUE DATA BIT 4
34	B3	I	BLUE DATA BIT 3
35	B2	I	BLUE DATA BIT 2
36	B1	I	BLUE DATA BIT 1
37	B0	I	BLUE DATA BIT 0
38	G7	I	GREEN DATA BIT 7
39	G6	I	GREEN DATA BIT 6
40	G5	I	GREEN DATA BIT 5
41	G4	I	GREEN DATA BIT 4
42	G3	I	GREEN DATA BIT 3
43	G2	I	GREEN DATA BIT 2
44	G1	I	GREEN DATA BIT 1
45	G0	I	GREEN DATA BIT 0
46	R7	I	RED DATA BIT 7
47	R6	I	RED DATA BIT 6
48	R5	I	RED DATA BIT 5
49	R4	I	RED DATA BIT 4
50	R3	I	RED DATA BIT 3
51	R2	I	RED DATA BIT 2
52	R1	I	RED DATA BIT 1
53	R0	I	RED DATA BIT 0
54	VCOM	P	VCOM VOLTAGE

T/P INTERFACE

NO	SYMBOL	FUNCTION
1	YU	TOP PANEL
2	XR	RIGHT PANEL
3	YD	BOTTOM PANEL
4	XL	LEFT PANEL

1 1 . POWER SUPPLY

1 1 .1 POWER SUPPLY FOR LCM

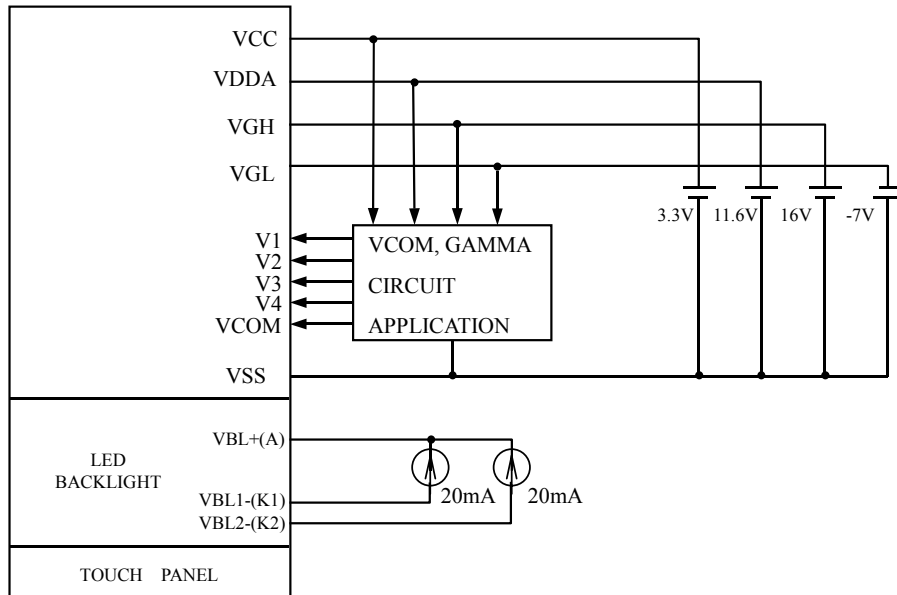

1 1 .2 GAMMA CIRCUIT

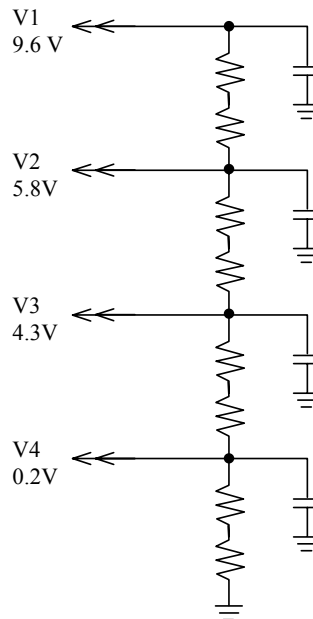

1 1 .3 POWER SEQUENCE

THE LCD PANEL ADOPTS HIGH VOLTAGE DRIVER ICs, SO IT COULD BE PERMANENTLY DAMAGED IF A WRONG POWER ON/OFF SEQUENCE IS USED. WHEN POWERING ON THE LCD, VCC SHOULD GO UP FIRSTLY, AND THEN TURN ON VGL AND VDD, AND FINALLY VGH. TURN OFF THE LCD PANEL WITH REVERSED ORDER OR SHUT OFF ALL THE POWER SUPPLIES SIMULTANEOUSLY.

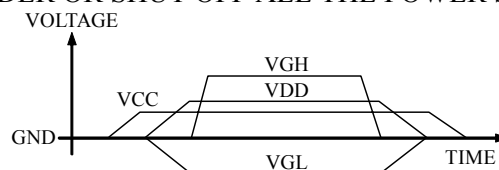

12. TOUCH PANEL SPECIFICATION  
12.1 ELECTRICAL CHARACTERISTICS

Ta = 25°C

ITEM	CONDITION	SPEC.	UNIT
LINEARITY	—	≤ 1.5	%
TRANSMISSION	ASTM D1003	80 OR MORE	%
ON LOAD	POLYACETAL PEN INPUT	15 ~ 80	g
TERMINAL RESISTANCE	X AXIS	400 ~ 1000	Ω
	Y AXIS	200 ~ 700	
INSULATION RESISTANCE	DC25V	≥ 10	MΩ
INPUT VOLTAGE	—	5(TYP.)	V

12.2 PRECAUTIONS IN USE OF TOUCH PANEL

12.2.1 PURPOSE :

IN ORDER TO PREVENT ACCIDENTAL USE AND PERFORMANCE DETERIORATION, PLEASE KEEP THE FOLLOWING PRECAUTIONS AND INHIBITED POINTS.

12.2.2 ITEM AND ILLUSTRATION :

( 1 ) STRUCTURE, AREA DEFINITION

THE STRUCTURE AND THE PERFORMANCE GUARANTEED AREA OF THIS TOUCH PANEL ARE DEFINED BELOW :

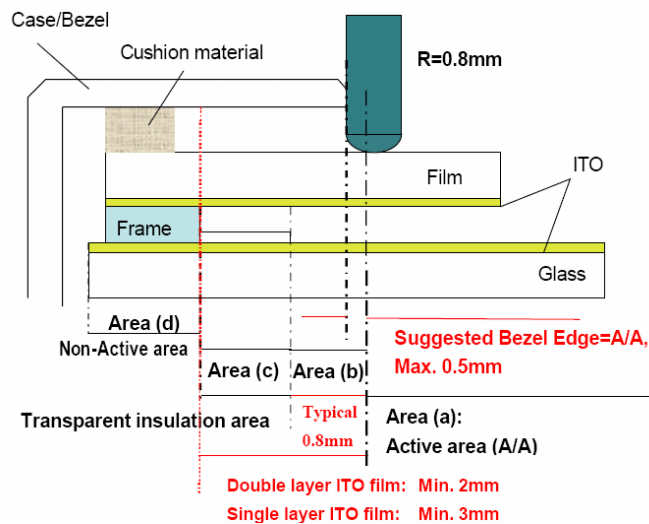

THE ABOVE FIGURE IS OUR DESIGN RULE OF TOUCH PANEL. IF IT CANNOT MEET YOUR REQUIREMENT, PLEASE CONTACT WITH OUR ENGINEERS FOR FURTHER DISCUSSION.

ABOVE FIGURE ILLUSTRATES THE RECOMMENDED BEZEL AND CUSHION DESIGN. IN ORDER TO PREVENT UNUSUAL PERFORMANCE DEGRADATION AND MALFUNCTION OF A TOUCH PANEL, PLEASE CARRY OUT THE SET CASE DESIGNING AND A TOUCH PANEL ASSEMBLING METHOD AFTER SURELY CONSIDERING THE DEFINITION OF EACH AREA ILLUSTRATED IN ABOVE FIGURE.

AREA(a) : ACTIVE AREA

THE ACTIVE AREA IS GUARANTEED THE POSITION DATA DETECTABLE PRECISION, OPERATION FORCE AND OTHER OPERATIONS. IT IS STRONGLY RECOMMENDED TO PLACE THE OPERATION BUTTON OR MENU KEYS WITHIN THE ACTIVE AREA. DUE TO STRUCTURE, THE ACTIVE AREA IS LESS DURABLE AT THE EDGE OR CLOSE TO THE EDGE.

AREA(b) : OPERATION NON-GUARANTEED AREA

THIS AREA DOES NOT GUARANTEE A TOUCH PANEL OPERATION AND ITS FUNCTION. WHEN THIS AREA IS PRESSED, TOUCH PANEL SHOWS DEGRADATION OF ITS PERFORMANCE AND DURABILITY SUCH AS A PEN SLIDING DURABILITY BECOMES ABOUT ONE-TENTH COMPARED WITH THE ACTIVE AREA (AREA-(A) AS GUARANTEED AREA) AND ITS OPERATION FORCE REQUIRES ABOUT DOUBLE. ABOUT 0.5 MM OUTSIDE FROM A BOUNDARY OF THE ACTIVE AREA CORRESPONDS TO THIS AREA.

AREA(c) : PRESSING PROHIBITION AREA

THE AREA WHICH FORBIDS PRESSING, BECAUSE AN EXCESSIVE LOAD IS APPLIED TO A TRANSPARENT ELECTRODE (ITO) AND A SERIOUS DAMAGE IS GIVEN TO A TOUCH PANEL FUNCTION BY PRESSING.

AREA(d) : NON-ACTIVE AREA

THE AREA DOES NOT ACTIVATE EVEN IF PRESSED.

(2) CAUTIONS FOR INSTALLING AND ASSEMBLING

(i) DO NOT GIVE EXCESSIVE STRAIN TO THE PRODUCT.

(ii) FLEXIBLE PATTERN CABLE IS CONNECTED TO THE BODY BY THERMAL PRESSURE METHOD. SO, DO NOT APPLY EXCESSIVE FORCES TO THE FLEXIBLE PATTERN. DO NOT ADD AN EXCESSIVE FORCE TO A FPC(FLEX TAIL) THAT MAKES PEELING OFF OF THE FPC FROM THE PRODUCT. DO NOT FIX, ADHERE OR MOUNT ANY ADDITIONAL GOODS ON THE FPC SUCH AS ADDITIONAL FILM/PLATE ON THE FPC, BECAUSE SUCH ADDITIONAL GOODS WILL APPLY A STRESS AT THE FPC BONDING AREA. IT MAY AFFECT THE CONDUCTIVITY OF FPC WITH TOUCH PANEL.

(iii) IN ORDER NOT TO APPLY LOAD ON THE DISPLAY, PROVIDE A CLEARANCE OF AT LEAST 0.3MM BETWEEN THE PRODUCT AND DISPLAY.

(iv) WE RECOMMEND THE DESIGN OF A CASE OR BEZEL SHOULD COVERS THE BOUNDARY OF THE ACTIVE AREA INSIDE IN ORDER TO PREVENT AN OPERATION AT OUTSIDE OF THE ACTIVE AREA WHICH CAN NOT GUARANTEE THE FUNCTION OR DURABILITY (REFER TO ITEM 5.1.2. STRUCTURE, AREA DEFINITION).

BEZEL'S EDGE PART MAY GUIDE THE PEN SLIDING ON THE SAME POSITION REPEATEDLY. IF THE BEZEL IS PLACED OUTSIDE OF THE ACTIVE AREA, IT MAY CAUSE THE DAMAGE OF THE ITO FILM.

- (v) PRESSING INSIDE OF BOUNDARY OF THE FRAME(PART (A) AS SHOWN IN BELOW) MAY CAUSES FAULT OPERATION, SO PLEASE DESIGN TO AVOID PRESSING OF TOUCH PANEL AT PART (A) SUCH AS HAVING GASKET/CUSHION AT PART (C). PARTICULARLY THE AREA (B) SHALL BE FREE FROM BURR. THE GASKET/CUSHION MATERIAL AT THE PART (C) SHOULD NOT BE EXCEEDED TO INSIDE OF THE BOUNDARY OF THE FRAME.

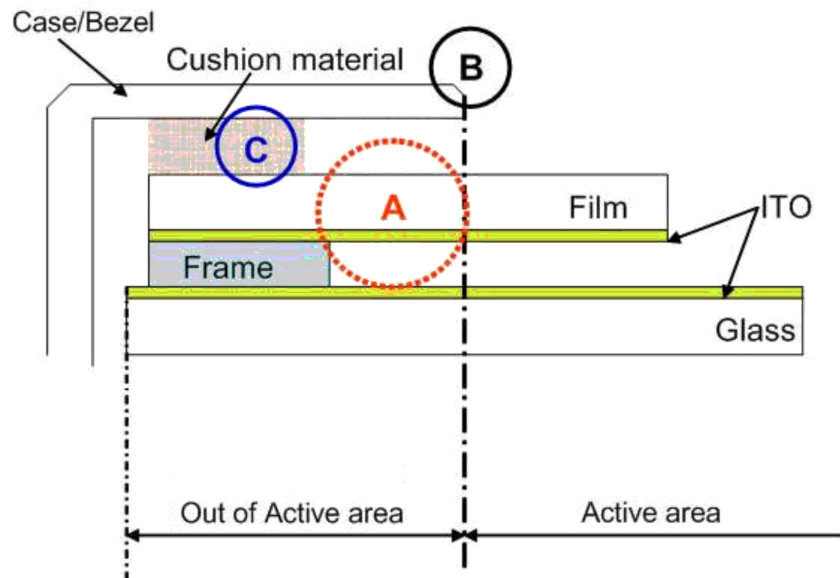

- (vi) TO PREVENT GIVING DISTORTION TO THE FILM OF THE PRODUCT AND PEELING OFF OF THE FILM FROM THE PRODUCT, DO NOT FIX THE FILM AND A SET CASE OR A SHOCK ABSORBING MATERIAL ADHERED TO A SET CASE BY ADHESION.
- (vii) WIPE OFF THE STAIN ON THE PRODUCT BY USING SOFT CLOTH MOISTENED WITH ETHANOL. TAKE CARE NOT TO ALLOW ETHANOL TO SOAK INTO THE JOINT OF UPPER FILM AND BOTTOM GLASS. IT MAY OTHERWISE CAUSE PEELING OR DEFECTIVE OPERATION. DO NOT USE ANY ORGANIC SOLVENT OR DETERGENT OTHER THAN ETHANOL.
- (viii) THE CORNERS OF THE PRODUCT ARE NOT CHAMFERED AND ARE SHARP. WHEN POSITIONING AND FIXING THE PRODUCT ON THE CASE, PROVIDE A ROUND PART ON THE CORNER OF THE CASE SO AS NOT TO APPLY LOAD ON THE CORNER OF THE TRANSPARENT TOUCH PANEL.
- (ix) DO NOT PRESS THE FILM OF THE PRODUCT WHEN THIS PRODUCT IS BUILT INTO A SET.
- (3) CAUTIONS FOR OPERATION
- (i) OPERATE IT WITH A POLYACETAL PEN (TIP R0.8 OR OVER) OR A BELLY OF A FINGER WITHOUT APPLYING EXCESSIVE LOAD. NEVER USE ANY MECHANICAL PENCILS, BALL POINT PENS AND HARD FINGERTIPS WHO'S TIP IS HARD FOR INPUT, OTHERWISE MALFUNCTIONS MAY RESULT.

- (ii) THE INPUT POSITION MAY BE FLUCTUATED A LITTLE THROUGH LONG-TIME USE. IT IS DESIRABLE TO PROVIDE A ZERO-ADJUSTMENT FUNCTION BY USING A CIRCUIT AND SOFTWARE.
- (iii) OPERATION AT THE OUT OF ACTIVE AREA IS OUT OF OUR GUARANTEE. IT CAUSES A SERIOUS DAMAGE OF A TRANSPARENT ELECTRODE. DO NOT OPERATE AT THE OUT OF ACTIVE AREA.
- (iv) IN CASE OF CLEANING THE PART OF THE CASE BOUNDARY OF ACCOMPLISHED SET, USE A SOFT CLOTH WITH A FINGER BERRY OR A COTTON BUD. DO NOT CLEAN WITH A THING OTHER THAN THE FINGER SUCH AS HARD OR SHARP EDGES LIKE A FINGER NAIL ETC. ON THE CLOTH, BECAUSE IT CAUSE TRANSPARENT CONDUCTIVE FILM CRACKS. PLEASE ADVISE THIS PROHIBITION TO YOUR LAST CUSTOMERS.

### 12.3 DURABILITY

#### 12.3.1 STYLUS HITTING :

ONE MILLION TIMES OR OVER  
NO DAMAGE ON FILM SURFACE  
PEN : R8 mm SILICON RUBBER  
LOAD : 250g  
FREQUENCY : 240 times/min  
MEASUREMENT POSITION:  
1 POINT OF TOUCH PANEL ACTIVE AREA  
REPEATED : OVER 1,000,000 TIMES

#### 12.3.2 PEN TOUCH SLIDING DURABILITY :

100,000 TIMES OR OVER  
WRITING WITH R0.8mm PLASTIC STYLUS PEN; WRITING FORCE 150g  
IN ACTIVE AREA.  
SPEED IS 60mm/sec.

#### 12.4 STEEL BALL DROP TEST

BY USING F9mm STEEL BALL FROM THE HEIGHT OF 30cm AND FALLING ON TOUCH PANEL SURFACE, MUST PASS BELOW CONDITIONS :  
APPEARANCE : THE APPEARANCE WITHOUT ANY CHANGE, INCLUDING THE PANEL BROKEN.

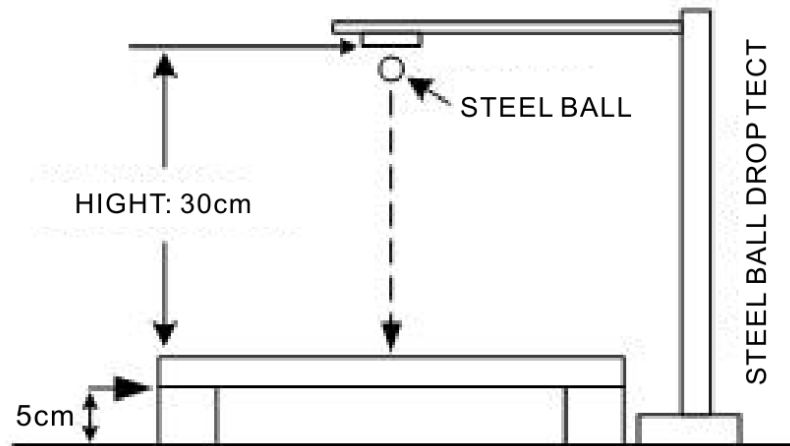

#### 12.5 APPEARANCE INSPECTION

PURPOSE :

TO ESTABLISH APPEARANCE STANDARD AND MAINTAIN PRODUCT QUALITY .

SCOPE :

TOUCH PANEL VIEW AREA WITHIN TOUCH PANEL .

##### 12.5.1 RULE :

INSPECTION CONDITION

(A) ENVIRONMENTAL LUMINANCE : 500 LUX .

(B) DISTANCE BETWEEN HUMAN EYES AND PANEL : 30 CM

(PANEL MUST BE TESTED UNDER LIGHT TRANSPARENT) .

(C) VISUAL ANGEL :  $> 60^\circ$  .

(D) LIGHT SOURCE : FLUORESCENT LIGHT SOURCE .

##### 12.5.2 JUDGE CRITERION :

JUDGEMENT UNDER ABOVE MENTIONED CRITERION (PANEL MUST BE TESTED UNDER LIGHT TRANSPARENT),

TESTING GOODS DEFECT CAN BE VISIBLE WITHIN 10 SECONDS, WHICH WILL BE JUDGED AS MAJOR DEFECTS .

SAMPLING STANDARD :

THE SAMPLING STANDARD WILL BE CONFIRMED BY BOTH OF EDT AND CUSTOMER.

INSPECTION ITEMS	SEPC.	JUDGE CRITERION	OPERATION GUIDELINE
SCRATCH	$W \leq 0.05\text{mm} \ \& \ L \leq 10\text{mm}$	ACCEPTABLE	
	$W > 0.05\text{mm} \ \text{or} \ L > 10\text{mm}$	NOT ACCEPTABLE	
LINEAR FOREIGN OBJECT	$W \leq 0.05\text{mm} \ \& \ L \leq 5\text{mm}$	ACCEPTABLE	
	$W > 0.05\text{mm} \ \text{or} \ L > 5\text{mm}$	NOT ACCEPTABLE	
GRANULAR FOREIGN OBJECT	$D \leq 0.25\text{mm}$	ACCEPTABLE	
	$0.25\text{mm} < D \leq 0.30\text{mm}$	MAX. 2 EA	
	$D > 0.30\text{mm}$	NOT ACCEPTABLE	
PET BUBBLES	$D \leq 0.5\text{mm}$	ACCEPTABLE	
	$D > 0.5\text{mm}$	NOT ACCEPTABLE	
CHIP ON GLASS	CORNER $X \leq 3\text{mm} \ \cdot$ $Y \leq 3\text{mm} \ \cdot$ $Z < t$ $(t = \text{/thickness})$	ACCEPTABLE	
	EDGE $W \leq 3\text{mm} \ \cdot$ $Y \leq 3\text{mm} \ \cdot$ $Z < t$		

### 13 . INSPECTION CRITERION

#### 13.1 APPLICATION

This inspection standard is to be applied to the LCD module delivered from EMERGING DISPLAY TECHNOLOGIES CORP.( E.D.T ) to customers

#### 13.2 INSPECTION CONDITIONS

13.2.1 (1)Observation Distance : 35cm±5cm

(2)View Angle :

Non-operation Condition : ±5°(perpendicular to LCD panel surface)

Operation Condition : ±45° (perpendicular to LCD panel surface)

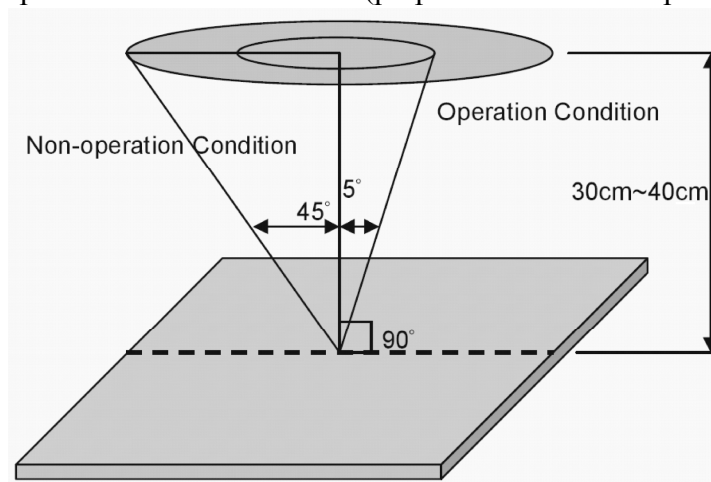

13.2.2 Environment Conditions :

Ambient Temperature		20°C~25°C
Ambient Humidity		65±20%RH
Ambient Illumination	Cosmetic Inspection	More than 600Lux
	Functional Inspection	300~500 Lux

13.2.3 Inspection lot

Quantity per delivery lot for each model

13.2.4 Inspection method

A sampling inspection shall be made according to the following provisions to judge The acceptability

(a)Applicable standard : MIL-STD-105E

Normal inspection, single sampling

Level II

(b)AQL : Major defect : AQL 0.65

Minor defect : AQL 1.0

13.3 INSPECTION STANDARDS

13.3.1 VISUAL DEFECTS CLASSIFICATION

TYPE OF DEFECT	INSPECTION ITEM	DEFECT FEATURE	AQL
MAJOR DEFECT	1.DISPLAY ON	<ul style="list-style-type: none"> <li>• DEFECT TO MISS SPECIFIED DISPLAY FUNCTION, FOR ALL AND SPECIFIED DOTS</li> <li>EX: DISCONNECTION, SHORT CIRCUIT ETC</li> </ul>	0.65
	2.BACKLIGHT	<ul style="list-style-type: none"> <li>• NO LIGHT</li> <li>• FLICKERING AND OTHER ABNORMAL ILLUMINATION</li> </ul>	
	3.DIMENSIONS	<ul style="list-style-type: none"> <li>• SUBJECT TO INDIVIDUAL ACCEPTANCE SPECIFICATIONS</li> </ul>	
MINOR DEFECT	1.DISPLAY ZONE	<ul style="list-style-type: none"> <li>• BLACK/WHITE SPOT</li> <li>• BUBBLES ON POLARIZER</li> <li>• NEWTON RING</li> <li>• BLACK/WHITE LINE</li> <li>• SCRATCH</li> <li>• CONTAMINATION</li> <li>• LEVER COLOR SPREED</li> </ul>	1.0
	2.BEZEL ZONE	<ul style="list-style-type: none"> <li>• STAINS</li> <li>• SCRATCHES</li> <li>• FOREIGN MATTER</li> </ul>	
	3.SOLDERING	<ul style="list-style-type: none"> <li>• INSUFFICIENT SOLDER</li> <li>• SOLDERED IN INCORRECT POSITION</li> <li>• CONVEX SOLDERING SPOT</li> <li>• SOLDER BALLS</li> <li>• SOLDER SCRAPS</li> </ul>	
	4.DISPLAY ON (ALL ON)	<ul style="list-style-type: none"> <li>• LIGHT LINE</li> </ul>	

13.3.2 MODULE DEFECTS CALSSIFICATION

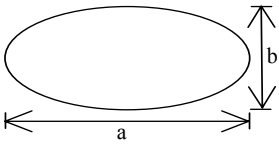
NO.	ITEM	CRITERIA												
1.	DISPLAY ON INSPECTION	(1)INCORRECT PATTERN (2)MISSING SEGMENT (3)DIM SEGMENT (4)OPERATING VOLTAGE BEYOND SPEC												
2.	OVERALL DIMENSIONS	(1)OVERALL DIMENSION BEYOND SPEC												
3.	DOT DEFECT	(1)INSPECTION PATTERN : FULL WHITE,FULL BLACK, RED, GREEN AND BLUE SCREENS. (2) <table border="1" style="margin-left: 40px;"> <thead> <tr> <th>ITEMS</th> <th>ACCEPTABLE COUNT</th> </tr> </thead> <tbody> <tr> <td>BRIGHT DOT</td> <td><math>N \leq 2</math></td> </tr> <tr> <td>DARK DOT</td> <td><math>N \leq 3</math></td> </tr> <tr> <td>TOAL BRIGHT AND DARK DOTS</td> <td><math>N \leq 4</math></td> </tr> </tbody> </table> <p>NOTE : 1.THE DEFINITION OF DOT: THE SIZE OF A DEFECTIVE DOT OVER 1/2 OF WHOLE DOT IS REGARDED AS ONE DEFECTIVE DOT. 2.BRIGHT DOTS: DOTS APPEAR BRIGHT AND UNCHANGED IN SIZE IN WHICH LCD PANEL IS DISPLAYING UNDER BLACK PATTERN. 3.DARK DOT: DOTS APPEAR DARK AND UNCHANGED IN SIZE IN WHICH LCD PANEL IS DISPLAYING UNDER PURE RED, GREEN, BLUE PICTURE.</p>	ITEMS	ACCEPTABLE COUNT	BRIGHT DOT	$N \leq 2$	DARK DOT	$N \leq 3$	TOAL BRIGHT AND DARK DOTS	$N \leq 4$				
ITEMS	ACCEPTABLE COUNT													
BRIGHT DOT	$N \leq 2$													
DARK DOT	$N \leq 3$													
TOAL BRIGHT AND DARK DOTS	$N \leq 4$													
4.	FOREIGN BLACK/ WHITE BRIGHT LINE/ SCRATCH OF VIEWING AREA	<table border="1" style="margin-left: 40px;"> <thead> <tr> <th>LENGTH : L</th> <th>WIDTH : W</th> <th>PERMISSIBLE NO.</th> </tr> </thead> <tbody> <tr> <td><math>L \leq 0.3</math></td> <td><math>W \leq 0.05</math></td> <td>IGNORE</td> </tr> <tr> <td><math>0.3 &lt; L \leq 2.5</math></td> <td><math>0.05 &lt; W \leq 0.1</math></td> <td>4</td> </tr> <tr> <td><math>2.5 &lt; L</math></td> <td><math>0.1 &lt; W</math></td> <td>NONE</td> </tr> </tbody> </table> <p>WIDTH : W mm , LENGH : L mm</p>	LENGTH : L	WIDTH : W	PERMISSIBLE NO.	$L \leq 0.3$	$W \leq 0.05$	IGNORE	$0.3 < L \leq 2.5$	$0.05 < W \leq 0.1$	4	$2.5 < L$	$0.1 < W$	NONE
LENGTH : L	WIDTH : W	PERMISSIBLE NO.												
$L \leq 0.3$	$W \leq 0.05$	IGNORE												
$0.3 < L \leq 2.5$	$0.05 < W \leq 0.1$	4												
$2.5 < L$	$0.1 < W$	NONE												
5.	FOREIGN MATTER \ BLACK SPOTS \ WHITE SPOTS \ DENT (INCLUDING LIGHT LEAKAGE DUE TO POLARIZING PLATES PINHOLES, ETC.)	<table border="1" style="margin-left: 40px;"> <thead> <tr> <th>AVERAGE DIAMETER (mm): D</th> <th>NUMBER OF PIECES PERMITTED</th> </tr> </thead> <tbody> <tr> <td><math>D \leq 0.15</math></td> <td>IGNORE</td> </tr> <tr> <td><math>0.15 &lt; D \leq 0.5</math></td> <td>4</td> </tr> <tr> <td><math>0.5 &lt; D</math></td> <td>NONE</td> </tr> </tbody> </table> <p>Note : Diameter <math>D = (a+b)/2</math></p> 	AVERAGE DIAMETER (mm): D	NUMBER OF PIECES PERMITTED	$D \leq 0.15$	IGNORE	$0.15 < D \leq 0.5$	4	$0.5 < D$	NONE				
AVERAGE DIAMETER (mm): D	NUMBER OF PIECES PERMITTED													
$D \leq 0.15$	IGNORE													
$0.15 < D \leq 0.5$	4													
$0.5 < D$	NONE													

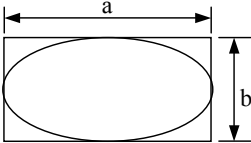
NO.	ITEM	CRITERIA																				
6.	BUBBLES OF POLARIZER /DIRT/CF FAIL /SURFACE STAINS	<table border="1" data-bbox="587 421 1409 770"> <thead> <tr> <th></th> <th>AVERAGE DIAMETER (mm):D</th> <th>NUMBER OF PIECES PERMITTED</th> </tr> </thead> <tbody> <tr> <td rowspan="3">BUBBLE ON THE POLARIZER</td> <td><math>D \leq 0.25</math></td> <td>IGNORE</td> </tr> <tr> <td><math>0.25 &lt; D \leq 0.5</math></td> <td><math>N \leq 5</math></td> </tr> <tr> <td><math>0.5 &lt; D</math></td> <td>NOTE</td> </tr> <tr> <td rowspan="2">SURFACE STATUS</td> <td><math>D &lt; 0.1 \text{ mm}</math></td> <td>IGNORE</td> </tr> <tr> <td><math>0.1 &lt; D \leq 0.3\text{mm}</math></td> <td><math>N \leq 3</math></td> </tr> <tr> <td rowspan="2">CF FAIL / SPOT</td> <td><math>D &lt; 0.1 \text{ mm}</math></td> <td>IGNORE</td> </tr> <tr> <td><math>0.1 &lt; D \leq 0.3\text{mm}</math></td> <td><math>N \leq 3</math></td> </tr> </tbody> </table> <p data-bbox="587 779 1441 1084">NOTE : (1)POLARIZER BUBBLE IS DEFINED AS THE BUBBLE APPEARS ON ACTIVE DISPLAY AREA. THE DEFECT OF POLARIZER BUBBLE SHALL BE IGNORED IF THE POLARIZER BUBBLE APPEARS ON THE OUTSIDE OF ACTIVE DISPLAY AREA. (2)THE EXTRANEOUS SUBSTANCE IS DEFINED AS IT CAN BE OBSERVED WHEN THE MODULE IS POWER ON. (3)THE DEFINITION OF AVERAGE DIAMETER, D IS DEFINED AS FOLLOWING. AVERAGE DIAMETER <math>D=(a+b)/2</math></p> 		AVERAGE DIAMETER (mm):D	NUMBER OF PIECES PERMITTED	BUBBLE ON THE POLARIZER	$D \leq 0.25$	IGNORE	$0.25 < D \leq 0.5$	$N \leq 5$	$0.5 < D$	NOTE	SURFACE STATUS	$D < 0.1 \text{ mm}$	IGNORE	$0.1 < D \leq 0.3\text{mm}$	$N \leq 3$	CF FAIL / SPOT	$D < 0.1 \text{ mm}$	IGNORE	$0.1 < D \leq 0.3\text{mm}$	$N \leq 3$
	AVERAGE DIAMETER (mm):D	NUMBER OF PIECES PERMITTED																				
BUBBLE ON THE POLARIZER	$D \leq 0.25$	IGNORE																				
	$0.25 < D \leq 0.5$	$N \leq 5$																				
	$0.5 < D$	NOTE																				
SURFACE STATUS	$D < 0.1 \text{ mm}$	IGNORE																				
	$0.1 < D \leq 0.3\text{mm}$	$N \leq 3$																				
CF FAIL / SPOT	$D < 0.1 \text{ mm}$	IGNORE																				
	$0.1 < D \leq 0.3\text{mm}$	$N \leq 3$																				
7	LINE DEFECT ON DISPLAY	OBVIOUS VERTICAL OR HORIZONTAL LINE DEFECT IS NOT ALLOW																				
8	MURA ON DISPLAY	IT'S OK IF MURA IS SLIGHT VISIBLE THROUNG 6% ND FILTER																				
9	UNEVEN COLOR SPREAD, COLORATION	(1)TO BE DETERMINED BASED UPON THE STANDARD SAMPLE.																				

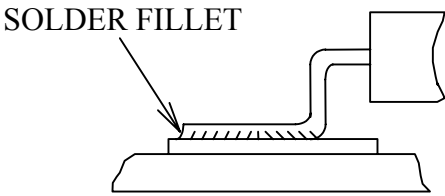
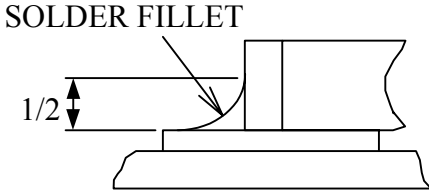
NO.	ITEM	CRITERIA
10	BEZEL APPEARANCE	(1)BEZEL MAY NOT HAVE RUST, E DEFORMED OR HAVE FINGER PRINTS STAINS OF OTHER CONTAMINATION. (2)BEZEL MUST COMPLY WITH JOB SPECIFICATIONS.
11	PCB	(1)THERE MAY NOT BE MORE THAN 2mm OF SEALANT OUTSIDE THE SEAL AREA ON THE PCB, AND THERE SHOULD BE NO MORE THAN THREE PLACES. (2)NO OXIDATION OR CONTAMINATION PCB TERMINALS (3)PARTS ON PCB MUST BE THE SAME AS ON THE PRODUCTION CHARACTERISTIC CHART. THERE SHOULD BE NO WRONG PARTS, MISSING PARTS OR EXCESS PARTS. (4)THE JUMPER ON THE PCB SHOULD CONFORM TO THE PRODUCT CHARACTERISTIC CHART. (5)IF SOLDER GETS ON BEZEL TAB PADS, LED PAD, ZEBRA PAD OR SCREW HOLD PAD, MAKE SURE IT IS SMOOTHED DOWN.
12	SOLDERING	(1)NO SOLDERING FOUND ON THE SPECIFIED PLACE (2)INSUFFICIENT SOLDER (a)LSI, IC A POOR WETTING OF SOLDER IS BETWEEN LOWER BEND OR "HEEL" OF LEAD AND PAD  (b)CHIP COMPONENT · SOLDER IS LESS THAN 50% OF SIDES AND FRONT FACE WETTING 

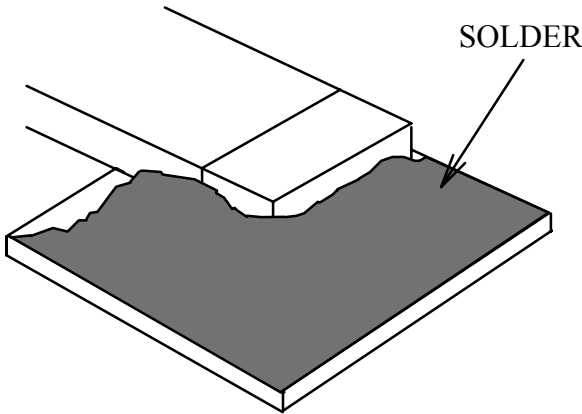
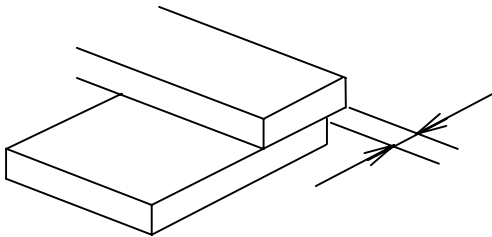
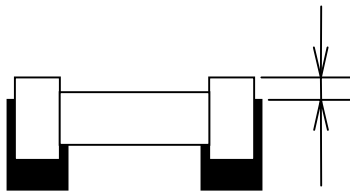
NO.	ITEM	CRITERIA
12.	SOLDERING	<ul style="list-style-type: none"> <li>• SOLDER WETS 3 SIDES OF TERMINAL, BUT LESS THAN 25% OF SIDES AND FRONT SURFACE AREA ARE COVERED</li> </ul>  <p>(3)PARTS ALIGMENT</p> <p>(a)LSI, IC LEAD WIDTH IS MORE THAN 50% BEYOND PAD OUTLINE</p>  <p>(b)CHIP COMPONENT COMPONENT IS OFF CENTER, AND MORE THAN 50% OF THE LEADS IS OFF THE PAD OUTLINE</p> 

NO.	ITEM	CRITERIA
12.	SOLDERING	<p>(4)NO UNMELTED SOLDER PASTE MAY BE PRESENT ON THE PCB.</p> <p>(5)NO COLD SOLDER JOINTS, MISSING SOLDER CONNECTIONS, OXIDATION OR ICICLE.</p> <p>(6)NO RESIDUE OR SOLDER BALLS ON PCB.</p> <p>(7)NO SHORT CIRCUITS IN COMPONENTS ON PCB.</p>
13.	BACKLIGHT	<p>(1)NO LIGHT</p> <p>(2)FLICKERING AND OTHER ABNORMAL ILLUMINATION</p> <p>(3)SPOTS OR SCRATCHES THAT APPEAR WHEN LIT MUST BE JUDGED USING LCD SPOT, LINES AND CONTAMINATION STANDARDS.</p> <p>(4)BACKLIGHT DOESN'T LIGHT OR COLOR IS WRONG.</p>
14.	GENERAL APPEARANCE	<p>(1)NO OXIDATION, CONTAMINATION, URVES OR,BENDS ON INTERFACE PIN (OLB) OF TCP.</p> <p>(2)NO CRACKS ON INTERFACE PIN (OLB) OF TCP.</p> <p>(3)NO CONTAMINATION, SOLDER RESIDUE OR SOLDER BALLS ON PRODUCT.</p> <p>(4)THE IC ON THE TCP MAY NOT BE DAMAGED, CIRCUITS.</p> <p>(5)THE UPPERMOST EDGE OF THE PROTECTIVE STRIP ON THE INTERFACE PIN MUST BE PRESENT OR LOOK AS IF IT CAUSE THE INTERFACE PIN TO SEVER.</p> <p>(6)THE RESIDUAL ROSIN OR TIN OIL OF SOLDERING (COMPONENT OR CHIP COMPONENT) IS NOT BURNED INTO BROWN OR BLACK COLOR.</p> <p>(7)SEALANT ON TOP OF THE ITO CIRCUIT HAS NOT HARDENED.</p> <p>(8)PIN TYPE MUST MATCH TYPE IN SPECIFICATION SHEET.</p> <p>(9)LCD PIN LOOSE OR MISSING PINS.</p> <p>(10)PRODUCT PACKAGING MUST THE SAME AS SPECIFIED ON PACKAGING SPECIFICATION SHEET.</p> <p>(11)PRODUCT DIMENSION AND STRUCTURE MUST CONFORM TO PRODUCT SPECIFICATION SHEET.</p> <p>(12)THE APPEARANCE OF HEAT SEAL SHOULD NOT ADMIT ANY DIRT AND BREAK.</p>

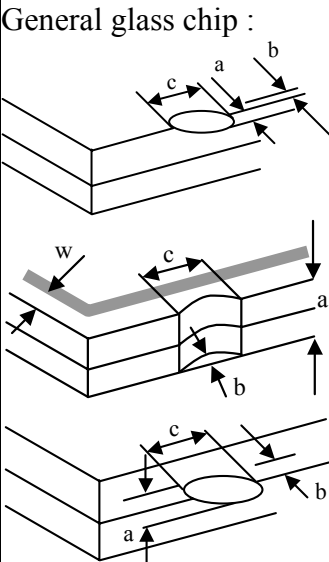
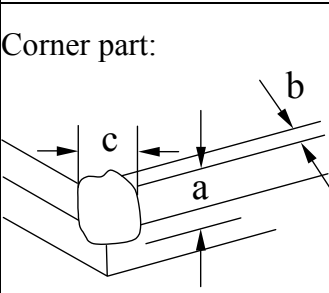
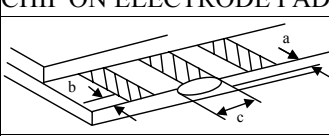
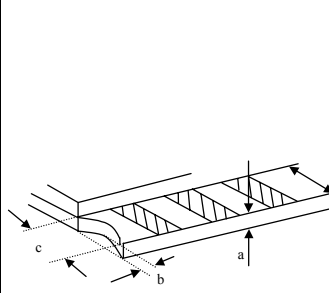
NO.	ITEM	CRITERIA									
15.	CRACKED GLASS	<p>THE LCD WITH EXTENSIVE CRACK IS NOT ACCEPTABLE</p> <p>General glass chip :</p>  <table border="1"> <thead> <tr> <th>a</th> <th>b</th> <th>c</th> </tr> </thead> <tbody> <tr> <td><math>\leq t/2</math></td> <td>&lt; VIEWING AREA</td> <td><math>\leq 1/8X</math></td> </tr> <tr> <td><math>t/2 &gt; , \leq 2t</math></td> <td><math>\leq W/2</math></td> <td><math>\leq 1/8X</math></td> </tr> </tbody> </table> <p>*W=DISTANCE BETWEEN SEALANT AREA AND LCD PANEL EDGE X = LCD SIDE LENGTH t = GLASS THICKNESS</p>	a	b	c	$\leq t/2$	< VIEWING AREA	$\leq 1/8X$	$t/2 > , \leq 2t$	$\leq W/2$	$\leq 1/8X$
		a	b	c							
		$\leq t/2$	< VIEWING AREA	$\leq 1/8X$							
		$t/2 > , \leq 2t$	$\leq W/2$	$\leq 1/8X$							
		<p>Corner part:</p>  <table border="1"> <thead> <tr> <th>a</th> <th>b</th> <th>c</th> </tr> </thead> <tbody> <tr> <td><math>\leq t/2</math></td> <td>&lt; VIEWING AREA</td> <td><math>\leq 1/8X</math></td> </tr> <tr> <td><math>&gt; t/2 , \leq 2t</math></td> <td><math>\leq W/2</math></td> <td><math>\leq 1/8X</math></td> </tr> </tbody> </table> <p>*W= DISTANCE BETWEEN SEALANT AREA AND LCD PANEL EDGE X=LCD SIDE LENGTH Y=GLASS THICKNESS</p>	a	b	c	$\leq t/2$	< VIEWING AREA	$\leq 1/8X$	$> t/2 , \leq 2t$	$\leq W/2$	$\leq 1/8X$
a	b	c									
$\leq t/2$	< VIEWING AREA	$\leq 1/8X$									
$> t/2 , \leq 2t$	$\leq W/2$	$\leq 1/8X$									
<p>CHIP ON ELECTRODE PAD</p>  <table border="1"> <thead> <tr> <th>a</th> <th>b</th> <th>c</th> </tr> </thead> <tbody> <tr> <td><math>\leq t</math></td> <td><math>\leq 0.5\text{mm}</math></td> <td><math>\leq 1/8X</math></td> </tr> </tbody> </table> <p>* X=LCD SIDE WIDTH t=GLASS THICKNESS</p>	a	b	c	$\leq t$	$\leq 0.5\text{mm}$	$\leq 1/8X$					
a	b	c									
$\leq t$	$\leq 0.5\text{mm}$	$\leq 1/8X$									
 <table border="1"> <thead> <tr> <th>a</th> <th>b</th> <th>c</th> </tr> </thead> <tbody> <tr> <td><math>\leq t</math></td> <td><math>\leq 1/8X</math></td> <td><math>\leq L</math></td> </tr> </tbody> </table> <p>*X=LCD SIDE WIDTH t = GLASS THICKNESS L=ELECTRODE PAD LENGTH</p> <p>①IF GLASS CHIPPING THE ITO TERMINAL, OVER 2/3 OF THE ITO MUST REMAIN AND BE, INSPECTED ACCORDING TO ELECTRODE TERMINAL SPECIFICATIONS</p> <p>②IF THE PRODUCT WILL BE HEAT SEALED BY THE CUSTOMER, THE ALIGNMENT MARK MUST NOT BE DAMAGED</p>	a	b	c	$\leq t$	$\leq 1/8X$	$\leq L$					
a	b	c									
$\leq t$	$\leq 1/8X$	$\leq L$									

13.4 RELIABILITY TEST

13.4.1 STANDARD SPECIFICATIONS FOR RELIABILITY OF LCD MODULE

NO	ITEM	DESCRIPTION
1	High temperature operation	The sample should be allowed to stand at +60°C for 240 hrs
2	Low temperature operation	The sample should be allowed to stand at -10°C for 240 hrs
3	High temperature storage	The sample should be allowed to stand at +70°C for 240 hrs
4	Low temperature storage	The sample should be allowed to stand at -20°C for 240 hrs
5	High temp / humidity test storage	The sample should be allowed to stand at 60°C, 90% RH 240 hrs
6	Thermal shock (not operated)	The sample should be allowed to stand the following 10 cycles of operation: -40°C for 30 minutes ~ +80°C for 30 minutes
7	ESD (Electrostatic Discharge) (not operated)	AIR DISCHARGE ± 12KV CONTACT DISCHARGE ± 8KV

NOTE (1) : THE TEST SAMPLES HAVE RECOVERY TIME FOR 2 HOURS AT ROOM TEMPERATURE BEFORE THE FUNCTION CHECK. IN THE STANDARD CONDITIONS, THERE IS NO DISPLAY FUNCTION NG ISSUE OCCURRED.

13.5 TESTING CONDITIONS AND INSPECTION CRITERIA

For the final test the testing sample must be stored at room temperature for 24 hours, after the tests listed in table 13.5 , standard specifications for reliability have been executed in order to ensure stability .

NO	ITEM	TEST MODEL	INSPECTION CRITERIA
1	Current consumption	Refer To Specification	The current consumption should conform to the product specification.
2	Contrast	Refer TO Specification	After the tests have been executed, the contrast must be larger than half of its initial value prior to the tests.
3	Appearance	Visual inspection	Defect free

### 13.6 OPERATION

- 13.6.1 Do not connect or disconnect modules to or from the main system while power is being supplied .
- 13.6.2 Use the module within specified temperature ; lower temperature causes the retardation of blinking speed of the display ; higher temperature makes overall display discolor . When the temperature returns to normality , the display will operate normally .
- 13.6.3 Adjust the LC driving voltage to obtain the optimum contrast .
- 13.6.4 Power On Sequence input signals should not be supplied to LCD module before power supply voltage is applied and reaches the specified value . If above sequence is not followed , CMOS LSIs of LCD modules may be damaged due to latch - up problem .
- 13.6.5 Not allowed to inflict any external stress and to cause any mechanical interference on the bending area of FPC during the tail bending backwards!  
Do not stress FPC and IC on the module!

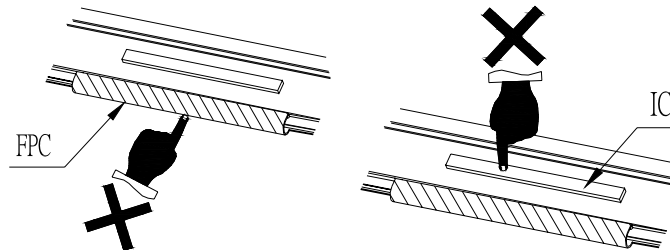

### 13.7 NOTICE

- 13.7.1 Use a grounded soldering iron when soldering connector I/O terminals . For soldering or repairing , take precaution against the temperature of the soldering iron and the soldering time to prevent peeling off the through-hole-pad .
- 13.7.2 Do not disassemble . EDT shall not be held responsible if the module is disassembled and upon the reassembly the module failed .
- 13.7.3 Do not charge static electricity , as the circuit of this module contains CMOS LSIs. A workman's body should always be static-protected by use of an ESD STRAP . Working clothes for such personnel should be of static-protected material .
- 13.7.4 Always ground the electrically-powered driver before using it to install the LCD module. While cleaning the work station by vacuum cleaner, do not bring the sucking mouth near the module ; static electricity of the electrically-powered driver or the vacuum cleaner may destroy the module .
- 13.7.5 Don't give external shock.
- 13.7.6 Don't apply excessive force on the surface.
- 13.7.7 Liquid in LCD is hazardous substance. Must not lick and swallow. When the liquid is attach to your, skin, cloth etc. Wash it out thoroughly and immediately.
- 13.7.8 Don't operate it above the absolute maximum rating.
- 13.7.9 Storage in a clean environment, free from dust, active gas, and solvent.
- 13.7.10 Store without any physical load.
- 13.7.11 Rewiring: no more than 3 times.