

EXAMINED BY :	EMERGING DISPLAY TECHNOLOGIES CORPORATION	FILE NO. CAS-0009584
<b>Sam Chou</b>		ISSUE : SEP.27, 2023
APPROVED BY:		TOTAL PAGE : 21
<i>Elvis Wu</i>		VERSION : 1

CUSTOMER ACCEPTANCE SPECIFICATIONS

MODEL NO. :

ET070013DCDMA

(RoHS)

FOR MESSRS :

\_\_\_\_\_

CUSTOMER'S APPROVAL

DATE :

\_\_\_\_\_

BY :

\_\_\_\_\_

EMERGING DISPLAY  
TECHNOLOGIES CORPORATION

MODEL NO.	VERSION	PAGE
ET070013DCDMA	1	0-1

RECORDS OF REVISION	DOC . FIRST ISSUE	SEP.27, 2023
---------------------	-------------------	--------------

DATE	REVISED PAGE NO.	SUMMARY
<p>CONFIDENTIAL</p> <p>Authorized for</p> <p>Emerging Display Technologies Corporation Only.</p> <p>Do not distribute without authorization.</p>		

TABLE OF CONTENTS

NO.	ITEM	PAGE
1.	GENERAL SPECIFICATIONS -----	1
2.	MECHANICAL SPECIFICATIONS -----	1
3.	ABSOLUTE MAXIMUM RATINGS -----	2
4.	ELECTRICAL CHARACTERISTICS -----	3
5.	TIMING CHARACTERISTICS -----	4 ~ 6
6.	OPTICAL CHARACTERISTICS -----	7, 8
7.	OUTLINE DIMENSIONS -----	9
8.	BLOCK DIAGRAM -----	10
9.	DETAIL DRAWING OF DOT MATRIX -----	11
10.	INTERFACE SIGNALS -----	12, 13
11.	POWER SUPPLY -----	14
12.	INSPECTION CRITERIA -----	15 ~ 18
13.	RELIABILITY TEST -----	19
14.	CAUTION -----	20, 21

CONFIDENTIAL  
Authorized for Emerging Display Technologies Corporation Only.  
Do not distribute without authorization.

## 1. GENERAL SPECIFICATIONS

### 1.1 DATA SHEETS FOR CONTROLLER/DRIVER

PLEASE REFER TO :

HIMAX HX8282-A11  
HIMAX HX8696-A01

### 1.2 MATERIAL SAFETY DESCRIPTION

ASSEMBLIES SHALL COMPLY WITH EUROPEAN ROHS REQUIREMENTS, INCLUDING PROHIBITED MATERIALS/COMPONENTS CONTAINING LEAD, MERCURY, CADMIUM, HEXAVALENT CHROMIUM, POLYBROMINATED BIPHENYLS (PBB) AND POLYBROMINATED DIPHENYL ETHERS (PBDE), BIS(2-ETHYLHEXYL) PHTHALATE (DEHP), BUTYL BENZYL PHTHALATE (BBP), DIBUTYL PHTHALATE (DBP), DIISOBUTYL PHTHALATE (DIBP).

## 2. MECHANICAL SPECIFICATIONS

( 1 ) DISPLAY SIZE	-----	7 inch
( 2 ) NUMBER OF DOTS	-----	1024(RGB)W * 600H DOTS
( 3 ) MODULE SIZE	-----	165.75W * 105.3H * 2.8D mm (NOT INCLUDED FPC)
( 4 ) VIEWING AREA	-----	156.41W * 88.12H mm
( 5 ) ACTIVE AREA	-----	154.21W * 85.92H mm
( 6 ) DOT SIZE	-----	0.0502W * 0.143H mm
( 7 ) PIXEL SIZE	-----	0.151W * 0.143H mm
( 8 ) LCD TYPE	-----	TFT , IPS , TRANSMISSIVE, NORMAL BLACK, ANTI-GLARE
( 9 ) COLOR	-----	262K/16.7M
( 10 ) VIEWING DIRECTION	-----	SUPER WIDE VIEW
( 11 ) BACK LIGHT	-----	LED , COLOR : WHITE
( 12 ) INTERFACE MODE	-----	LVDS(6 BIT/8 BIT)
( 13 ) WEIGHT	-----	102g

### 3. ABSOLUTE MAXIMUM RATINGS

#### 3.1 ELECTRICAL ABSOLUTE MAXIMUM RATINGS

ITEM	SYMBOL	MIN.	MAX.	UNIT	REMARK
POWER SUPPLY VOLTAGE	VDD-VSS	-0.5	3.96	V	
STATIC ELECTRICITY	—	—	—	V	NOTE (1)
POWER DISSIPATION FOR LED BACKLIGHT	PLED	—	2754	W	
FORWARD CURRENT FOR LED BACKLIGHT	ILED	—	270	mA	

NOTE (1) : LCM SHOULD BE GROUND DURING LCM HANDLING.

#### 3.2 ENVIRONMENTAL ABSOLUTE MAXIMUM RATINGS

ITEM	OPERATING		STORAGE		REMARK
	MIN.	MAX.	MIN.	MAX.	
AMBIENT TEMPERATURE	-20 °C	70 °C	-30 °C	80 °C	NOTE (1), (2), (3)
HUMIDITY	NOTE (3)		NOTE (3)		WITHOUT CONDENSATION
VIBRATION	—	2.45 m/s <sup>2</sup> (0.25 G)	—	11.76 m/s <sup>2</sup> (1.2 G)	10~100 Hz XYZ DIRECTIONS 1 HR EACH
SHOCK	—	29.4 m/s <sup>2</sup> (3 G)	—	490.0 m/s <sup>2</sup> (50 G)	10ms XYZ DIRECTIONS 1 TIME EACH

NOTE (1) : THE ABSOLUTE MAXIMUM RATINGS OF THIS PRODUCT SHOULD NOT BE EXCEEDED AT ANY TIME. IF THESE RATINGS ARE EXCEEDED, THE PRODUCT'S PERFORMANCE IS NOT GUARANTEED AND THE PRODUCT MAY EXPERIENCE PERMANENT DAMAGE.

NOTE (2) : BACKGROUND COLOR CHANGES SLIGHTLY DEPENDING ON AMBIENT TEMPERATURE THIS PHENOMENON IS REVERSIBLE.

NOTE (3) : Ta ≤ 60°C : 90%RH MAX. (96HRS MAX.)

Ta > 60°C : ABSOLUTE HUMIDITY MUST BE LOWER THAN THE HUMIDITY OF 90%RH AT 60°C. (96HRS MAX.)

4. ELECTRICAL CHARACTERISTICS

Ta = 25 °C

ITEM	SYMBOL	CONDITION	MIN.	TYP.	MAX.	UNIT	REMARK
POWER SUPPLY VOLTAGE FOR ANALOG	VDD-VSS	—	3.15	3.3	3.45	V	
LOGIC HIGH INPUT VOLTAGE	VIH	—	0.7*VDD	—	VDD	V	
LOGIC LOW INPUT VOLTAGE	VIL	—	0	—	0.3*VDD	V	
LOGIC HIGH OUTPUT VOLTAGE	VOH	I <sub>OH</sub> =-400μA	VDD-0.4	—	—	V	
LOGIC LOW OUTPUT VOLTAGE	VOL	I <sub>OL</sub> =400μA	—	—	VSS+0.4	V	
POWER SUPPLY CURRENT	IDD	VDD-VSS = 3.3V	—	165	215	mA	NOTE ( 1 )
POWER SUPPLY VOLTAGE FOR LED BACKLIGHT	VLED-VLSS	I <sub>LED</sub> =180mA	8.1	—	10.2	V	NOTE ( 2 ) NOTE ( 3 )
LED LIFE TIME	—	I <sub>F</sub> =20mA PER. LED	30K	—	—	hrs	NOTE ( 4 ) NOTE ( 5 )

NOTE ( 1 ) : THE DISPLAY PATTERN IS ALL “WHITE”.

NOTE ( 2 ) : INTERNAL CIRCUIT DIAGRAM OF BACKLIGHT

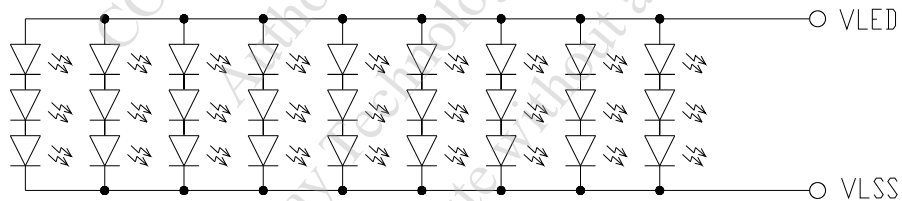

NOTE ( 3 ) : MAXIMUM DRIVING FORWARD DC CURRENT VS AMBIENT TEMPERATURE.

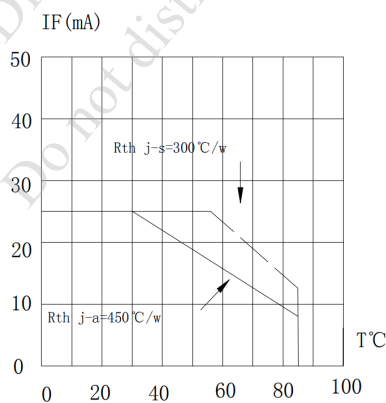

NOTE ( 4 ) : CONDITIONS; TA=25 °C, CONTINUOUS LIGHTING.

NOTE ( 5 ) : DEFINITIONS OF FAILURE

LCD LUMINANCE BECOMES HALF OF THE INITIAL VALUE.

5. TIMING CHARACTERISTICS

5.1 AC ELECTRICAL CHARACTERISTICS (LVDS)

ITEM	SYMBOL	CONDITION	MIN.	TYP.	MAX.	UNIT
CLOCK FREQUENCY	R <sub>XFCLK</sub>	—	20	—	71	MHz
INPUT DATA SKEW MARGIN	T <sub>RSKM</sub>	V <sub>ID</sub>  =400mV R <sub>XVCM</sub> =1.2V R <sub>XFCLK</sub> =71MHz	500	—	—	pS
CLOCK HIGH TIME	T <sub>LVCH</sub>	—	—	4/(7xR <sub>XFCLK</sub> )	—	ns
CLOCK LOW TIME	T <sub>LVCL</sub>	—	—	3/(7xR <sub>XFCLK</sub> )	—	ns
PLL WAKE-UP TIME	T <sub>enPLL</sub>	—	—	—	150	μs

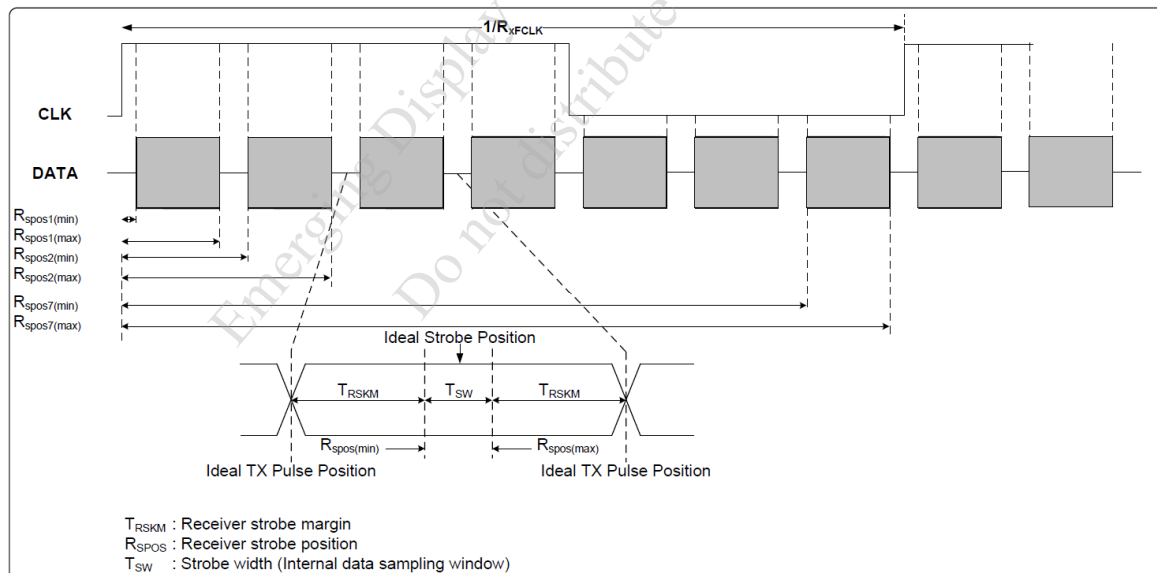
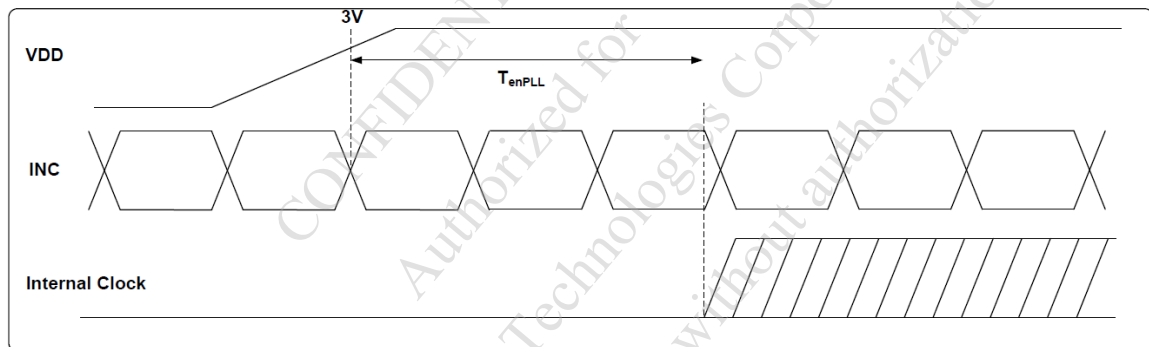
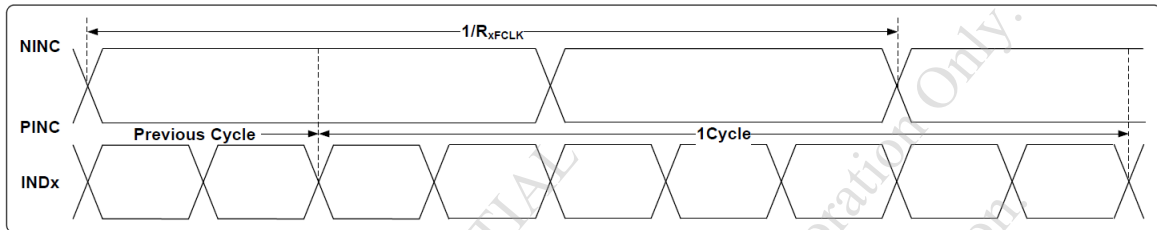

ITEM	SYMBOL	CONDITION	MIN.	TYP.	MAX.	UNIT
MODULATION FREQUENCY	SSC <sub>MF</sub>	—	23	—	93	KHz
MODULATION RATE	SSC <sub>MR</sub>	LVDS CLOCK=71MHz CENTER SPREAD	—	—	±3	%

5.2 DC ELECTRICAL CHARACTERISTICS

ITEM	SYMBOL	CONDITION	MIN.	TYP.	MAX.	UNIT
DIFFERENTIAL INPUT HIGH THRESHOLD VOLTAGE	$R_{xvth}$	$R_{xvcm}=1.2V$	—	—	+0.1	V
DIFFERENTIAL INPUT LOW THRESHOLD VOLTAGE	$R_{xvtl}$		-0.1	—	—	V
INPUT VOLTAGE RANGE (SINGLED-END)	$R_{xvin}$	—	0	—	$VDD-1.2 +  V_{ID} /2$	V
DIFFERENTIAL INPUT COMMON MODE VOLTAGE	$R_{xvcm}$	—	$ V_{ID} /2$	—	$VDD-1.2$	V
DIFFERENTIAL INPUT VOLTAGE	$ V_{ID} $	—	0.2	—	0.6	V
DIFFERENTIAL INPUT LEAKAGE CURRENT	$R_{V_{xIiz}}$	—	-10	—	+10	$\mu A$
LVDS DIGITAL OPERATING CURRENT	$I_{ddlvs}$	$F_{clk}=65MHz, VDD=3.3V$	—	15	30	mA
LVDS DIGITAL STAND-BY CURRENT	$I_{stlvs}$	CLOCK & ALL FUNCTIONS ARE STOPPED	—	10	50	$\mu A$

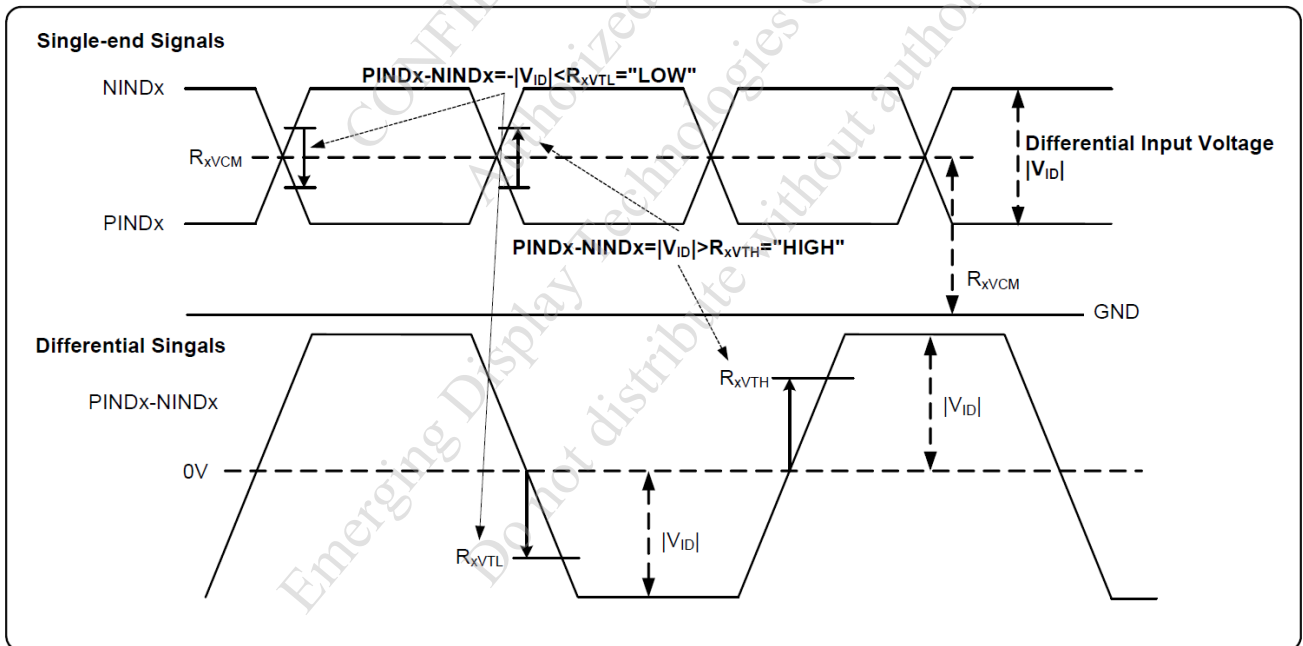

### 5.3 TIMING (DE MODE)

ITEM	SYMBOL	MIN.	TYP.	MAX.	UNIT
DCLK FREQUENCY	felk	40.8	51.2	67.2	MHz
HORIZONTAL DISPLAY AREA	thd	1024			DCLK
HSD PERIOD	th	1114	1344	1400	DCLK
HSD BLANKING	thb+thfp	90	320	376	DCLK
VERTICAL DISPLAY AREA	tvd	600			T <sub>H</sub>
VSD PERIOD	tv	610	635	800	T <sub>H</sub>
VSD BLANKING	tvbp+tvfp	10	35	200	T <sub>H</sub>

### 5.4 DATA INPUT FORMAT

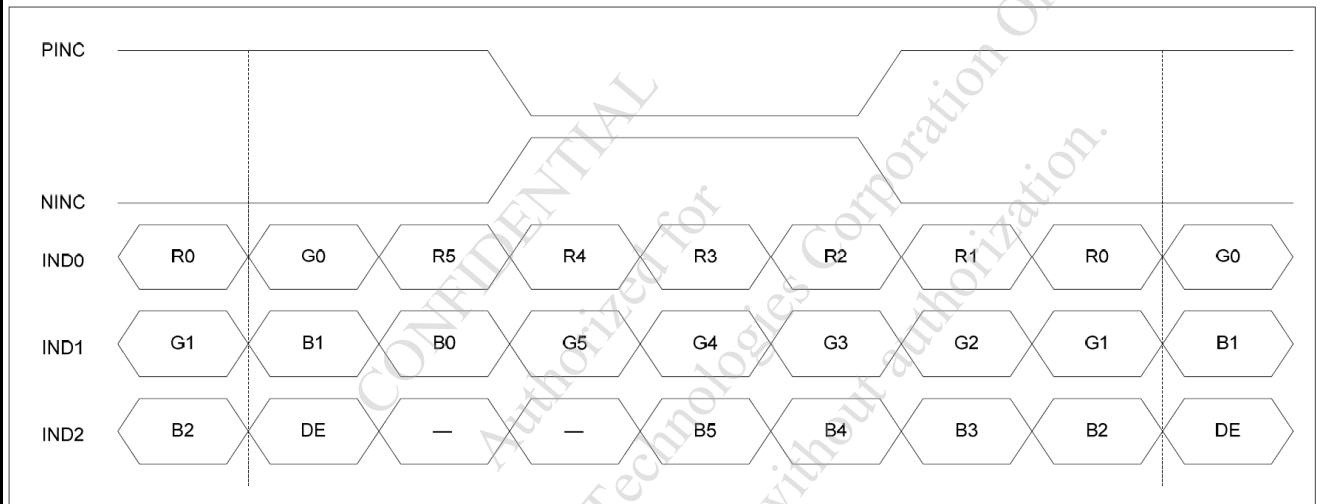

6-BIT LVDS INPUT

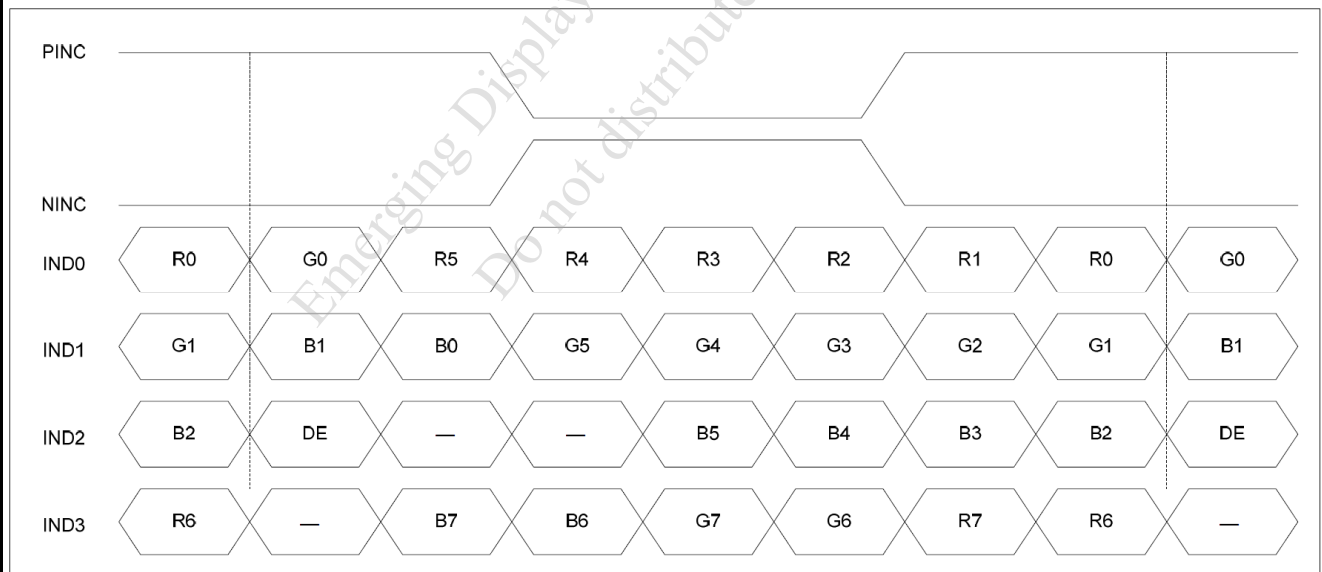

8-BIT LVDS INPUT

## 6. OPTICAL CHARACTERISTICS

### 6.1 OPTICAL CHARACTERISTICS

Ta=25±2°C

ITEM	SYMBOL	CONDITION	MIN.	TYP.	MAX.	UNIT	REMARK	
VIEWING ANGLE	$\theta_{y+}$	CR≥10	$\theta_x=0^\circ$	80	85	—	deg	NOTE (2) NOTE (3)
	$\theta_{y-}$			80	85	—		
	$\theta_{x+}$		$\theta_y=0^\circ$	80	85	—		
	$\theta_{x-}$			80	85	—		
CONTRAST RATIO (CENTER)	CR	$\theta_x=0^\circ, \theta_y=0^\circ$	600	800	—	—	NOTE (3)	
RESPONSE TIME	T <sub>R</sub> (rise)+ T <sub>F</sub> (fall)		—	30	40	msec.	NOTE (4)	
COLOR CHROMATICITY (CENTER)	WHITE	$\theta_x=0^\circ, \theta_y=0^\circ$ VDD-VSS=3.3V ILED=180mA	W <sub>x</sub>	0.25	0.30	0.35	—	NOTE (5)
			W <sub>y</sub>	0.26	0.31	0.36		
	RED		R <sub>x</sub>	0.54	0.59	0.64	—	
			R <sub>y</sub>	0.30	0.35	0.40		
	GREEN		G <sub>x</sub>	0.28	0.33	0.38	—	
			G <sub>y</sub>	0.52	0.57	0.62		
	BLUE		B <sub>x</sub>	0.11	0.16	0.21	—	
			B <sub>y</sub>	0.04	0.09	0.14		
THE BRIGHTNESS OF MODULE(CENTER)	B		400	500	—	cd/m <sup>2</sup>	NOTE (6)	
THE UNIFORMITY OF MODULE(9 POINTS)	—		70	—	—	%	NOTE (7)	

NOTE (1) : TEST CONDITION :

AFTER STABILIZING AND LEAVING THE PANEL ALONE AT A GIVEN TEMPERATURE FOR 30 MINUTES. MEASUREMENT SHOULD BE EXECUTED IN A STABLE, WINDLESS, AND DARK ROOM.

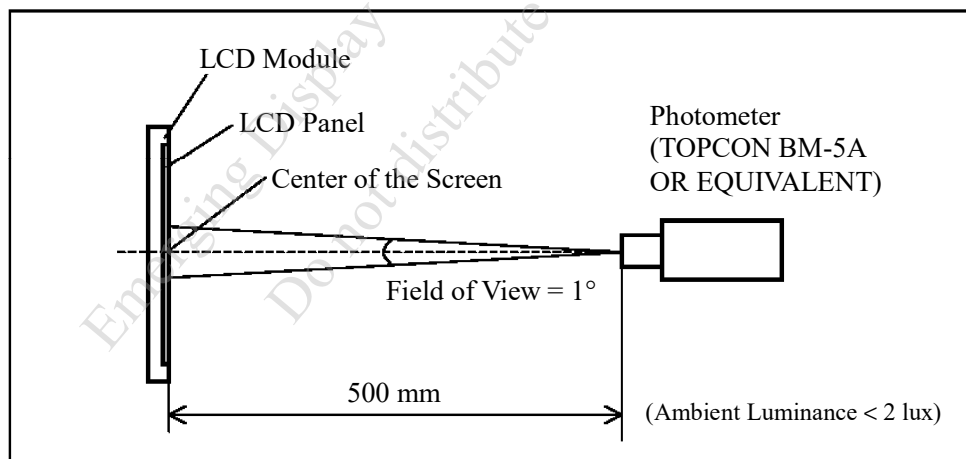

NOTE (2) : DEFINITION OF VIEWING ANGLE :

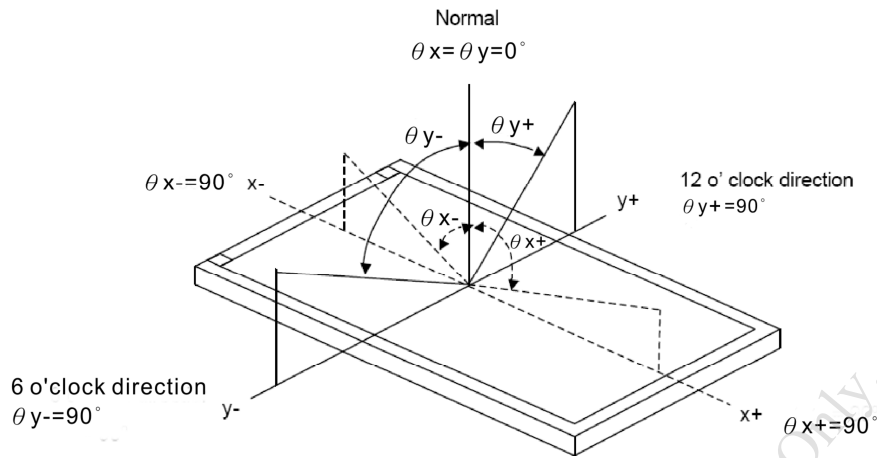

NOTE (3) : DEFINITION OF CONTRAST RATIO (CR) :  
MEASURED AT THE CENTER POINT OF MODULE

$$\text{CONTRAST RATIO(CR)} = \frac{\text{BRIGHTNESS MEASURED WHEN LCD IS AT "WHITE STATE"}}{\text{BRIGHTNESS MEASURED WHEN LCD IS AT "BLACK STATE"}}$$

NOTE (4) : DEFINITION OF RESPONSE TIME : T<sub>R</sub> AND T<sub>F</sub>

THE FIGURE BELOW IS THE OUTPUT SIGNAL OF THE PHOTO DETECTOR.

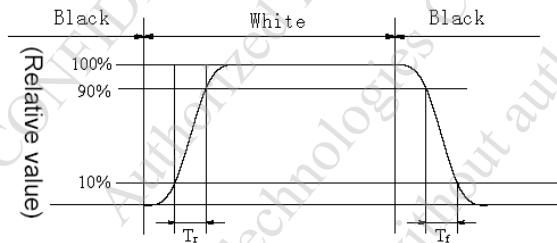

NOTE (5) : DEFINITION OF COLOR CHROMATICITY

(a) 100% RGB PIXEL DATA TRANSMISSION WHEN ALL THE INPUT TERMINALS OF MODULE ARE ELECTRICALLY POWERED ON.

(b) MEASURED AT THE CENTER POINT OF MODULE

NOTE (6) : MEASURED THE BRIGHTNESS OF WHITE STATE AT CENTER POINT.

NOTE (7) : (a) DEFINITION OF BRIGHTNESS UNIFORMITY

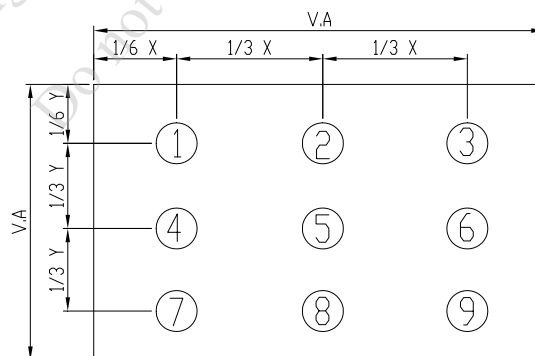

UNIT : mm

(b) THE BRIGHTNESS UNIFORMITY CALCULATING METHOD

$$\text{UNIFORMITY} : \frac{\text{MINIMUM BRIGHTNESS}}{\text{MAXIMUM BRIGHTNESS}} * 100\%$$

7. OUTLINE DIMENSIONS

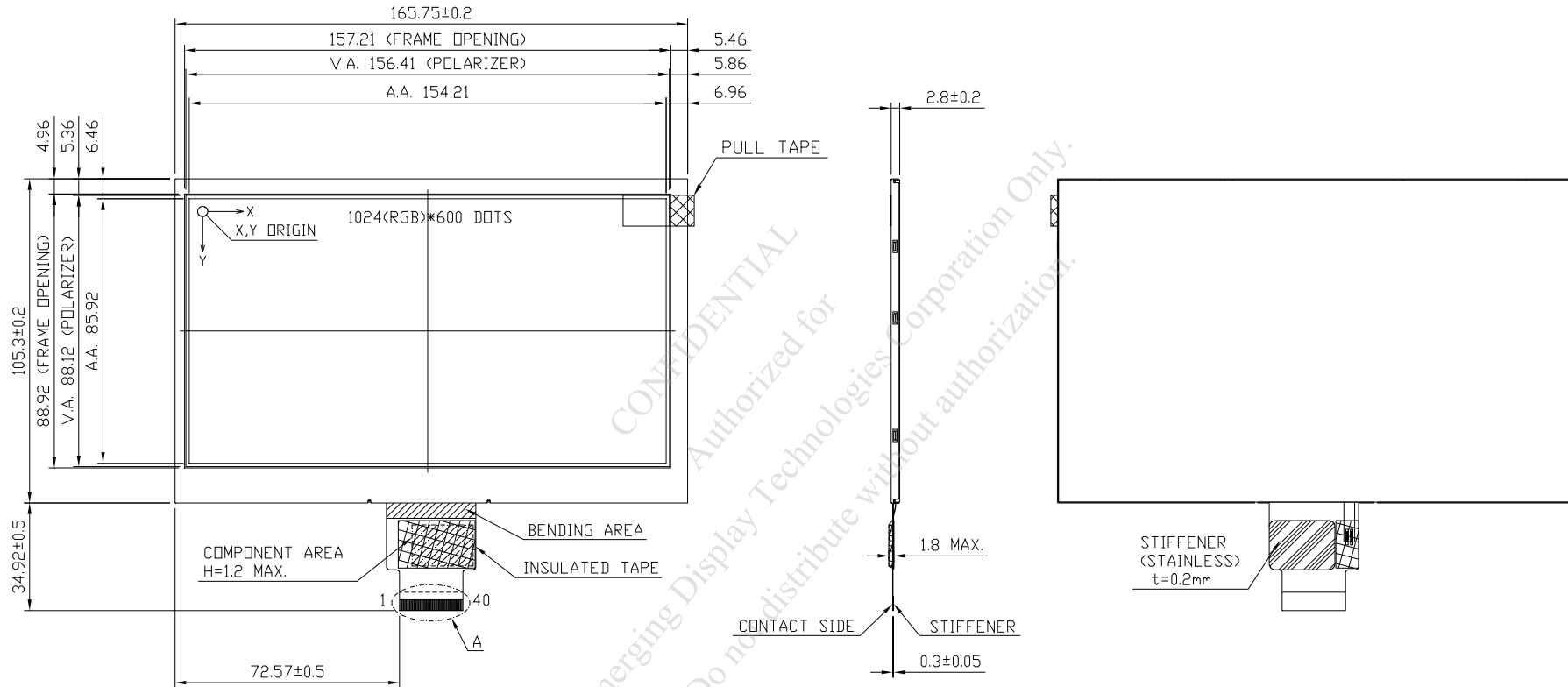

UNIT : mm  
SCALE : NTS

THIRD ANGLE PROJECTION

NOT SPECIFIED TOLERANCE IS  $\pm 0.3$

1. RECOMMEND MATCH CONNECTOR KYOCERA : 04 6240 040 SERIES.

2. FPC BENDING RADIUS SHOULD BE MORE THAN 1.0 mm.

8. BLOCK DIMENSION

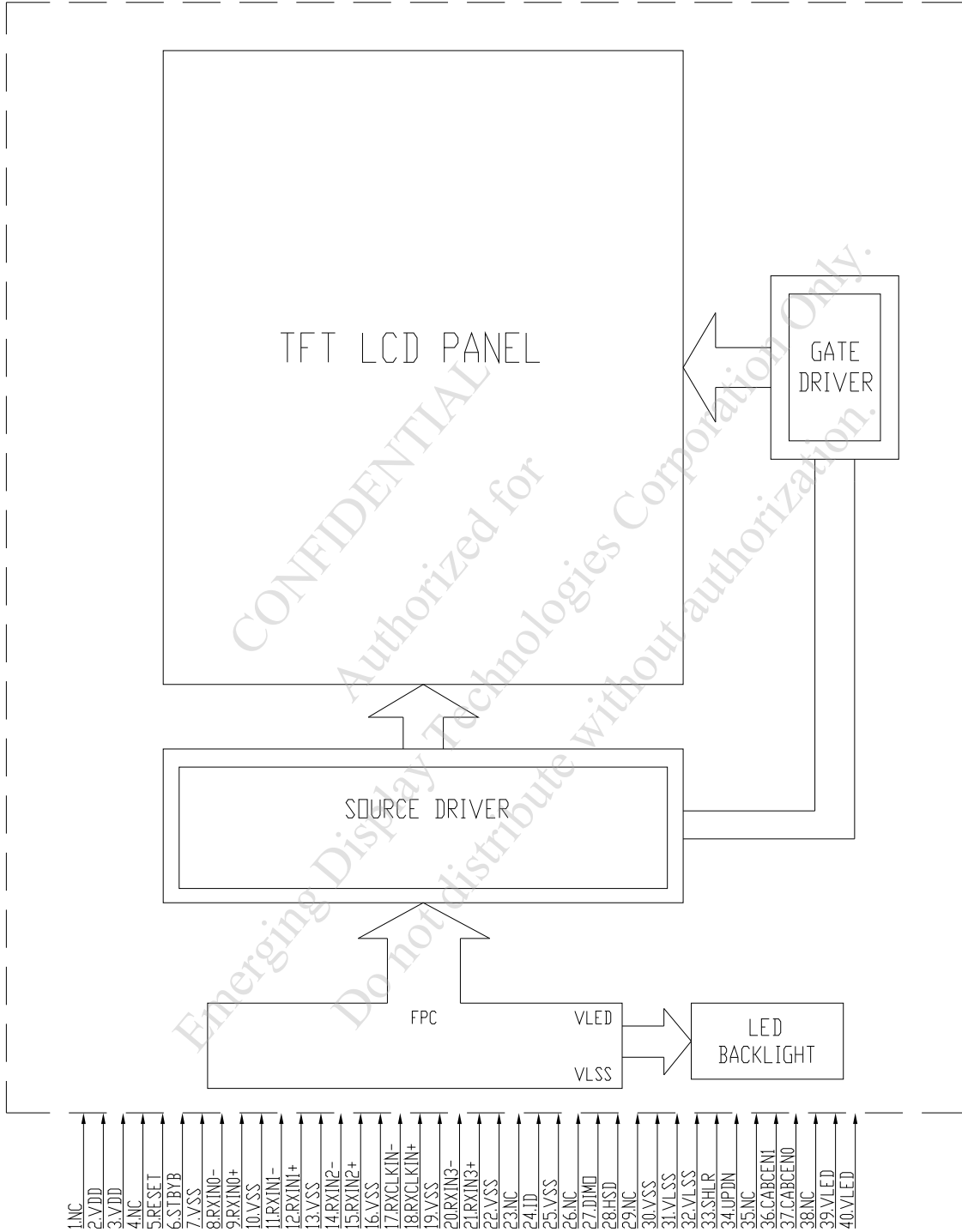

9. DETAIL DRAWING OF DOT MATRIX

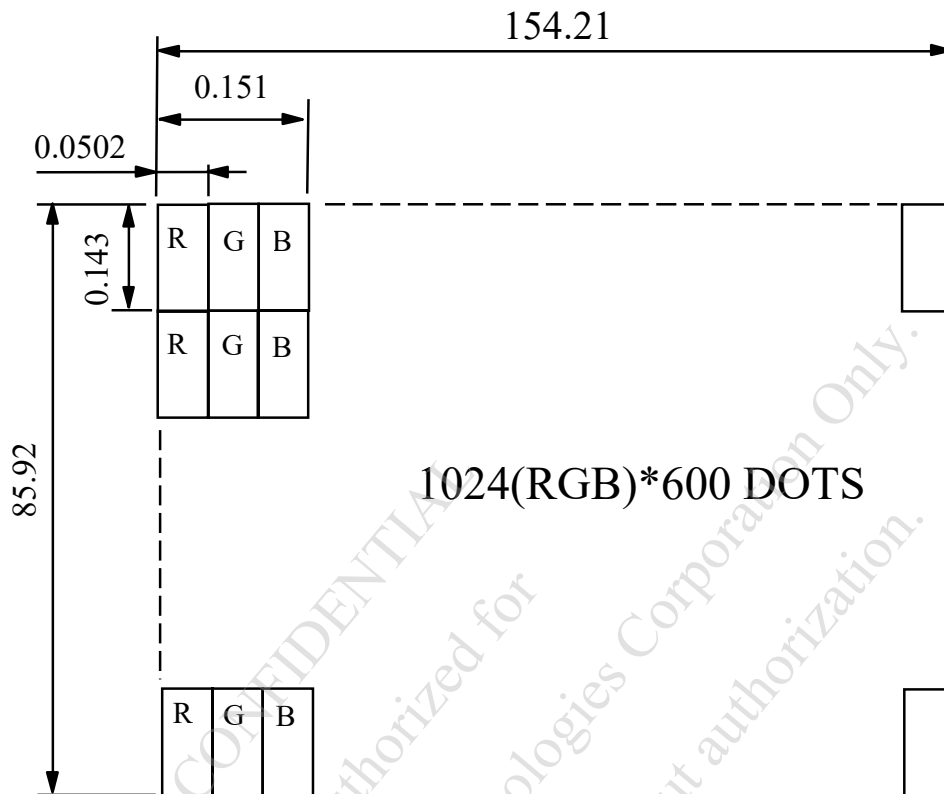

UNIT : mm  
SCALE : NTS  
NOT SPECIFIED TOLERANCE IS  $\pm 0.1$   
DOTS MATRIX TOLERANCE IS  $\pm 0.01$

CONFIDENTIAL  
Authorized for Emerging Display Technologies Corporation Only.  
Do not distribute without authorization.

10. INTERFACE SIGNALS

PIN NO.	SYMBOL	FUNCTION						
1	NC	NON CONNECTION						
2	VDD	POWER SUPPLY VOLTAGE						
3	VDD	POWER SUPPLY VOLTAGE						
4	NC	NON CONNECTION						
5	RESET	GLOBAL RESET PIN						
6	STBYB	STANDBY MODE CONTROL. NORMALLY PULL HIGH. WHEN STB=H: ALL THE FUNCTIONS ARE ON. (DEFAULT PULLS HIGH) WHEN STB=L: TCON AND SOURCE DRIVER ARE OFF AND ALL OUTPUT ARE VSS.						
7	VSS	GROUND						
8	RXIN0-	LVDS SIGNAL (-) — CHANNEL 0 (R0~R5,G0)						
9	RXIN0+	LVDS SIGNAL (+) — CHANNEL 0 (R0~R5,G0)						
10	VSS	GROUND						
11	RXIN1-	LVDS SIGNAL (-) — CHANNEL 1 (G1~G5,B0~B1)						
12	RXIN1+	LVDS SIGNAL (+) — CHANNEL 1 (G1~G5,B0~B1)						
13	VSS	GROUND						
14	RXIN2-	LVDS SIGNAL (-) — CHANNEL 2 (B2~B5,VS,HS,DE)						
15	RXIN2+	LVDS SIGNAL (+) — CHANNEL 2 (B2~B5,VS,HS,DE)						
16	VSS	GROUND						
17	RXCLKIN-	LVDS CLOCK SIGNAL (-)						
18	RXCLKIN+	LVDS CLOCK SIGNAL (+)						
19	VSS	GROUND						
20	RXIN3-	LVDS SIGNAL (-) — CHANNEL 3 (R6,R7,G6,G7,B6,B7)						
21	RXIN3+	LVDS SIGNAL (+) — CHANNEL 3 (R6,R7,G6,G7,B6,B7)						
22	VSS	GROUND						
23	NC	NON CONNECTION						
24	ID	OUTPUT A VOLTAGE FOR IDENTITY ; CONNECT TO 10KΩ RESISTANCE TO VSS.						
25	VSS	GROUND						
26	NC	NON CONNECTION						
27	DIMO	BACKLIGHT DIMMER SIGNAL FOR EXTERNAL CONTROLLER. DIMO=H: LOGICAL CONTROL SIGNAL TO TURN ON EXTERNAL BACKLIGHT CONTROLLER. DIMO=L: TURN OFF EXTERNAL BACKLIGHT CONTROLLER. PLEASE KEEP FLOATING IF NOT USE. (IF CABG OFF, DIMO=DIMI. ELSE DIMO IS CONTROLLED BY CABG.)						
28	HSD	IN TTL MODE, FOR HORIZONTAL SYNC INPUT. NEGATIVE POLARITY. IN LVDS MODE, USED AS 6-BIT/8-BIT INPUT SELECT. <table border="1" style="margin-left: auto; margin-right: auto;"> <thead> <tr> <th>HSD Bit</th> <th>HSD Bit</th> </tr> </thead> <tbody> <tr> <td>L</td> <td>8-bit</td> </tr> <tr> <td>H</td> <td>6-bit (Default)</td> </tr> </tbody> </table>	HSD Bit	HSD Bit	L	8-bit	H	6-bit (Default)
HSD Bit	HSD Bit							
L	8-bit							
H	6-bit (Default)							

PIN NO.	SYMBOL	FUNCTION
29	NC	NON CONNECTION
30	VSS	GROUND
31	VLSS	GROUND
32	VLSS	GROUND
33	SHLR	SOURCE DRIVER INTERNAL SHIFT REGISTER IS CONTROLLED BY THIS PIN AS SHOWN BELOW: NORMALLY PULL HIGH. SHLR =H: SO1→SO2→SO3→...→SO1536. (DEFAULT) SHLR =L: SO1536→SO1535→SO1534→...→SO1.
34	UPDN	GATE DRIVER UP/DOWN SCAN SETTING. NORMALLY PULL LOW. WHEN UPDN =H: REVERSE SCAN. STV1 OUTPUT VERTICAL START PULSE AND UPDN PIN OUTPUT "H" TO GATE DRIVER. WHEN UPDN =L, NORMAL SCAN. (DEFAULT) STV2 OUTPUT VERTICAL START PULSE AND UPDN PIN OUTPUT "L" TO GATE DRIVER.
35	NC	NON CONNECTION
36	CABCEN1	CABC H/W ENABLE PIN. NORMALLY PULL LOW. WHEN CABC_EN="00": CABC OFF. (DEFAULT MODE)
37	CABCEN0	WHEN CABC_EN="01": USER INTERFACE IMAGE. WHEN CABC_EN="10": STILL PICTURE. WHEN CABC_EN="11": MOVING IMAGE.
38	NC	NON CONNECTION
39	VLED	POWER SUPPLY VOLTAGE FOR LED BACKLIGHT
40	VLED	POWER SUPPLY VOLTAGE FOR LED BACKLIGHT

11. POWER SUPPLY

11.1 POWER SUPPLY FOR LCM

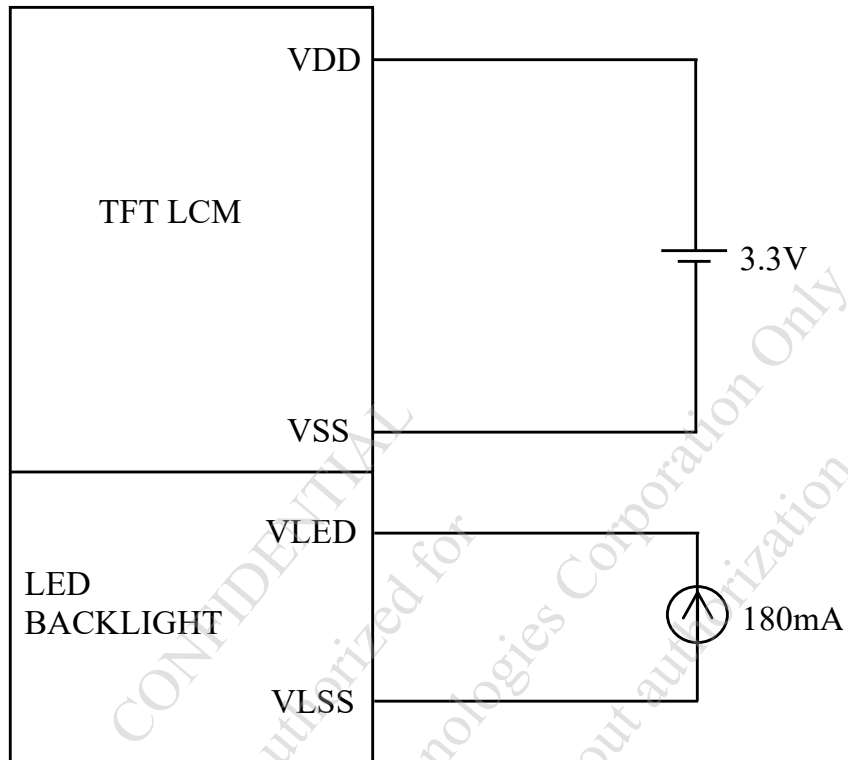

CONFIDENTIAL  
Authorized for Emerging Display Technologies Corporation Only.  
Do not distribute without authorization.

12. INSPECTION CRITERIA

12.1 APPLICATION

THIS INSPECTION STANDARD IS TO BE APPLIED TO THE LCD MODULE DELIVERED FROM EMERGING DISPLAY TECHNOLOGIES CORP.( E.D.T ) TO CUSTOMERS

12.2 INSPECTION CONDITIONS

12.2.1 (1)OBSERVATION DISTANCE : 45±5cm

(2)VIEWING ANGLE : ±45°

±45° (FOR SECTION WITHIN VIEWING AREA), REFER TO FIG.A  
90° (FOR SECTION OUTSIDE OF VIEWING AREA), REF TO FIG.B  
PERPENDICULAR TO MODULE SURFACE

VIEWING ANGLE SHOULD BE SMALLER THAN 45°

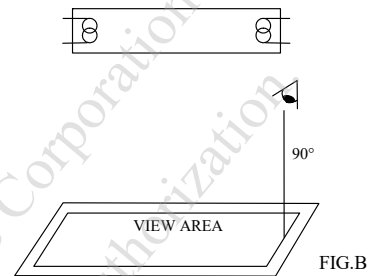
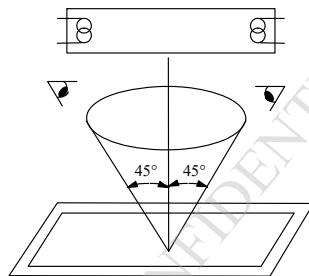

THE INSPECTION CRITERIA IS ACCORDING TO LINE OF SIGHT. INSPECTION SHALL BE MADE WITHIN THE HALF SECTION OF THE VIEWING CONE GENERATED BY LINE SEGMENT OF 45° WITH RESPECT TO THE VERTICAL AXIS FROM CENTER VERTEX OF LCD, THE FLUORESCENT LAMP AND THE CONE AXIS MUST BE PERPENDICULAR TO THE LCD SURFACE.

IF THE DEFECTS ARE OUTSIDE OF VIEWING AREA, IT SHALL BE INSPECTED BY 90° WITH RESPECT TO THE VERTICAL AXIS FROM EDGE OF VIEWING AREA.

12.2.2 ENVIRONMENT CONDITIONS :

AMBIENT TEMPERATURE		25±5°C
AMBIENT HUMIDITY		65 ± 20%RH
AMBIENT ILLUMINATION	COSMETIC INSPECTION	600~800 lux
	FUNCTIONAL INSPECTION	300~500 lux
INSPECTION TIME		10 secs

12.2.3 INSPECTION LOT

QUANTITY PER DELIVERY LOT FOR EACH MODEL

12.2.4 INSPECTION METHOD

A SAMPLING INSPECTION SHALL BE MADE ACCORDING TO THE FOLLOWING PROVISIONS TO JUDGE THE ACCEPTABILITY

(a)APPLICABLE STANDARD :

ANSI/ ASQ Z1.4 NORMAL INSPECTION LEVEL II

(b)AQL : MAJOR DEFECT : AQL 0.65

MINOR DEFECT : AQL 1.0

12.3 INSPECTION STANDARDS

12.3.1 VISUAL DEFECTS CLASSIFICATION

TYPE OF DEFECT	INSPECTION ITEM	DEFECT FEATURE	AQL
MAJOR DEFECT	1.DISPLAY ON	<ul style="list-style-type: none"> <li>• DEFECT TO MISS SPECIFIED DISPLAY FUNCTION, FOR ALL AND SPECIFIED DOTS</li> <li>EX: DISCONNECTION, SHORT CIRCUIT ETC</li> </ul>	0.65
	2.BACKLIGHT	<ul style="list-style-type: none"> <li>• NO LIGHT</li> <li>• FLICKERING AND OTHER ABNORMAL ILLUMINATION</li> </ul>	
	3.DIMENSIONS	<ul style="list-style-type: none"> <li>• SUBJECT TO INDIVIDUAL ACCEPTANCE SPECIFICATIONS</li> </ul>	
MINOR DEFECT	1.DISPLAY ZONE	<ul style="list-style-type: none"> <li>• BLACK/WHITE SPOT</li> <li>• BUBBLES ON POLARIZER</li> <li>• NEWTON RING</li> <li>• BLACK/WHITE LINE</li> <li>• SCRATCH</li> <li>• CONTAMINATION</li> <li>• LEVER COLOR SPREAD</li> </ul>	1.0
	2.BEZEL ZONE	<ul style="list-style-type: none"> <li>• STAINS</li> <li>• SCRATCHES</li> <li>• FOREIGN MATTER</li> </ul>	
	3.SOLDERING	<ul style="list-style-type: none"> <li>• INSUFFICIENT SOLDER</li> <li>• SOLDERED IN INCORRECT POSITION</li> <li>• CONVEX SOLDERING SPOT</li> <li>• SOLDER BALLS</li> <li>• SOLDER SCRAPS</li> </ul>	
	4.DISPLAY ON (ALL ON)	<ul style="list-style-type: none"> <li>• LIGHT LINE</li> </ul>	

12.3.2 MODULE DEFECTS CLASSIFICATION

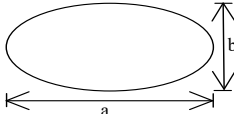
NO.	ITEM	CRITERIA																							
1	DISPLAY ON INSPECTION	1. INCORRECT PATTERN 2. MISSING SEGMENT 3. DIM SEGMENT 4. OPERATING VOLTAGE BEYOND SPEC																							
2	OVERALL DIMENSIONS	1. OVERALL DIMENSION BEYOND SPEC																							
3	DOT DEFECT	<p>1. INSPECTION PATTERN: FULL WHITE, FULL BLACK, RED, GREEN AND BLUE SCREENS.</p> <p>2.</p> <table border="1"> <thead> <tr> <th colspan="2">ITEM</th> <th>ACCEPTABLE COUNT</th> </tr> </thead> <tbody> <tr> <td rowspan="3">BRIGHT DOT</td> <td>RANDOM</td> <td>N = 3</td> </tr> <tr> <td>2 DOTS ADJACENT (PAIR)</td> <td>N = 0</td> </tr> <tr> <td>3 DOTS ADJACENT OR MORE</td> <td>N = 0</td> </tr> <tr> <td rowspan="3">DARK DOT</td> <td>RANDOM</td> <td>N ≤ 4</td> </tr> <tr> <td>2 DOTS ADJACENT (PAIR)</td> <td>N = 0</td> </tr> <tr> <td>3 DOTS ADJACENT OR MORE</td> <td>N = 0</td> </tr> <tr> <td colspan="2">TOTAL BRIGHT AND DARK DOT</td> <td>N ≤ 6</td> </tr> <tr> <td>DISTANCE</td> <td>MINIMUM DISTANCE BETWEEN DARK DOTS MINIMUM DISTANCE BETWEEN DARK AND BRIGHT DOT.</td> <td>5 mm</td> </tr> </tbody> </table> <p>NOTE :</p> <p>1. THE DEFINITION OF DOT : THE SIZE OF A DEFECTIVE DOT OVER 1/2 OF WHOLE DOT IS REGARDED AS ONE DEFECTIVE DOT. THE BRIGHT DOT DEFECT MOST BE VISIBLE THROUGH A 5% ND FILTER</p> <p>2. BRIGHT DOT : DOTS APPEAR BRIGHT AND UNCHANGED IN SIZE IN WHICH LCD PANEL IS DISPLAYING UNDER BLACK PATTERN.</p> <p>3. DARK DOT : DOTS APPEAR DARK AND UNCHANGED IN SIZE IN WHICH LCD PANEL IS DISPLAYING UNDER PURE RED, GREEN, BLUE PICTURE.</p>	ITEM		ACCEPTABLE COUNT	BRIGHT DOT	RANDOM	N = 3	2 DOTS ADJACENT (PAIR)	N = 0	3 DOTS ADJACENT OR MORE	N = 0	DARK DOT	RANDOM	N ≤ 4	2 DOTS ADJACENT (PAIR)	N = 0	3 DOTS ADJACENT OR MORE	N = 0	TOTAL BRIGHT AND DARK DOT		N ≤ 6	DISTANCE	MINIMUM DISTANCE BETWEEN DARK DOTS MINIMUM DISTANCE BETWEEN DARK AND BRIGHT DOT.	5 mm
ITEM		ACCEPTABLE COUNT																							
BRIGHT DOT	RANDOM	N = 3																							
	2 DOTS ADJACENT (PAIR)	N = 0																							
	3 DOTS ADJACENT OR MORE	N = 0																							
DARK DOT	RANDOM	N ≤ 4																							
	2 DOTS ADJACENT (PAIR)	N = 0																							
	3 DOTS ADJACENT OR MORE	N = 0																							
TOTAL BRIGHT AND DARK DOT		N ≤ 6																							
DISTANCE	MINIMUM DISTANCE BETWEEN DARK DOTS MINIMUM DISTANCE BETWEEN DARK AND BRIGHT DOT.	5 mm																							
4	FOREIGN BLACK/WHITE/ BRIGHT LINE/ OF VIEWING AREA	<table border="1"> <thead> <tr> <th>LENGTH : L</th> <th>WIDTH : W</th> <th>PERMISSIBLE NO.</th> </tr> </thead> <tbody> <tr> <td>—</td> <td><math>W \leq 0.07</math></td> <td>IGNORE</td> </tr> <tr> <td><math>L \leq 5.0</math></td> <td><math>0.07 &lt; W \leq 0.2</math></td> <td>4</td> </tr> <tr> <td><math>5.0 &lt; L</math></td> <td><math>W &gt; 0.2</math></td> <td>NONE</td> </tr> </tbody> </table> <p>DS&gt;10 mm, WIDTH : W mm, LENGTH : L mm</p>	LENGTH : L	WIDTH : W	PERMISSIBLE NO.	—	$W \leq 0.07$	IGNORE	$L \leq 5.0$	$0.07 < W \leq 0.2$	4	$5.0 < L$	$W > 0.2$	NONE											
LENGTH : L	WIDTH : W	PERMISSIBLE NO.																							
—	$W \leq 0.07$	IGNORE																							
$L \leq 5.0$	$0.07 < W \leq 0.2$	4																							
$5.0 < L$	$W > 0.2$	NONE																							
5	POLARIZER SCRATCHES	<table border="1"> <thead> <tr> <th>LENGTH : L</th> <th>WIDTH : W</th> <th>PERMISSIBLE NO.</th> </tr> </thead> <tbody> <tr> <td>—</td> <td><math>W \leq 0.07</math></td> <td>IGNORE</td> </tr> <tr> <td><math>L \leq 5.0</math></td> <td><math>0.07 &lt; W \leq 0.2</math></td> <td>4</td> </tr> <tr> <td><math>5.0 &lt; L</math></td> <td><math>W &gt; 0.2</math></td> <td>NONE</td> </tr> </tbody> </table> <p>DS&gt;10 mm, WIDTH : W mm, LENGTH : L mm</p>	LENGTH : L	WIDTH : W	PERMISSIBLE NO.	—	$W \leq 0.07$	IGNORE	$L \leq 5.0$	$0.07 < W \leq 0.2$	4	$5.0 < L$	$W > 0.2$	NONE											
LENGTH : L	WIDTH : W	PERMISSIBLE NO.																							
—	$W \leq 0.07$	IGNORE																							
$L \leq 5.0$	$0.07 < W \leq 0.2$	4																							
$5.0 < L$	$W > 0.2$	NONE																							
6	FOREIGN MATTER \ BLACK SPOTS \ WHITE SPOTS \ DENT (INCLUDING LIGHT LEAKAGE DUE TO POLARIZING PLATES PINHOLES, ETC.)	<table border="1"> <thead> <tr> <th>AVERAGE DIAMETER (mm): D</th> <th>NUMBER OF PIECES PERMITTED</th> </tr> </thead> <tbody> <tr> <td><math>D \leq 0.15</math></td> <td>IGNORE</td> </tr> <tr> <td><math>0.15 &lt; D \leq 0.5</math></td> <td>4</td> </tr> <tr> <td><math>D &gt; 0.5</math></td> <td>NONE</td> </tr> </tbody> </table> <p>NOTE : DIAMETER <math>D=(a+b)/2</math></p>  <p>DS&gt;10 mm</p>	AVERAGE DIAMETER (mm): D	NUMBER OF PIECES PERMITTED	$D \leq 0.15$	IGNORE	$0.15 < D \leq 0.5$	4	$D > 0.5$	NONE															
AVERAGE DIAMETER (mm): D	NUMBER OF PIECES PERMITTED																								
$D \leq 0.15$	IGNORE																								
$0.15 < D \leq 0.5$	4																								
$D > 0.5$	NONE																								

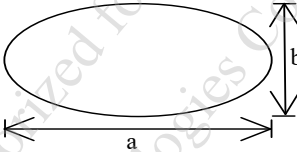
NO.	ITEM	CRITERIA		
			AVERAGE DIAMETER (mm) : D	NUMBER OF PIECES PERMITTED
7	BUBBLES OF POLARIZER /DIRT/CF FAIL /SURFACE STAINS	BUBBLE ON THE POLARIZER	$D \leq 0.15$	IGNORE
			$0.15 < D \leq 0.5$	$N \leq 4$
			$0.5 < D$	NONE
		SURFACE STAINS	$D \leq 0.15$	IGNORE
			$0.15 < D \leq 0.5$	$N \leq 4$
			$0.5 < D$	NONE
		CF FAIL / SPOT	$D \leq 0.15$	IGNORE
			$0.15 < D \leq 0.5$	$N \leq 4$
			$0.5 < D$	NONE
		<p>NOTE : (1)POLARIZER BUBBLE IS DEFINED AS THE BUBBLE APPEARS ON ACTIVE DISPLAY AREA. THE DEFECT OF POLARIZER BUBBLE SHALL BE IGNORED IF THE POLARIZER BUBBLE APPEARS ON THE OUTSIDE OF ACTIVE DISPLAY AREA.</p> <p>(2)THE EXTRANEIOUS SUBSTANCE IS DEFINED AS IT CAN BE OBSERVED WHEN THE MODULE IS POWER ON.</p> <p>(3)THE DEFINITION OF AVERAGE DIAMETER, D IS DEFINED AS FOLLOWING.</p> <p>AVERAGE DIAMETER (D)=(a+b)/2</p> 		
8	LINE DEFECT ON DISPLAY	OBVIOUS VERTICAL OR HORIZONTAL LINE DEFECT IS NOT ALLOWED		
9	MURA ON DISPLAY	NOT VISIBLE THROUGH 5% ND FILTER OR JUDGED BY LIMIT SAMPLE IF NECESSARY.		
10	UNEVEN COLOR SPREAD, COLORATION	(1)TO BE DETERMINED BASED UPON THE STANDARD SAMPLE.		
11	BEZEL APPEARANCE	(1)BEZEL MAY NOT HAVE RUST, BE DEFORMED OR HAVE FINGER PRINTS STAINS OF OTHER CONTAMINATION. (2)BEZEL MUST COMPLY WITH JOB SPECIFICATIONS.		
12	PCB	(1)THERE MAY NOT BE MORE THAN 2mm OF SEALANT OUTSIDE THE SEAL AREA ON THE PCB, AND THERE SHOULD BE NO MORE THAN THREE PLACES. (2)NO OXIDATION OR CONTAMINATION PCB TERMINALS. (3)PARTS ON PCB MUST BE THE SAME AS ON THE PRODUCTION CHARACTERISTIC CHART. THERE SHOULD BE NO WRONG PARTS, MISSING PARTS OR EXCESS PARTS. (4)THE JUMPER ON THE PCB SHOULD CONFORM TO THE PRODUCT CHARACTERISTIC CHART. (5)IF SOLDER GETS ON BEZEL TAB PADS, LED PAD, ZEBRA PAD OR SCREW HOLD PAD; MAKE SURE IT IS SMOOTHED DOWN.		

### 13. RELIABILITY TEST

#### 13.1 STANDARD SPECIFICATIONS FOR RELIABILITY OF LCD MODULE

NO.	ITEM	DESCRIPTION
1	HIGH TEMPERATURE OPERATION	THE SAMPLE SHOULD BE ALLOWED TO STAND AT +70°C FOR 240 HRS
2	LOW TEMPERATURE OPERATION	THE SAMPLE SHOULD BE ALLOWED TO STAND AT -20°C FOR 240 HRS
3	HIGH TEMPERATURE STORAGE	THE SAMPLE SHOULD BE ALLOWED TO STAND AT +80°C FOR 240 HRS
4	LOW TEMPERATURE STORAGE	THE SAMPLE SHOULD BE ALLOWED TO STAND AT -30°C FOR 240 HRS
5	HIGH TEMPERATURE / HUMIDITY TEST (STORAGE)	THE SAMPLE SHOULD BE ALLOWED TO STAND AT 60°C, 90% RH 240 HRS
6	THERMAL SHOCK (NOT OPERATED)	<p>THE SAMPLE SHOULD BE ALLOWED TO STAND THE FOLLOWING 10 CYCLES OF OPERATION:</p>
7	ESD (ELECTROSTATIC DISCHARGE) (NOT OPERATED)	AIR DISCHARGE ± 12KV CONTACT DISCHARGE ± 8KV (ACCORDING TO IEC-61000-4-2)

NOTE ( 1 ) : THE TEST SAMPLES HAVE RECOVERY TIME FOR 2 HOURS AT ROOM TEMPERATURE BEFORE THE FUNCTION CHECK. IN THE STANDARD CONDITIONS, THERE IS NO DISPLAY FUNCTION NG ISSUE OCCURRED.

NOTE ( 2 ) : THERE IS NO DISPLAY FUNCTION NG ISSUE OCCURRED, ALL THE COSMETIC SPECIFICATION IS JUDGED BEFORE THE RELIABILITY STRESS.

NOTE ( 3 ) : THE MODULE SHOULDN'T BE TESTED MORE THAN ONE CONDITION, AND ALL THE TEST CONDITIONS ARE INDEPENDENT.

NOTE ( 4 ) : TESTING CONDITIONS AND INSPECTION CRITERIA

NO.	ITEM	TEST MODEL	INSPECTION CRITERIA
1	CURRENT CONSUMPTION	REFER TO SPECIFICATION	THE CURRENT CONSUMPTION SHOULD CONFORM TO THE PRODUCT SPECIFICATION.
2	CONTRAST	REFER TO SPECIFICATION	AFTER THE TESTS HAVE BEEN EXECUTED, THE CONTRAST MUST BE LARGER THAN HALF OF ITS INITIAL VALUE PRIOR TO THE TESTS.
3	APPEARANCE	VISUAL INSPECTION	DEFECT FREE

## 14. CAUTION

### 14.1 OPERATION

- 14.1.1 DO NOT CONNECT OR DISCONNECT MODULES TO OR FROM THE MAIN SYSTEM WHILE POWER IS BEING SUPPLIED .
- 14.1.2 USE THE MODULE WITHIN SPECIFIED TEMPERATURE ; LOWER TEMPERATURE CAUSES THE RETARDATION OF BLINKING SPEED OF THE DISPLAY ; HIGHER TEMPERATURE MAKES OVERALL DISPLAY DISCOLOR. WHEN THE TEMPERATURE RETURNS TO NORMALITY, THE DISPLAY WILL OPERATE NORMALLY .
- 14.1.3 ADJUST THE LC DRIVING VOLTAGE TO OBTAIN THE OPTIMUM CONTRAST.
- 14.1.4 POWER ON SEQUENCE INPUT SIGNALS SHOULD NOT BE SUPPLIED TO LCD MODULE BEFORE POWER SUPPLY VOLTAGE IS APPLIED AND REACHES THE SPECIFIED VALUE .  
IF ABOVE SEQUENCE IS NOT FOLLOWED , CMOS LSIS OF LCD MODULES MAY BE DAMAGED DUE TO LATCH - UP PROBLEM .
- 14.1.5 NOT ALLOWED TO INFLICT ANY EXTERNAL STRESS AND TO CAUSE ANY MECHANICAL INTERFERENCE ON THE BENDING AREA OF FPC DURING THE TAIL BENDING BACKWARDS!  
DO NOT STRESS FPC AND IC ON THE MODULE!

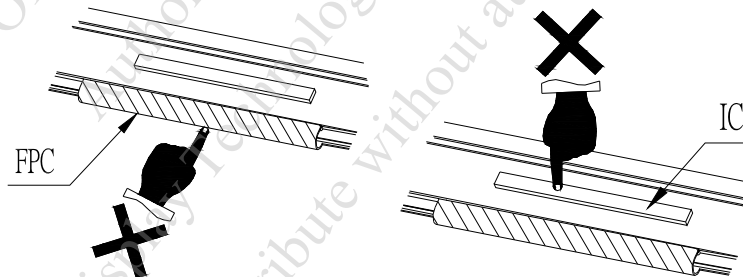

## 14.2 NOTICE

- 14.2.1 USE A GROUNDED SOLDERING IRON WHEN SOLDERING CONNECTOR I/O TERMINALS . FOR SOLDERING OR REPAIRING, TAKE PRECAUTION AGAINST THE TEMPERATURE OF THE SOLDERING IRON AND THE SOLDERING TIME TO PREVENT PEELING OFF THE THROUGH-HOLE-PAD .
- 14.2.2 DO NOT DISASSEMBLE . EDT SHALL NOT BE HELD RESPONSIBLE IF THE MODULE IS DISASSEMBLED AND UPON THE REASSEMBLY THE MODULE FAILED .
- 14.2.3 DO NOT CHARGE STATIC ELECTRICITY , AS THE CIRCUIT OF THIS MODULE CONTAINS CMOS LSIS. A WORKMAN'S BODY SHOULD ALWAYS BE STATIC-PROTECTED BY USE OF AN ESD STRAP. WORKING CLOTHES FOR SUCH PERSONNEL SHOULD BE OF STATIC-PROTECTED MATERIAL .
- 14.2.4 ALWAYS GROUND THE ELECTRICALLY-POWERED DRIVER BEFORE USING IT TO INSTALL THE LCD MODULE. WHILE CLEANING THE WORK STATION BY VACUUM CLEANER, DO NOT BRING THE SUCKING MOUTH NEAR THE MODULE ; STATIC ELECTRICITY OF THE ELECTRICALLY-POWERED DRIVER OR THE VACUUM CLEANER MAY DESTROY THE MODULE .
- 14.2.5 DON'T GIVE EXTERNAL SHOCK.
- 14.2.6 DON'T APPLY EXCESSIVE FORCE ON THE SURFACE.
- 14.2.7 LIQUID IN LCD IS HAZARDOUS SUBSTANCE. MUST NOT LICK AND SWALLOW.  
WHEN THE LIQUID IS ATTACH TO YOUR, SKIN, CLOTH ETC.  
WASH IT OUT THOROUGHLY AND IMMEDIATELY.
- 14.2.8 DON'T OPERATE IT ABOVE THE ABSOLUTE MAXIMUM RATING.
- 14.2.9 STORAGE IN A CLEAN ENVIRONMENT, FREE FROM DUST, ACTIVE GAS AND SOLVENT.
- 14.2.10 STORE WITHOUT ANY PHYSICAL LOAD.
- 14.2.11 REWIRING: NO MORE THAN 3 TIMES.