

EXAMINED BY :	EMERGING DISPLAY TECHNOLOGIES CORPORATION	FILE NO . CAS-0007989
<i>Justin Horng</i>		ISSUE : AUG.03, 2016
APPROVED BY :		TOTAL PAGE : 24
<i>Yung Chang Hu</i>		VERSION : 5

CUSTOMER ACCEPTANCE SPECIFICATIONS

MODEL NO. :
ET035009DS6
 (RoHS)
 FOR MESSRS :

CUSTOMER'S APPROVAL

DATE :

BY :

CONFIDENTIAL
 Approved for _____ Corporation Only.
 Emerging Display Technologies Corporation
 Do not distribute without authorization.

RECORDS OF REVISION

DOC . FIRST ISSUE
OCT.07, 2014

DATE	REVISED PAGE NO.	SUMMARY																								
NOV.27, 2014	4	<p>5.1 PIXEL TIMING</p> <table border="1"> <thead> <tr> <th>CHARACTERISTICS</th> <th>SYMBOL</th> <th>MIN.</th> <th>TYP.</th> <th>MAX.</th> <th>UNIT</th> </tr> </thead> <tbody> <tr> <td>PHASE DIFFERENCE OF SYNC SIGNAL FALLING EDGE</td> <td>thv</td> <td>-4</td> <td>—</td> <td>+4</td> <td>tDOTCLK</td> </tr> </tbody> </table> <p style="text-align: center;">↓</p> <table border="1"> <thead> <tr> <th>CHARACTERISTICS</th> <th>SYMBOL</th> <th>MIN.</th> <th>TYP.</th> <th>MAX.</th> <th>UNIT</th> </tr> </thead> <tbody> <tr> <td>PHASE DIFFERENCE OF SYNC SIGNAL FALLING EDGE</td> <td>thv</td> <td>1</td> <td>—</td> <td>240</td> <td>tDOTCLK</td> </tr> </tbody> </table>	CHARACTERISTICS	SYMBOL	MIN.	TYP.	MAX.	UNIT	PHASE DIFFERENCE OF SYNC SIGNAL FALLING EDGE	thv	-4	—	+4	tDOTCLK	CHARACTERISTICS	SYMBOL	MIN.	TYP.	MAX.	UNIT	PHASE DIFFERENCE OF SYNC SIGNAL FALLING EDGE	thv	1	—	240	tDOTCLK
CHARACTERISTICS	SYMBOL	MIN.	TYP.	MAX.	UNIT																					
PHASE DIFFERENCE OF SYNC SIGNAL FALLING EDGE	thv	-4	—	+4	tDOTCLK																					
CHARACTERISTICS	SYMBOL	MIN.	TYP.	MAX.	UNIT																					
PHASE DIFFERENCE OF SYNC SIGNAL FALLING EDGE	thv	1	—	240	tDOTCLK																					
	15~20	12. TOUCH PANEL SPECIFICATION → 12.INSPECTION CRITERION																								
JAN.20, 2015	7	<p>6.1 OPTICAL CHARACTERISTICS</p> <p>THE BRIGHTNESS OF MODULE: MIN.=600→800; TYP.=650→860</p>																								
APR.09, 2015	3	<p>4. ELECTRICAL CHARACTERISTICS</p> <p>NOTE(1) : INTERNAL CIRCUIT DIAGRAM OF BACKLIGHT</p> 																								
AUG.03, 2016	1	<p>2. MECHANICAL SPECIFICATIONS</p> <p>(9)VIEWING DIRECTION : ADD (GRAY LEVEL INVERSION)</p>																								
	2	<p>3.1 LCD MODULE ELECTRICAL ABSOLUTE MAXIMUM RATINGS</p> <p>LED BACKLIGHT DISSIPATION : MAX.=2677→4284</p> <p>LED BACKLIGHT CURRENT : MAX.=150→240</p>																								

TABLE OF CONTENTS

NO.	ITEM	PAGE
1.	GENERAL SPECIFICATIONS -----	1
2.	MECHANICAL SPECIFICATIONS -----	1
3.	ABSOLUTE MAXIMUM RATINGS -----	2
4.	ELECTRICAL CHARACTERISTICS -----	3
5.	TIMING CHART -----	4 ~ 6
6.	OPTICAL CHARACTERISTICS -----	7, 8
7.	OUTLINE DIMENSIONS -----	9
8.	BLOCK DIMENSIONS -----	10
9.	DETAIL DRAWING OF DOT MATRIX -----	11
10.	INTERFACE SIGNAL -----	12, 13
11.	POWER SUPPLY -----	14
12.	INSPECTION CRITERION -----	15 ~ 24

CONFIDENTIAL
Authorized for
Emerging Display Technologies Corporation Only.
Do not distribute without authorization.

1. GENERAL SPECIFICATIONS

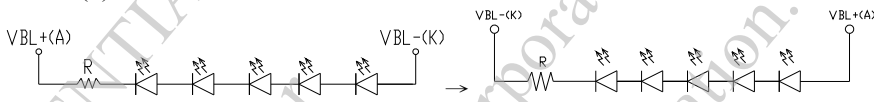
1.1 DATA SHEETS FOR CONTROLLER/DRIVER PLEASE REFER TO :

H X 8 2 3 8 - A

1.2 MATERIAL SAFETY DESCRIPTION

ASSEMBLIES SHALL COMPLY WITH EUROPEAN ROHS REQUIREMENTS, INCLUDING PROHIBITED MATERIALS/COMPONENTS CONTAINING LEAD, MERCURY, CADMIUM, HEXAVALENT CHROMIUM, POLYBROMINATED BIPHENYLS (PBB) AND POLYBROMINATED DIPHENYL ETHERS (PBDE)

2. MECHANICAL SPECIFICATIONS

(1) DIAGONALS	-----	3.5 inch
(2) NUMBER OF DOTS	-----	320W * (RGB) * 240H DOTS
(3) MODULE SIZE	-----	76.8W * 63.8H * 5.65(D) mm (WITHOUT FPC)
(4) ACTIVE AREA	-----	70.08W * 52.56H mm
(5) DOT SIZE	-----	0.073W * 0.219H mm
(6) PIXEL SIZE	-----	0.219W * 0.219H mm
(7) LCD TYPE	-----	TFT , TRANSMISSIVE
(8) COLOR	-----	262K
(9) VIEWING DIRECTION	-----	6 O'CLOCK (GRAY LEVEL INVERSION)
(10) BACK LIGHT	-----	LED , COLOR : WHITE
(11) INTERFACE MODE	-----	RGB 24BIT PARALLEL (DE/SYHC MODE)

3. ABSOLUTE MAXIMUM RATINGS

3.1 LCD MODULE ELECTRICAL ABSOLUTE MAXIMUM RATINGS

PARAMETER	SYMBOL	MIN.	MAX.	UNIT	REMARK
POWER VOLTAGE	VDD	VSS-0.3	5.0	V	—
	VCC	-0.3	4.0	V	—
LED BACKLIGHT DISSIPATION	PD	—	4284	mW	—
LED BACKLIGHT CURRENT	IF	—	240	mA	—
LED BACKLIGHT REVERSE VOLTAGE	VR	—	25	V	—

3.2 ENVIRONMENTAL ABSOLUTE MAXIMUM RATINGS

ITEM	OPERATING		STORAGE		REMARK
	MIN.	MAX.	MIN.	MAX.	
AMBIENT TEMPERATURE	-20°C	70°C	-30°C	80°C	NOTE (1), (2)
HUMIDITY	NOTE (3)		NOTE (3)		WITHOUT CONDENSATION
VIBRATION	—	2.45m/s ² (0.25G)	—	11.76m/s ² (1.2G)	5~20Hz , 1HR 20~500Hz(20Hz) , 1HR 20~500Hz(500Hz) , 1HR X,Y,Z,TOTAL 3HR
SHOCK	—	29.4m/s ² (3G)	—	490m/s ² (50G)	10 ms XYZ DIRECTIONS 1 TIME EACH
CORROSIVE GAS	NOT ACCEPTABLE		NOT ACCEPTABLE		

NOTE (1) : Ta AT -30°C : 48HR MAX.

80°C : 168HR MAX.

NOTE (2) : BACKGROUND COLOR CHANGES SLIGHTLY DEPENDING ON AMBIENT TEMPERATURE THIS PHENOMENON IS REVERSIBLE.

NOTE (3) : Ta ≤ 60°C : 90%RH MAX (96HRS MAX).

Ta > 60°C : ABSOLUTE HUMIDITY MUST BE LOWER THAN THE HUMIDITY OF 90%RH AT 60°C(96HRS MAX).

4. ELECTRICAL CHARACTERISTICS

Ta = 25 °C

PARAMETER	SYMBOL	CONDITION	MIN.	TYP.	MAX.	UNIT	REMARK
DIGITAL POWER SUPPLY	VCC	—	2.5	3.3	3.6	V	
ANALOG POWER SUPPLY	VDD	—	2.5	3.3	3.6	V	
DIGITAL OPERATING CURRENT	ICC	—	—	1	2	mA	
ANALOG OPERATING CURRENT	IDD	—	—	10	15	mA	
LOGIC HIGH OUTPUT VOLTAGE	VOH	IOUT=-100µA	0.9*VCC	—	VCC	V	
LOGIC LOW OUTPUT VOLTAGE	VOL	IOUT=100µA	0	—	0.1*VCC	V	
LOGIC HIGH INPUT VOLTAGE	VIH	H LEVEL	0.8*VCC	—	VCC	V	
LOGIC LOW INPUT VOLTAGE	VIL	L LEVEL	0	—	0.2*VCC	V	
POWER SUPPLY FOR LED BACKLIGHT	V _F	IF=40mA	13.65	—	17.85	V	NOTE (1)
LED LIFE TIME		I _{LED} =40mA (PER.LED)	70K	—	—	hr	NOTE(3) NOTE(4)

NOTE (1) : INTERNAL CIRCUIT DIAGRAM OF BACKLIGHT

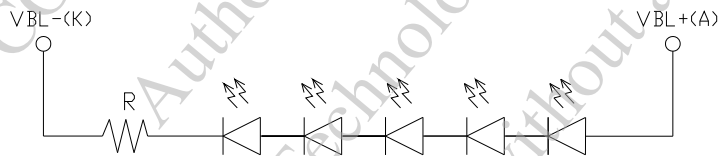

NOTE (2) : AMBIENT TEMP .VS. ALLOWABLE FORWARD CURRENT.(PER LED)

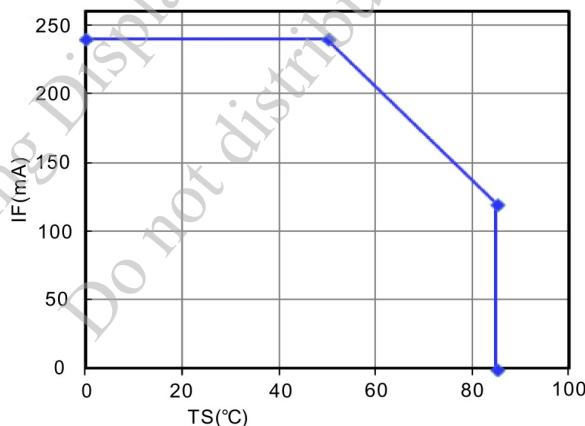

NOTE (3) : CONDITIONS; TA=25 °C, CONTINUOUS LIGHTING

NOTE (4) : DEFINITIONS OF FAILURE

- A. LCD LUMINANCE BECOMES HALF OF THE MINIMUM VALUE.
- B. LED DOESN'T LIGHT NORMALLY

5. TIMING CHART

5.1 PIXEL TIMING

CHARACTERISTICS	SYMBOL	MIN.	TYP.	MAX.	UNIT
DOTCLK FREQUENCY	fDOTCLK	—	6.5	10	MHz
DOTCLK PERIOD	tDOTCLK	100	154	—	ns
VERTICAL SYNC SETUP TIME	tvsys	20	—	—	ns
VERTICAL SYNC HOLD TIME	tvsyh	20	—	—	ns
HORIZONTAL SYNC SETUP TIME	thsys	20	—	—	ns
HORIZONTAL SYNC HOLD TIME	thsyh	20	—	—	ns
PHASE DIFFERENCE OF SYNC SIGNAL FALLING EDGE	thv	1	—	240	tDOTCLK
DOTCLK LOW PERIOD	tCKL	50	—	—	ns
DOTCLK HIGH PERIOD	tCKH	50	—	—	ns
DATA SETUP TIME	tds	12	—	—	ns
DATA HOLD TIME	tdh	12	—	—	ns
RESET PULSE WIDTH	tRES	10	—	—	μs

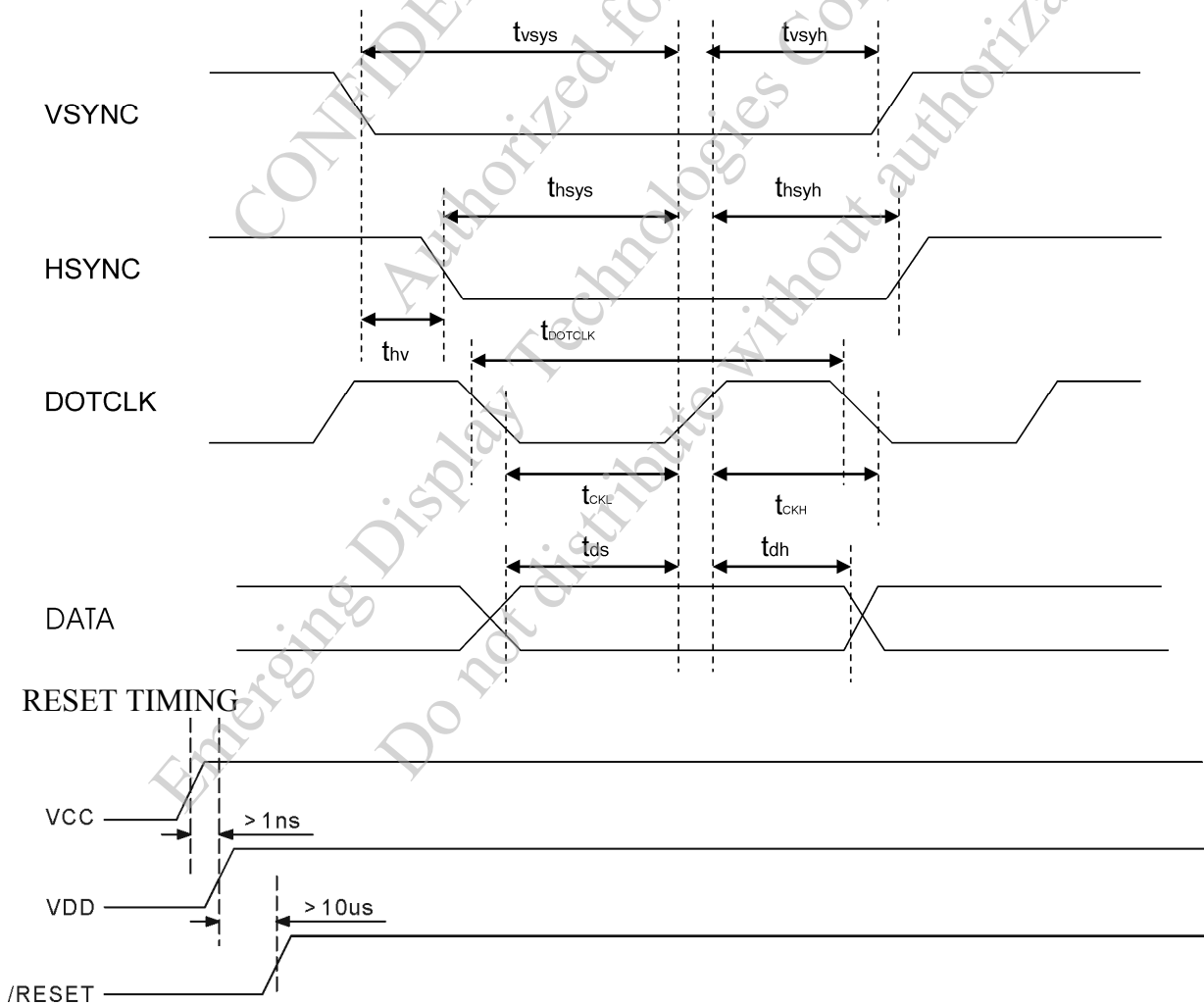

5.2 PARALLEL RGB INTERFACE (SYNC MODE)

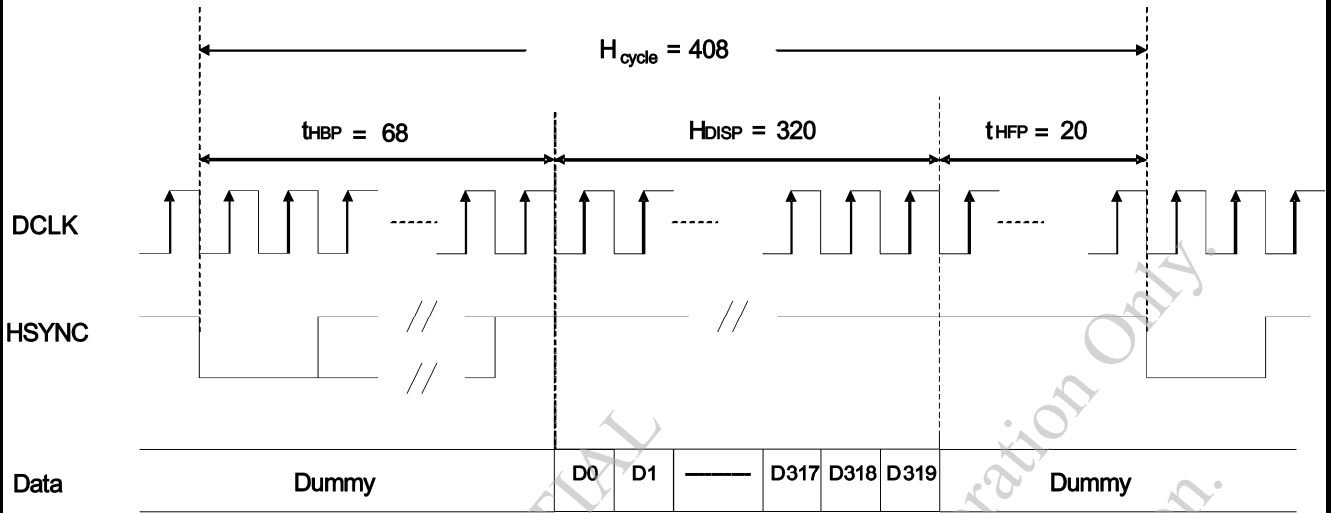

a) Horizontal Data Transaction Timing

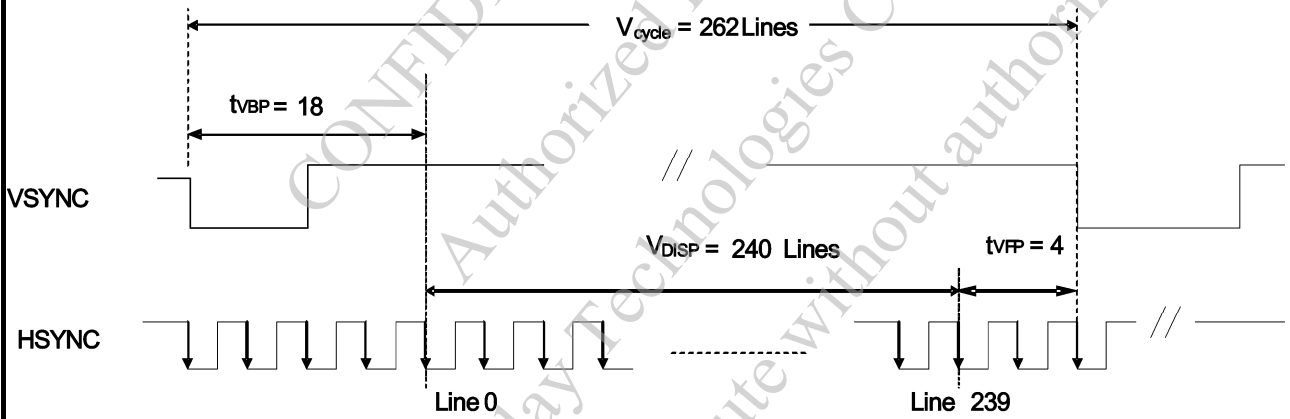

b) Vertical Data Transaction Timing

Parallel RGB Interface (DE Mode)

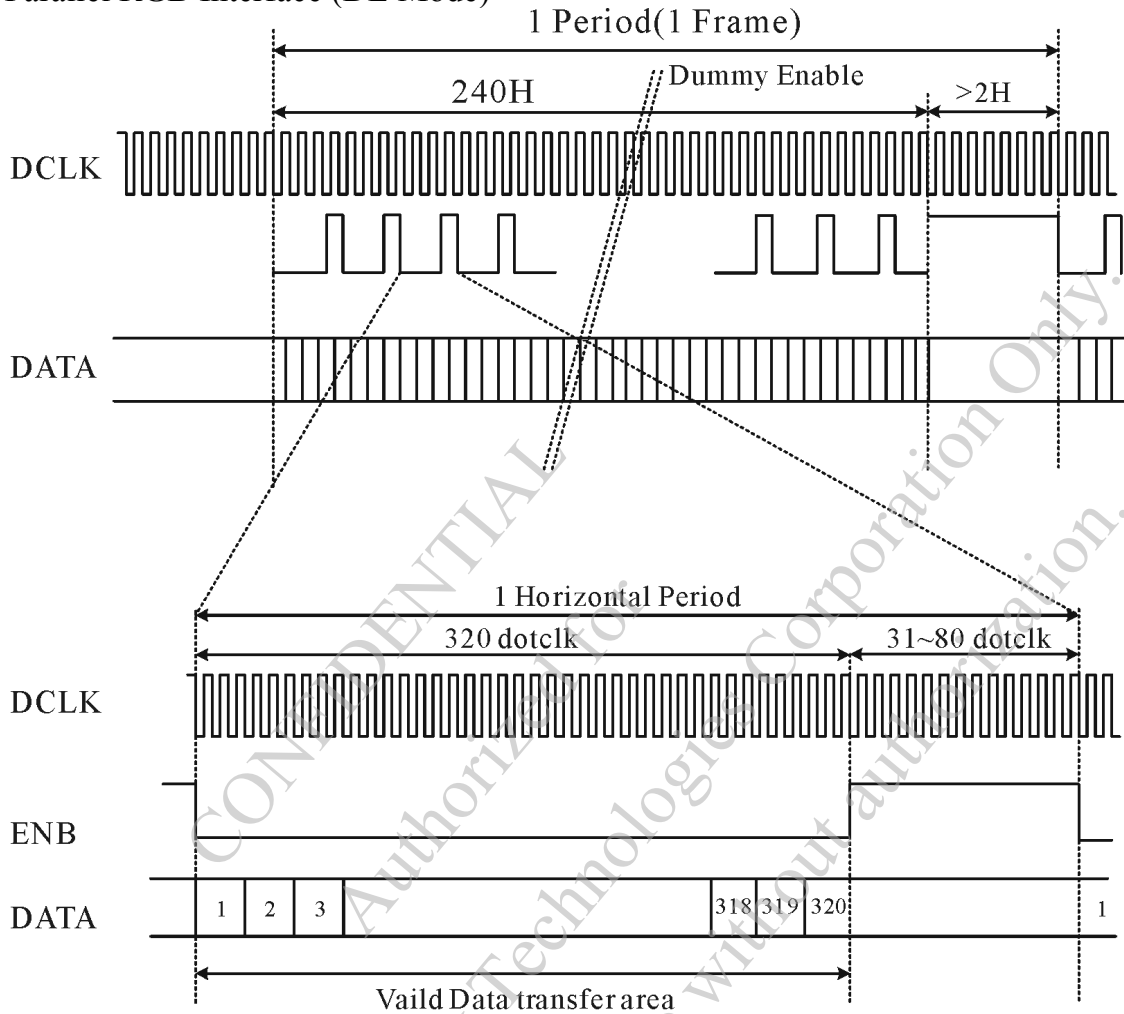

CHARACTERISTICS	SYMBOL	MIN.	TYP.	MAX.		
DCLK FREQUENCY	fDCLK	—	6.5	10	MHz	
DCLK PERIOD	tDCLK	100	154	—	ns	
HORIZONTAL FREQUENCY (LINE)	fH	—	15.72	22.35	KHz	
VERTICAL FREQUENCY (REFRESH)	fV	—	60	90	Hz	
HORIZONTAL BACK PORCH	tHBP	—	68	—	tDCLK	
HORIZONTAL FRONT PORCH	tHFP	—	20	—	tDCLK	
HORIZONTAL DATA START POINT	tHBP	—	68	—	tDCLK	
HORIZONTAL BLANKING PERIOD	tHBP + tHFP	—	88	—	tDCLK	
HORIZONTAL DISPLAY AREA	HDISP	—	320	—	tDCLK	
HORIZONTAL CYCLE	Hcycle	—	408	450	tDCLK	
VERTICAL BACK PORCH	tVBP	—	18	—	Lines	
VERTICAL FRONT PORCH	tVFP	—	4	—	Lines	
VERTICAL DATA START POINT	tVBP	—	18	—	Lines	
VERTICAL BLANKING PERIOD	tVBP + tVFP	—	22	—	Lines	
VERTICAL DISPLAY AREA	NTSC	VDISP	—	240	—	Lines
	PAL		—	280(PALM=0)	—	
VERTICAL CYCLE	NTSC	Vcycle	—	262	350	Lines
	PAL		—	313		

6. OPTICAL CHARACTERISTICS (NOTE1)

6.1 OPTICAL CHARACTERISTICS

Ta = 25 ± 2°C

I T E M		SYMBOL	CONDITION	MIN.	TYP.	MAX.	UNIT	REMARK	
VIEWING ANGLE		θ_{y+}	CR ≥ 10	50	55	—	deg.	(2), (3)	
		θ_{y-}		$\theta_x=0^\circ$	70	75			—
		θ_{x+}		$\theta_y=0^\circ$	70	75			—
		θ_{x-}			70	75			—
CONTRAST RATIO		CR	$\theta_x=0^\circ, \theta_y=0^\circ$	350	450	—		(3)	
RESPONSE TIME		T_R (rise)	$\theta_x=0^\circ, \theta_y=0^\circ$	—	15	20	msec	(4)	
		T_F (fall)		—	35	50			
THE BRIGHTNESS OF MODULE		B	$\theta_x=0^\circ, \theta_y=0^\circ$ IF=40mA	800	860	—	cd/m ²	(5)	
COLOR OF CIE COORDINATE	WHITE	W_x	$\theta_x=0^\circ, \theta_y=0^\circ$ NTSC : 60% IF=40mA	0.25	0.31	0.37	—	(6)	
		W_y		0.28	0.35	0.42			
	RED	R_x		0.58	0.63	0.68			
		R_y		0.31	0.36	0.41			
	GREEN	G_x		0.28	0.33	0.38			
		G_y		0.58	0.63	0.68			
	BLUE	B_x		0.09	0.14	0.19			
		B_y		0.095	0.145	0.195			
THE UNIFORMITY OF BRIGHTNESS		—	—	70	75	—	%	—	

NOTE (1) : TEST EQUIPMENT SETUP :

AFTER STABILIZING AND LEAVING THE PANEL ALONE AT A GIVEN TEMPERATURE FOR 30 MINUTES. MEASUREMENT SHOULD BE EXECUTED IN A STABLE, WINDLESS, AND DARK ROOM. OPTICAL SPECIFICATIONS ARE MEASURED BY TOPCON BM-7 (FAST) WITH A VIEWING ANGLE OF 1° AT A DISTANCE OF 50cm AND NORMAL DIRECTION.

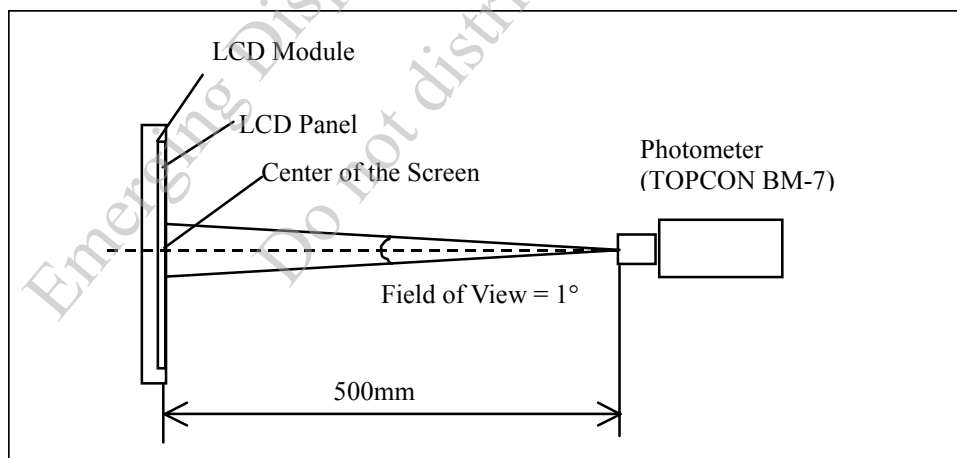

NOTE (2) : DEFINITION OF VIEWING ANGLE :

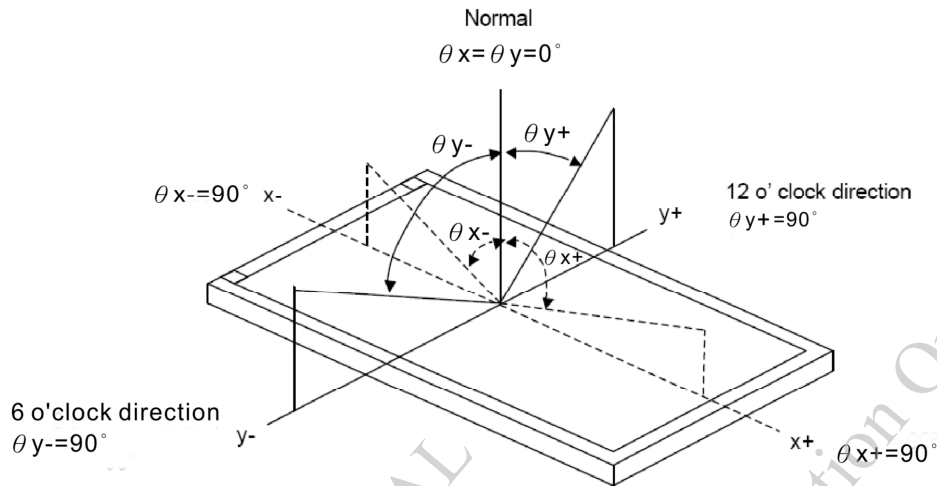

NOTE (3) : DEFINITION OF CONTRAST RATIO :

$$\text{CONTRAST RATIO (CR)} = \frac{\text{BRIGHTNESS MEASURED WHEN LCD IS AT "WHITE STATE"}}{\text{BRIGHTNESS MEASURED WHEN LCD IS AT "BLACK STATE"}}$$

NOTE (4) : DEFINITION OF RESPONSE TIME : TR AND TF

THE FIGURE BELOW IS THE OUTPUT SIGNAL OF THE PHOTO DETECTOR.

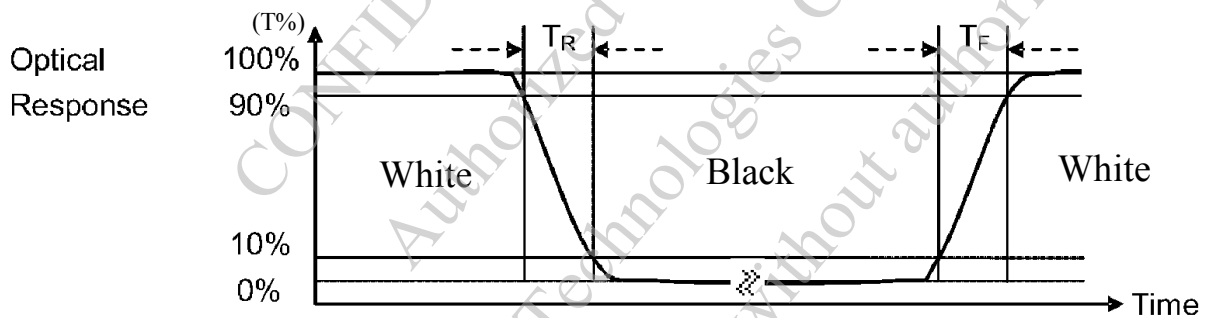

NOTE (5) : BRIGHTNESS MEASURED WHEN LCD IS AT "WHITE STATE"

NOTE (6) : THE 100% TRANSMISSION IS DEFINED AS THE TRANSMISSION OF LCD PANEL WHEN ALL THE INPUT TERMINALS OF MODULE ARE ELECTRICALLY OPENED.

6.2 THE TEST METHOD OF BRIGHTNESS AND UNIFORMITY

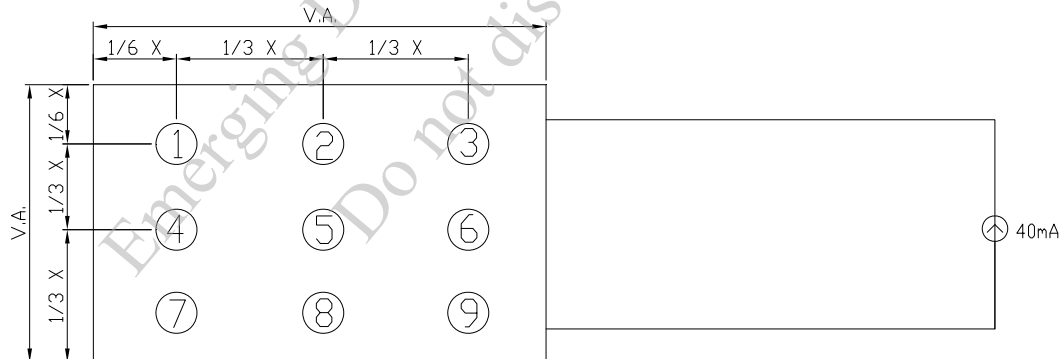

UNIT : mm

6.3 THE CALCULATING METHOD OF UNIFORMITY

$$\text{UNIFORMITY} = \left[1 - \frac{\text{MAXIMUM BRIGHTNESS} - \text{MINIMUM BRIGHTNESS}}{\text{AVERAGE BRIGHTNESS}} \right] \times 100\%$$

7. OUTLINE DIMENSIONS

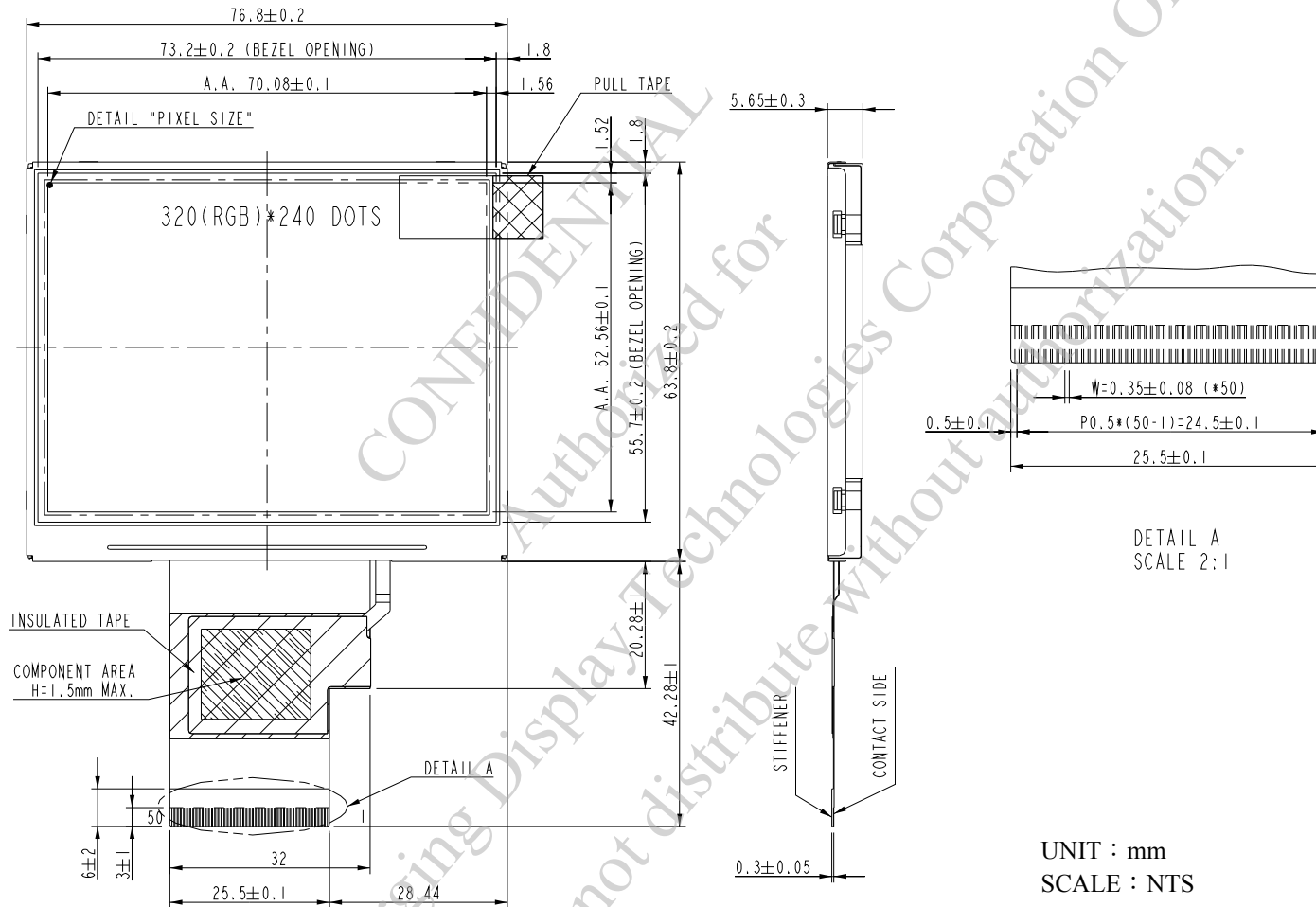

UNIT : mm
SCALE : NTS
NOTE : RECOMMEND MATCH CONNECTOR
KYOCERA : 04 6299 050 SERIES
NOT SPECIFIED LENGTH TOLERANCE IS ± 0.5

8. BLOCK DIMENSION

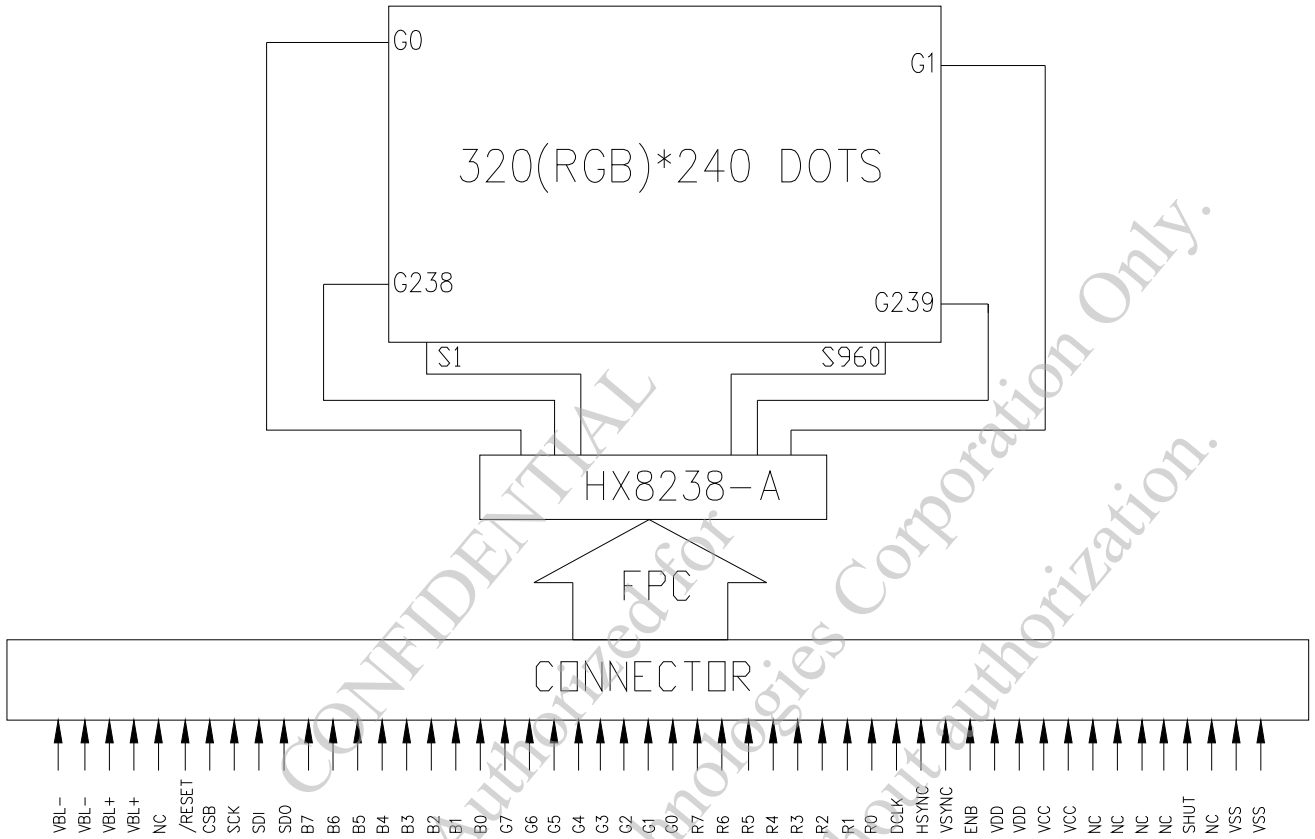

CONFIDENTIAL
Authorized for
Emerging Display Technologies Corporation Only.
Do not distribute without authorization.

9. DETAIL DRAWING OF DOT MATRIX

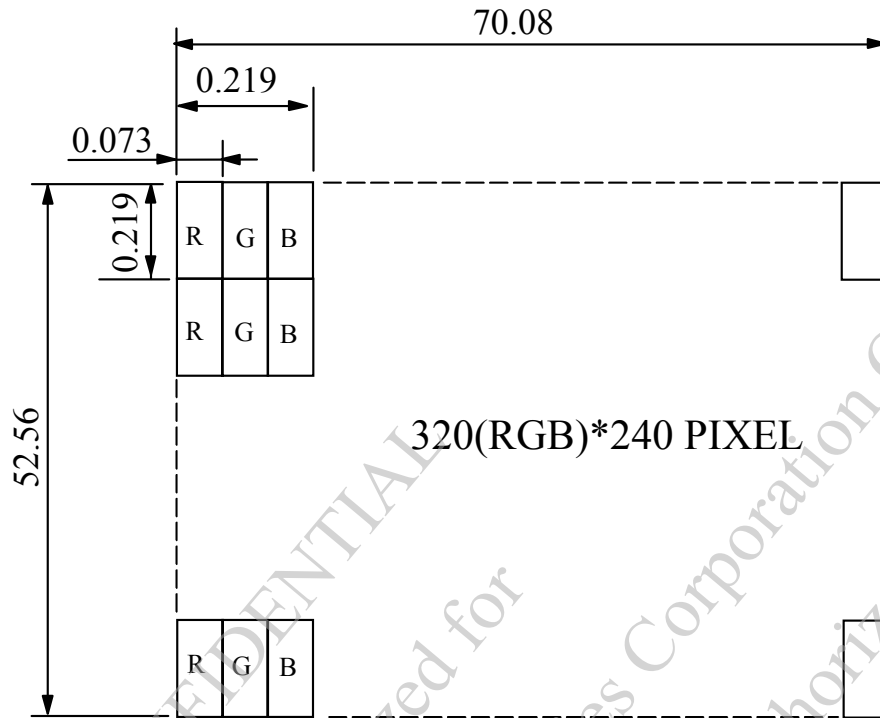

UNIT : mm
SCALE : NTS
NOT SPECIFIED TOLERANCE IS ± 0.1
DOTS MATRIX TOLERANCE IS ± 0.01

CONFIDENTIAL
 Authorized for Emerging Display Technologies Corporation Only.
 Do not distribute without authorization.

10. INTERFACE SIGNALS

PIN NO.	SYMBOL	I/O	FUNCTION
1	VBL-	P	BACKLIGHT LED GROUND (K)
2	VBL-	P	BACKLIGHT LED GROUND (K)
3	VBL+	P	BACKLIGHT LED POWER (A)
4	VBL+	P	BACKLIGHT LED POWER (A)
5	NC	—	NOT USE
6	/RESET	I	HARDWARE RESET
7	CSB	I	SPI INTERFACE CHIP SELECT BAR
8	SCK	I	SPI INTERFACE DATA CLOCK
9	SDI	I	SPI INTERFACE DATA (INPUT)
10	SDO	O	SPI INTERFACE DATA(OUTPUT)
11	B7	I	BLUE DATA BIT 7
12	B6	I	BLUE DATA BIT 6
13	B5	I	BLUE DATA BIT 5
14	B4	I	BLUE DATA BIT 4
15	B3	I	BLUE DATA BIT 3
16	B2	I	BLUE DATA BIT 2
17	B1	I	BLUE DATA BIT 1
18	B0	I	BLUE DATA BIT 0
19	G7	I	GREEN DATA BIT 7
20	G6	I	GREEN DATA BIT 6
21	G5	I	GREEN DATA BIT 5
22	G4	I	GREEN DATA BIT 4
23	G3	I	GREEN DATA BIT 3
24	G2	I	GREEN DATA BIT 2
25	G1	I	GREEN DATA BIT 1
26	G0	I	GREEN DATA BIT 0
27	R7	I	RED DATA BIT 7
28	R6	I	RED DATA BIT 6
29	R5	I	RED DATA BIT 5
30	R4	I	RED DATA BIT 4
31	R3	I	RED DATA BIT 3
32	R2	I	RED DATA BIT 2
33	R1	I	RED DATA BIT 1
34	R0	I	RED DATA BIT 0

PIN NO.	SYMBOL	I/O	FUNCTION
35	DCLK	I	DOT DATA CLOCK
36	HSYNC	I	HORIZONTAL SYNC INPUT
37	VSYNC	I	VERTICAL SYNC INPUT
38	ENB	I	DATA ENABLE INPUT
39	VDD	P	ANALOG POWER
40	VDD	P	ANALOG POWER
41	VCC	P	DIGITAL POWER
42	VCC	P	DIGITAL POWER
43	NC	—	NOT USE
44	NC	—	NOT USE
45	NC	—	NOT USE
46	NC	—	NOT USE
47	SHUT	I	DISPLAY SHUT DOWN PIN TO PUT THE DRIVER INTO SLEEP MODE. CONNECT TO VCC FOR SLEEP MODE. CONNECT TO VSS FOR NORMAL OPERATING MODE.
48	NC	—	NOT USE
49	VSS	P	GROUND
50	VSS	P	GROUND

CONFIDENTIAL
Authorized for Emerging Display Technologies Corporation Only.
Do not distribute without authorization.

11. POWER SUPPLY

11.1 POWER SUPPLY FOR LCM

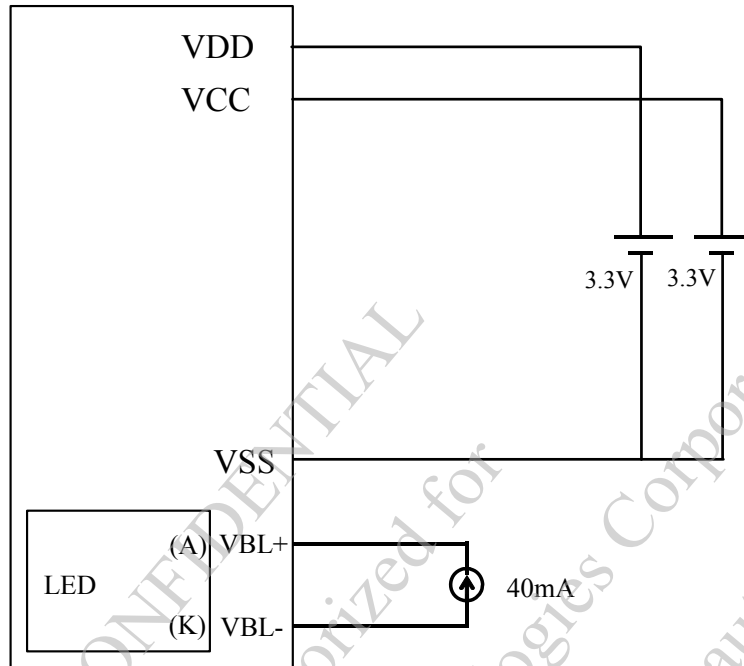

CONFIDENTIAL
Authorized for
Emerging Display Technologies Corporation Only.
Do not distribute without authorization.

12. INSPECTION CRITERION

12.1 APPLICATION

This inspection standard is to be applied to the LCD module delivered from EMERGING DISPLAY TECHNOLOGIES CORP.(E.D.T) to customers

12.2 INSPECTION CONDITIONS

12.2.1 (1)Observation Distance : 35cm±5cm

(2)View Angle :

Non-operation Condition : ±5°(perpendicular to LCD panel surface)

Operation Condition : ±45° (perpendicular to LCD panel surface)

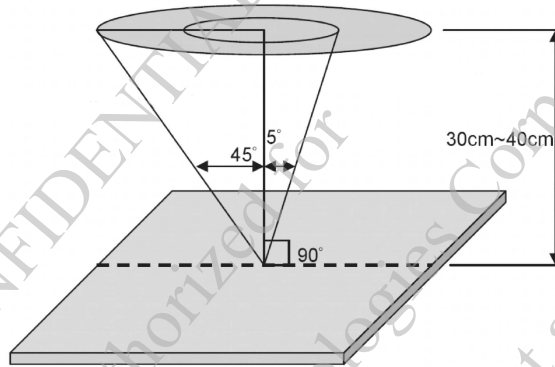

12.2.2 Environment Conditions :

Ambient Temperature		20°C~25°C
Ambient Humidity		65±20%RH
Ambient Illumination	Cosmetic Inspection	More than 600Lux
	Functional Inspection	300~500 Lux

12.2.3 Inspection lot

Quantity per delivery lot for each model

12.2.4 Inspection method

A sampling inspection shall be made according to the following provisions to judge The acceptability

(a)Applicable standard : MIL-STD-105E

Normal inspection , single sampling

Level II

(b)AQL : Major defect : AQL 0.65

Minor defect : AQL 1.0

12.3 INSPECTION STANDARDS

12.3.1 VISUAL DEFECTS CLASSIFICATION

TYPE OF DEFECT	INSPECTION ITEM	DEFECT FEATURE	AQL
MAJOR DEFECT	1.DISPLAY ON	<ul style="list-style-type: none"> • DEFECT TO MISS SPECIFIED DISPLAY FUNCTION, FOR ALL AND SPECIFIED DOTS EX: DISCONNECTION, SHORT CIRCUIT ETC 	0.65
	2.BACKLIGHT	<ul style="list-style-type: none"> • NO LIGHT • FLICKERING AND OTHER ABNORMAL ILLUMINATION 	
	3.DIMENSIONS	<ul style="list-style-type: none"> • SUBJECT TO INDIVIDUAL ACCEPTANCE SPECIFICATIONS 	
MINOR DEFECT	1.DISPLAY ZONE	<ul style="list-style-type: none"> • BLACK/WHITE SPOT • BUBBLES ON POLARIZER • NEWTON RING • BLACK/WHITE LINE • SCRATCH • CONTAMINATION • LEVER COLOR SPREAD 	1.0
	2.BEZEL ZONE	<ul style="list-style-type: none"> • STAINS • SCRATCHES • FOREIGN MATTER 	
	3.SOLDERING	<ul style="list-style-type: none"> • INSUFFICIENT SOLDER • SOLDERED IN INCORRECT POSITION • CONVEX SOLDERING SPOT • SOLDER BALLS • SOLDER SCRAPS 	
	4.DISPLAY ON (ALL ON)	<ul style="list-style-type: none"> • LIGHT LINE 	

12.3.2 MODULE DEFECTS CLASSIFICATION

NO.	ITEM	CRITERIA												
1.	DISPLAY ON INSPECTION	(1)INCORRECT PATTERN (2)MISSING SEGMENT (3)DIM SEGMENT (4)OPERATING VOLTAGE BEYOND SPEC												
2.	OVERALL DIMENSIONS	(1)OVERALL DIMENSION BEYOND SPEC												
3.	DOT DEFECT	(1) INSPECTION PATTERN: FULL WHITE, FULL BLACK, RED, GREEN AND BLUE SCREENS. (2) <table border="1" style="margin-left: 20px;"> <thead> <tr> <th>ITEMS</th> <th>ACCEPTABLE COUNT</th> </tr> </thead> <tbody> <tr> <td>BRIGHT DOT</td> <td>$N \leq 2$</td> </tr> <tr> <td>DARK DOT</td> <td>$N \leq 3$</td> </tr> <tr> <td>TOTAL BRIGHT AND DARK DOTS</td> <td>$N \leq 4$</td> </tr> </tbody> </table> <p>NOTE :</p> <p>1. THE DEFINITION OF DOT : THE SIZE OF A DEFECTIVE DOT OVER 1/2 OF WHOLE DOT IS REGARDED AS ONE DEFECTIVE DOT.</p> <p>2. BRIGHT DOT : DOTS APPEAR BRIGHT AND UNCHANGED IN SIZE IN WHICH LCD PANEL IS DISPLAYING UNDER BLACK PATTERN.</p> <p>3. DARK DOT : DOTS APPEAR DARK AND UNCHANGED IN SIZE IN WHICH LCD PANEL IS DISPLAYING UNDER PURE RED, GREEN, BLUE PICTURE.</p>	ITEMS	ACCEPTABLE COUNT	BRIGHT DOT	$N \leq 2$	DARK DOT	$N \leq 3$	TOTAL BRIGHT AND DARK DOTS	$N \leq 4$				
ITEMS	ACCEPTABLE COUNT													
BRIGHT DOT	$N \leq 2$													
DARK DOT	$N \leq 3$													
TOTAL BRIGHT AND DARK DOTS	$N \leq 4$													
4.	FOREIGN BLACK/WHITE/ BRIGHT LINE/ SCRATCH OF VIEWING AREA	<table border="1" style="margin-left: 20px;"> <thead> <tr> <th>LENGTH : L</th> <th>WIDTH : W</th> <th>PERMISSIBLE NO.</th> </tr> </thead> <tbody> <tr> <td>$L \leq 0.3$</td> <td>$W \leq 0.05$</td> <td>IGNORE</td> </tr> <tr> <td>$0.3 < L \leq 2.5$</td> <td>$0.05 < W \leq 0.1$</td> <td>4</td> </tr> <tr> <td>$2.5 < L$</td> <td>$0.1 < W$</td> <td>NONE</td> </tr> </tbody> </table> <p>WIDTH : W mm, LENGTH : L mm</p>	LENGTH : L	WIDTH : W	PERMISSIBLE NO.	$L \leq 0.3$	$W \leq 0.05$	IGNORE	$0.3 < L \leq 2.5$	$0.05 < W \leq 0.1$	4	$2.5 < L$	$0.1 < W$	NONE
LENGTH : L	WIDTH : W	PERMISSIBLE NO.												
$L \leq 0.3$	$W \leq 0.05$	IGNORE												
$0.3 < L \leq 2.5$	$0.05 < W \leq 0.1$	4												
$2.5 < L$	$0.1 < W$	NONE												
5.	FOREIGN MATTER \ BLACK SPOTS \ WHITE SPOTS \ DENT (INCLUDING LIGHT LEAKAGE DUE TO POLARIZING PLATES PINHOLES, ETC.)	<table border="1" style="margin-left: 20px;"> <thead> <tr> <th>AVERAGE DIAMETER (mm): D</th> <th>NUMBER OF PIECES PERMITTED</th> </tr> </thead> <tbody> <tr> <td>$D \leq 0.15$</td> <td>IGNORE</td> </tr> <tr> <td>$0.15 < D \leq 0.5$</td> <td>4</td> </tr> <tr> <td>$0.5 < D$</td> <td>NONE</td> </tr> </tbody> </table> <p>NOTE : DIAMETER $D=(a+b)/2$</p> 	AVERAGE DIAMETER (mm): D	NUMBER OF PIECES PERMITTED	$D \leq 0.15$	IGNORE	$0.15 < D \leq 0.5$	4	$0.5 < D$	NONE				
AVERAGE DIAMETER (mm): D	NUMBER OF PIECES PERMITTED													
$D \leq 0.15$	IGNORE													
$0.15 < D \leq 0.5$	4													
$0.5 < D$	NONE													

NO.	ITEM	CRITERIA		
			AVERAGE DIAMETER (mm) : D	NUMBER OF PIECES PERMITTED
6.	BUBBLES OF POLARIZER /DIRT/CF FAIL /SURFACE STAINS	BUBBLE ON THE POLARIZER	$D \leq 0.25$	IGNORE
			$0.25 < D \leq 0.5$	$N \leq 5$
			$0.5 < D$	NONE
		SURFACE STAINS	$D < 0.1 \text{ mm}$	IGNORE
			$0.1 < D \leq 0.3 \text{ mm}$	$N \leq 3$
		CF FAIL / SPOT	$D < 0.1 \text{ mm}$	IGNORE
$0.1 < D \leq 0.3 \text{ mm}$	$N \leq 3$			
		<p>NOTE : (1)POLARIZER BUBBLE IS DEFINED AS THE BUBBLE APPEARS ON ACTIVE DISPLAY AREA. THE DEFECT OF POLARIZER BUBBLE SHALL BE IGNORED IF THE POLARIZER BUBBLE APPEARS ON THE OUTSIDE OF ACTIVE DISPLAY AREA.</p> <p>(2)THE EXTRANEIOUS SUBSTANCE IS DEFINED AS IT CAN BE OBSERVED WHEN THE MODULE IS POWER ON.</p> <p>(3)THE DEFINITION OF AVERAGE DIAMETER, D IS DEFINED AS FOLLOWING.</p> <p>AVERAGE DIAMETER (D)=(a+b)/2</p> 		
7.	LINE DEFECT ON DISPLAY	OBVIOUS VERTICAL OR HORIZONTAL LINE DEFECT IS NOT ALLOWED		
8.	MURA ON DISPLAY	IT'S OK IF MURA IS SLIGHT VISIBLE THROUGH 6% ND FILTER		
9.	UNEVEN COLOR SPREAD, COLORATION	(1)TO BE DETERMINED BASED UPON THE STANDARD SAMPLE.		
10.	BEZEL APPEARANCE	(1)BEZEL MAY NOT HAVE RUST, BE DEFORMED OR HAVE FINGER PRINTS STAINS OF OTHER CONTAMINATION. (2)BEZEL MUST COMPLY WITH JOB SPECIFICATIONS.		
11.	PCB	<p>(1)THERE MAY NOT BE MORE THAN 2mm OF SEALANT OUTSIDE THE SEAL AREA ON THE PCB, AND THERE SHOULD BE NO MORE THAN THREE PLACES.</p> <p>(2)NO OXIDATION OR CONTAMINATION PCB TERMINALS.</p> <p>(3)PARTS ON PCB MUST BE THE SAME AS ON THE PRODUCTION CHARACTERISTIC CHART. THERE SHOULD BE NO WRONG PARTS, MISSING PARTS OR EXCESS PARTS.</p> <p>(4)THE JUMPER ON THE PCB SHOULD CONFORM TO THE PRODUCT CHARACTERISTIC CHART.</p> <p>(5)IF SOLDER GETS ON BEZEL TAB PADS, LED PAD, ZEBRA PAD OR SCREW HOLD PAD, MAKE SURE IT IS SMOOTHED DOWN.</p>		

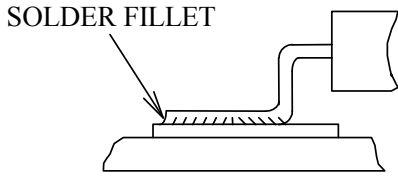
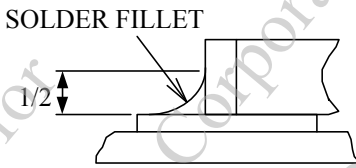
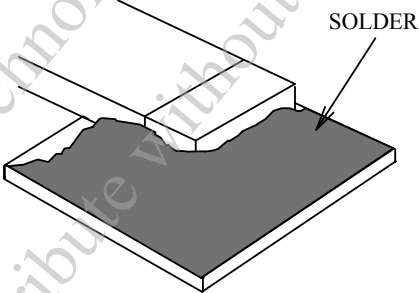
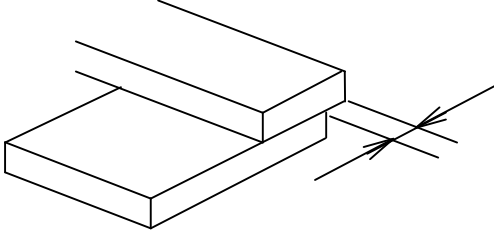
NO.	ITEM	CRITERIA
12.	SOLDERING	<p>(1) NO SOLDERING FOUND ON THE SPECIFIED PLACE</p> <p>(2) INSUFFICIENT SOLDER</p> <p>(a) LSI, IC A POOR WETTING OF SOLDER IS BETWEEN LOWER BEND OR "HEEL" OF LEAD AND PAD</p>  <p>(b) CHIP COMPONENT</p> <ul style="list-style-type: none"> · SOLDER IS LESS THAN 50% OF SIDES AND FRONT FACE WETTING  <ul style="list-style-type: none"> · SOLDER WETS 3 SIDES OF TERMINAL, BUT LESS THAN 25% OF SIDES AND FRONT SURFACE AREA ARE COVERED  <p>(3) PARTS ALIGNMENT</p> <p>(a) LSI, IC LEAD WIDTH IS MORE THAN 50% BEYOND PAD OUTLINE</p> 

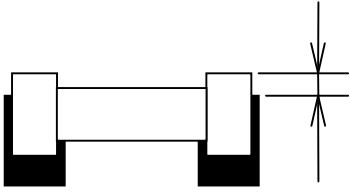
NO.	ITEM	CRITERIA
12.	SOLDERING	<p>(b)CHIP COMPONENT COMPONENT IS OFF CENTER, AND MORE THAN 50% OF THE LEADS IS OFF THE PAD OUTLINE</p>  <p>(4)NO UNMELTED SOLDER PASTE MAY BE PRESENT ON THE PCB. (5)NO COLD SOLDER JOINTS, MISSING SOLDER CONNECTIONS, OXIDATION OR ICICLE. (6)NO RESIDUE OR SOLDER BALLS ON PCB. (7)NO SHORT CIRCUITS IN COMPONENTS ON PCB.</p>
13.	BACKLIGHT	<p>(1)NO LIGHT (2)FLICKERING AND OTHER ABNORMAL ILLUMINATION (3)SPOTS OR SCRATCHES THAT APPEAR WHEN LIT MUST BE JUDGED USING LCD SPOT, LINES AND CONTAMINATION STANDARDS. (4)BACKLIGHT DOESN'T LIGHT OR COLOR IS WRONG.</p>
14.	GENERAL APPEARANCE	<p>(1)NO OXIDATION, CONTAMINATION, CURVES OR, BENDS ON INTERFACE PIN (OLB) OF TCP. (2)NO CRACKS ON INTERFACE PIN (OLB) OF TCP. (3)NO CONTAMINATION, SOLDER RESIDUE OR SOLDER BALLS ON PRODUCT. (4)THE IC ON THE TCP MAY NOT BE DAMAGED, CIRCUITS. (5)THE UPPERMOST EDGE OF THE PROTECTIVE STRIP ON THE INTERFACE PIN MUST BE PRESENT OR LOOK AS IF IT CAUSE THE INTERFACE PIN TO SEVER. (6)THE RESIDUAL ROSIN OR TIN OIL OF SOLDERING (COMPONENT OR CHIP COMPONENT) IS NOT BURNED INTO BROWN OR BLACK COLOR. (7)SEALANT ON TOP OF THE ITO CIRCUIT HAS NOT HARDENED. (8)PIN TYPE MUST MATCH TYPE IN SPECIFICATION SHEET. (9)LCD PIN LOOSE OR MISSING PINS. (10)PRODUCT PACKAGING MUST THE SAME AS SPECIFIED ON PACKAGING SPECIFICATION SHEET. (11)PRODUCT DIMENSION AND STRUCTURE MUST CONFORM TO PRODUCT SPECIFICATION SHEET. (12)THE APPEARANCE OF HEAT SEAL SHOULD NOT ADMIT ANY DIRT AND BREAK.</p>

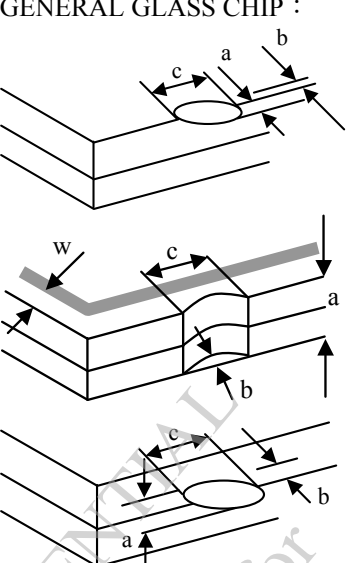
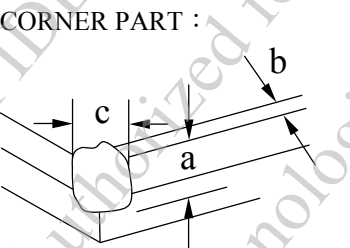
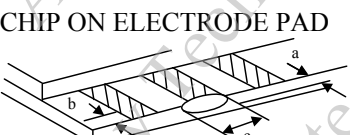
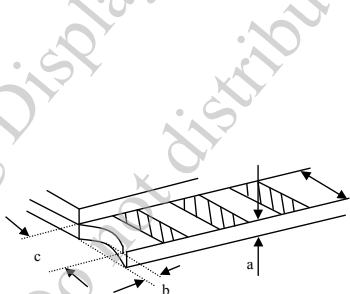
NO.	ITEM	CRITERIA									
15.	CRACKED GLASS	<p>THE LCD WITH EXTENSIVE CRACK IS NOT ACCEPTABLE</p>									
		<p>GENERAL GLASS CHIP :</p>  <table border="1" data-bbox="933 369 1460 459"> <thead> <tr> <th>a</th> <th>b</th> <th>c</th> </tr> </thead> <tbody> <tr> <td>$\leq t/2$</td> <td>< VIEWING AREA</td> <td>$\leq 1/8X$</td> </tr> <tr> <td>$t/2 > , \leq 2t$</td> <td>$\leq W/2$</td> <td>$\leq 1/8X$</td> </tr> </tbody> </table> <p>*W=DISTANCE BETWEEN SEALANT AREA AND LCD PANEL EDGE X = LCD SIDE LENGTH t = GLASS THICKNESS</p>	a	b	c	$\leq t/2$	< VIEWING AREA	$\leq 1/8X$	$t/2 > , \leq 2t$	$\leq W/2$	$\leq 1/8X$
		a	b	c							
		$\leq t/2$	< VIEWING AREA	$\leq 1/8X$							
$t/2 > , \leq 2t$	$\leq W/2$	$\leq 1/8X$									
<p>CORNER PART :</p>  <table border="1" data-bbox="933 958 1460 1048"> <thead> <tr> <th>a</th> <th>b</th> <th>c</th> </tr> </thead> <tbody> <tr> <td>$\leq t/2$</td> <td>< VIEWING AREA</td> <td>$\leq 1/8X$</td> </tr> <tr> <td>$> t/2 , \leq 2t$</td> <td>$\leq W/2$</td> <td>$\leq 1/8X$</td> </tr> </tbody> </table> <p>*W=DISTANCE BETWEEN SEALANT AREA AND LCD PANEL EDGE X = LCD SIDE LENGTH t = GLASS THICKNESS</p>	a	b	c	$\leq t/2$	< VIEWING AREA	$\leq 1/8X$	$> t/2 , \leq 2t$	$\leq W/2$	$\leq 1/8X$		
a	b	c									
$\leq t/2$	< VIEWING AREA	$\leq 1/8X$									
$> t/2 , \leq 2t$	$\leq W/2$	$\leq 1/8X$									
<p>CHIP ON ELECTRODE PAD</p>  <table border="1" data-bbox="933 1232 1460 1288"> <thead> <tr> <th>a</th> <th>b</th> <th>c</th> </tr> </thead> <tbody> <tr> <td>$\leq t$</td> <td>$\leq 0.5\text{mm}$</td> <td>$\leq 1/8X$</td> </tr> </tbody> </table> <p>* X=LCD SIDE WIDTH t=GLASS THICKNESS</p>	a	b	c	$\leq t$	$\leq 0.5\text{mm}$	$\leq 1/8X$					
a	b	c									
$\leq t$	$\leq 0.5\text{mm}$	$\leq 1/8X$									
 <table border="1" data-bbox="933 1388 1460 1444"> <thead> <tr> <th>a</th> <th>b</th> <th>c</th> </tr> </thead> <tbody> <tr> <td>$\leq t$</td> <td>$\leq 1/8X$</td> <td>$\leq L$</td> </tr> </tbody> </table> <p>*X=LCD SIDE WIDTH t = GLASS THICKNESS L=ELECTRODE PAD LENGTH ①IF GLASS CHIPPING THE ITO TERMINAL, OVER 2/3 OF THE ITO MUST REMAIN AND BE, INSPECTED ACCORDING TO ELECTRODE TERMINAL SPECIFICATIONS ②IF THE PRODUCT WILL BE HEAT SEALED BY THE CUSTOMER, THE ALIGNMENT MARK MUST NOT BE DAMAGED</p>	a	b	c	$\leq t$	$\leq 1/8X$	$\leq L$					
a	b	c									
$\leq t$	$\leq 1/8X$	$\leq L$									

12.4 RELIABILITY TEST

12.4.1 STANDARD SPECIFICATIONS FOR RELIABILITY OF LCD MODULE

NO.	ITEM	DESCRIPTION
1	HIGH TEMPERATURE OPERATION	THE SAMPLE SHOULD BE ALLOWED TO STAND AT +70°C FOR 240 HRS
2	LOW TEMPERATURE OPERATION	THE SAMPLE SHOULD BE ALLOWED TO STAND AT -20°C FOR 240 HRS
3	HIGH TEMPERATURE STORAGE	THE SAMPLE SHOULD BE ALLOWED TO STAND AT +80°C FOR 240 HRS
4	LOW TEMPERATURE STORAGE	THE SAMPLE SHOULD BE ALLOWED TO STAND AT -30°C FOR 240 HRS
5	HIGH TEMP / HUMIDITY TEST STORAGE	THE SAMPLE SHOULD BE ALLOWED TO STAND AT 60°C , 90% RH 240 HRS
6	THERMAL SHOCK (NOT OPERATED)	<p>THE SAMPLE SHOULD BE ALLOWED TO STAND THE FOLLOWING 10 CYCLES OF OPERATION :</p> <p>The diagram illustrates a thermal shock cycle. It starts at -30°C for 30 minutes. Then, it ramps up to +80°C in 3 minutes. It stays at +80°C for 30 minutes. Then, it ramps down to -30°C in 3 minutes. Finally, it stays at -30°C for 30 minutes. This entire sequence is labeled as '1 cycle'.</p>
7	ESD (ELECTROSTATIC DISCHARGE) (NOT OPERATED)	AIR DISCHARGE ± 12KV CONTACT DISCHARGE ± 8KV (ACCORDING TO IEC-61000-4-2)

NOTE (1) : THE TEST SAMPLES HAVE RECOVERY TIME FOR 2 HOURS AT ROOM TEMPERATURE BEFORE THE FUNCTION CHECK. IN THE STANDARD CONDITIONS , THERE IS NO DISPLAY FUNCTION NG ISSUE OCCURRED.

12.5 TESTING CONDITIONS AND INSPECTION CRITERIA

For the final test the testing sample must be stored at room temperature for 24 hours, after the tests listed in table 12.5 , standard specifications for reliability have been executed in order to ensure stability .

NO	ITEM	TEST MODEL	INSPECTION CRITERIA
1	Current consumption	Refer To Specification	The current consumption should conform to the product specification.
2	Contrast	Refer TO Specification	After the tests have been executed, the contrast must be larger than half of its initial value prior to the tests.
3	Appearance	Visual inspection	Defect free

12.6 OPERATION

- 12.6.1 Do not connect or disconnect modules to or from the main system while power is being supplied .
- 12.6.2 Use the module within specified temperature ; lower temperature causes the retardation of blinking speed of the display ; higher temperature makes overall display discolor . When the temperature returns to normality , the display will operate normally .
- 12.6.3 Adjust the LC driving voltage to obtain the optimum contrast .
- 12.6.4 Power On Sequence input signals should not be supplied to LCD module before power supply voltage is applied and reaches the specified value . If above sequence is not followed , CMOS LSIs of LCD modules may be damaged due to latch - up problem .
- 12.6.5 Not allowed to inflict any external stress and to cause any mechanical interference on the bending area of FPC during the tail bending backwards!
Do NOT stress FPC and IC on the Module!

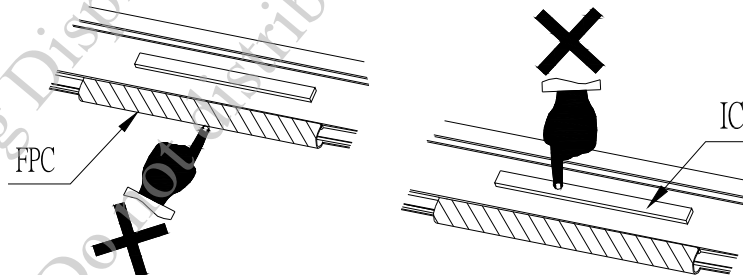

12.7 NOTICE

- 12.7.1 Use a grounded soldering iron when soldering connector I/O terminals . For soldering or repairing , take precaution against the temperature of the soldering iron and the soldering time to prevent peeling off the through-hole-pad .
- 12.7.2 Do not disassemble . EDT shall not be held responsible if the module is disassembled and upon the reassembly the module failed .
- 12.7.3 Do not charge static electricity , as the circuit of this module contains CMOS LSIs. A workman's body should always be static-protected by use of an ESD STRAP . Working clothes for such personnel should be of static-protected material .
- 12.7.4 Always ground the electrically-powered driver before using it to install the LCD module. While cleaning the work station by vacuum cleaner, do not bring the sucking mouth near the module ; static electricity of the electrically-powered driver or the vacuum cleaner may destroy the module .
- 12.7.5 Don't give external shock.
- 12.7.6 Don't apply excessive force on the surface.
- 12.7.7 Liquid in LCD is hazardous substance. Must not lick and swallow. When the liquid is attach to your, skin, cloth etc. Wash it out thoroughly and immediately.
- 12.7.8 Don't operate it above the absolute maximum rating.
- 12.7.9 Storage in a clean environment, free from dust, active gas, and solvent.
- 12.7.10 Store without any physical load.
- 12.7.11 Rewiring : no more than 3 times .