

EXAMINED BY : CC Chen	EMERGING DISPLAY TECHNOLOGIES CORPORATION	FILE NO . CAS-0008334
APPROVED BY:		ISSUE : MAY.25, 2018
Justin Horng		TOTAL PAGE : 24
		VERSION : 3

CUSTOMER ACCEPTANCE SPECIFICATIONS

MODEL NO. :

ET020011DMU

(GP)
FOR MESSRS :

CUSTOMER'S APPROVAL

DATE :

BY :

EMERGING DISPLAY
TECHNOLOGIES CORPORATION

MODEL NO.	VERSION	PAGE
ET020011DMU	3	0-1

RECORDS OF REVISION	DOC . FIRST ISSUE	AUG.19, 2016
---------------------	-------------------	--------------

DATE	REVISED PAGE NO.	SUMMARY
MAR.06, 2017	3	4. ELECTRICAL CHARACTERISTICS POWER SUPPLY CURRENT: TYP.=(3.5)→5;MAX.=(6)→7.5 MODIFY NOTE (4)
MAY.25, 2018	9	7. OUTLINE DIMENSIONS MARK Δ : ADDING FPC LENGTH DIMENSION & DETAIL FPC

CONFIDENTIAL
 Authorized for
 Emerging Display Technologies Corporation Only.
 Do not distribute without authorization.

TABLE OF CONTENTS

NO.	ITEM	PAGE
1.	GENERAL SPECIFICATIONS -----	1
2.	MECHANICAL SPECIFICATIONS -----	1
3.	ABSOLUTE MAXIMUM RATINGS -----	2
4.	ELECTRICAL CHARACTERISTICS -----	3
5.	TIMING CHARACTERISTICS -----	4 ~ 6
6.	OPTICAL CHARACTERISTICS -----	7, 8
7.	OUTLINE DIMENSIONS -----	9
8.	BLOCK DIMENSION -----	10
9.	DETAIL DRAWING OF DOT MATRIX -----	11
10.	INTERFACE SIGNALS -----	12, 13
11.	POWER SUPPLY -----	14
12.	INSPECTION CRITERION -----	15 ~ 24

CONFIDENTIAL
Authorized for
Emerging Display Technologies Corporation Only.
Do not distribute without authorization.

1. GENERAL SPECIFICATIONS

1.1 DATA SHEETS FOR CONTROLLER/DRIVER PLEASE REFER TO :

SITRONIX ST7775R

1.2 MATERIAL SAFETY DESCRIPTION

ASSEMBLIES SHALL COMPLY WITH EDT GREEN PRODUCT (GP) REQUIREMENTS, INCLUDING PROHIBITED MATERIALS/COMPONENTS CONTAINING LEAD, MERCURY, CADMIUM, HEXAVALENT CHROMIUM, POLYBROMINATED BIPHENYLS (PBB), POLYBROMINATED DIPHENYL ETHERS (PBDE), POLYCHLORINATED BIPHENYLS (PCB) CATEGORY, POLYCHLORINATED NAPHTHALENE (PCN) CATEGORY, POLYCHLORINATED TERPHENYLS (PCT) CATEGORY, CHLORINATED PARAFFINS (CP) CATEGORY, TRIBUTHYL TIN CATEGORY / TRIPHENYL TIN CATEGORY, ASBESTOS, SPECIFIC AZO COMPOUNDS, FORMALDEHYDE, POLYVINYL CHLORIDE (PVC) AND PVC BLENDS, OTHER BROMINATED ORGANIC COMPOUNDS AND OTHER CHLORINATED ORGANIC COMPOUNDS.

2. MECHANICAL SPECIFICATIONS

(1) DIAGONALS	-----	2.0 inch
(2) NUMBER OF DOTS	-----	176W * (RGB) * 220H DOTS
(3) MODULE SIZE	-----	38.18W * 53.32H * 2.9D(max) mm (WITHOUT FPC)
(4) ACTIVE AREA	-----	31.68W * 39.6H mm
(5) DOT SIZE	-----	0.06W * 0.18H mm
(6) PIXEL SIZE	-----	0.18W * 0.18H mm
(7) LCD TYPE	-----	TFT , TRANSMISSIVE
(8) COLOR	-----	262K
(9) VIEWING DIRECTION	-----	12 O'CLOCK (GRAY LEVEL INVERSION)
(10) BACK LIGHT	-----	LED , COLOR : WHITE
(11) INTERFACE MODE	-----	RGB 18 BIT, PARALLEL + SPI

3. ABSOLUTE MAXIMUM RATINGS

3.1 ELECTRICAL ABSOLUTE MAXIMUM RATINGS.

PARAMETER	SYMBOL	MIN.	MAX.	UNIT	REMARK
POWER SUPPLY VOLTAGE	IOVCC	-0.3	4.6	V	
	VCI	-0.3	4.6	V	
INPUT VOLTAGE	V _I	-0.3	IOVCC+0.5	V	
STATIC ELECTRICITY	—	—	—	V	NOTE (1)
LED BACKLIGHT DISSIPATION	PO	—	240	mW	
LED BACKLIGHT CURRENT	IF	—	60	mA	
LED BACKLIGHT REVERSE VOLTAGE	VR	—	5	V	

NOTE (1) : LCM SHOULD BE GROUNDED DURING HANDING LCM.

3.2 ENVIRONMENTAL ABSOLUTE MAXIMUM RATINGS.

ITEM	OPERATING		STORAGE		REMARK
	MIN.	MAX.	MIN.	MAX.	
AMBIENT TEMPERATURE	-20 °C	70 °C	-30 °C	80 °C	NOTE (1), (2)
HUMIDITY	NOTE (3)		NOTE (3)		WITHOUT CONDENSATION
VIBRATION	—	2.45 m/S ² (0.25 G)	—	11.76 m/S ² (1.2 G)	5~20Hz, 1HR 20~500Hz(20Hz), 1HR 20~500Hz(500Hz), 1HR X,Y,Z,TOTAL 3HR
SHOCK	—	29.4 m/S ² (3 G)	—	490 m/S ² (50 G)	10ms XYZ DIRECTIONS 1 TIME EACH
CORROSIVE GAS	NOT ACCEPTABLE		NOT ACCEPTABLE		

NOTE (1) : Ta AT -30°C : 48HR MAX.

80°C : 168HR MAX.

NOTE (2) : BACKGROUND COLOR CHANGES SLIGHTLY DEPENDING ON AMBIENT TEMPERATURE THIS PHENOMENON IS REVERSIBLE.

NOTE (3) : Ta ≤ 60°C : 90%RH MAX.(96 HRS MAX.)

Ta > 60°C : ABSOLUTE HUMIDITY MUST BE LOWER THAN THE HUMIDITY OF 90%RH AT 60°C.(96 HRS MAX.)

4. ELECTRICAL CHARACTERISTICS

Ta = 25 °C, VSS=0V

PARAMETER	SYMBOL	CONDITION	MIN.	TYP.	MAX.	UNIT	REMARK
POWER SUPPLY VOLTAGE	IOVCC	—	2.5	2.8	3.3	V	
	VCI		2.5	2.8	3.3	V	
INPUT VOLTAGE FOR LOGIC CIRCUITS	VI	“H” LEVEL	0.8IOVCC	—	IOVCC	V	
		“L” LEVEL	VSS	—	0.2IOVCC		
OUTPUT VOLTAGE FOR LOGIC CIRCUITS	VO	“H” LEVEL	0.8IOVCC	—	IOVCC	V	
		“L” LEVEL	VSS	—	0.2IOVCC		
POWER SUPPLY CURRENT	IC	—	—	5	7.5	mA	NOTE (1)
POWER SUPPLY FOR LED BACKLIGHT	VLED_A - VLED_K	IF =40 mA	—	3.3	4	V	NOTE (2)
LED LIFE TIME	—	ILED=20mA (PER.LED)	30K	—	—	hr	NOTE (3) NOTE (4)

NOTE (1) : $IC=I_{IOVCC}+I_{VCI}$

NOTE (2) : INTERNAL CIRCUIT DIAGRAM OF BACKLIGHT

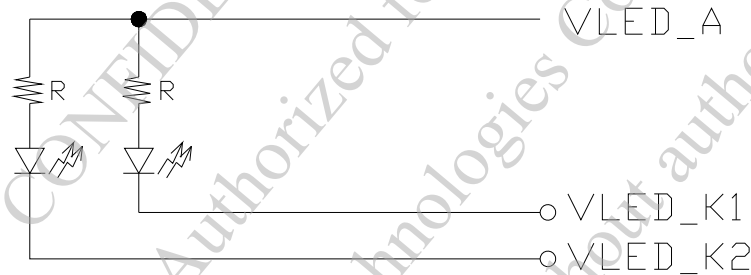

NOTE (3) : CONDITIONS, TA=25°C, CONTINUOUS LIGHTING.

NOTE (4) : DEFINITIONS OF FAILURE.

LCD LUMINANCE BECOMES HALF OF THE INITIAL VALUE.

NOTE (5) : AMBIENT TEMP. VS. ALLOWABLE FORWARD CURRENT. (PER LED)

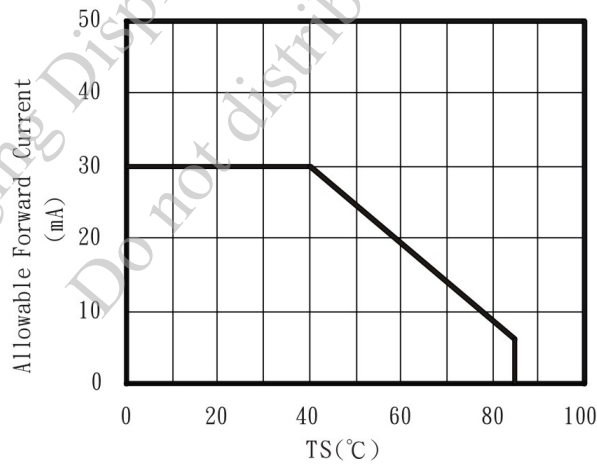

5. TIMING CHARACTERISTICS

5.1 SERIAL PERIPHERAL INTERFACE (SPI)TIMING CHARACTERISTICS

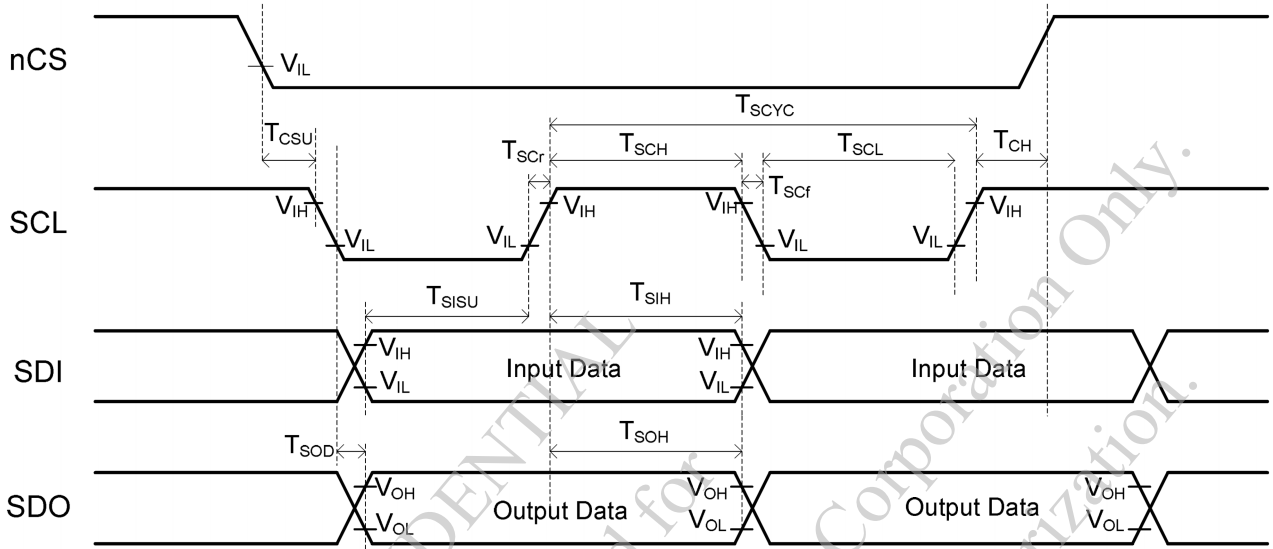

PARAMETER	SYMBOL	CONDITIONS	MIN.	MAX.	UNIT
CHIP SELECT SETUP TIME	TCSU	NCS	10	—	ns
CHIP SELECT HOLD TIME	TCH		50	—	ns
SERIAL CLOCK RISE/FALL TIME	TSCr, TSCf	SCL	—	5	ns
SCL "H" PULSE WIDTH (WRITE)	TSCH		40	—	ns
SCL "H" PULSE WIDTH (READ)	TSCH		100	—	ns
SERIAL CLOCK CYCLE (WRITE)	TSCYC		80	—	ns
SERIAL CLOCK CYCLE (READ)	TSCYC		200	—	ns
SCL "L" PULSE WIDTH (WRITE)	TSCL		40	—	ns
SCL "L" PULSE WIDTH (READ)	TSCL	100	—	ns	
SERIAL INPUT DATA SETUP TIME	TSISU	SDI	20	—	ns
SERIAL INPUT DATA HOLD TIME	TSIH		20	—	ns
SERIAL OUTPUT DATA SETUP TIME	TSOD	SDO	—	100	ns
SERIAL OUTPUT DATA HOLD TIME	TSOH		5	—	ns

5.2 RGB INTERFACE TIMING CHARACTERISTICS

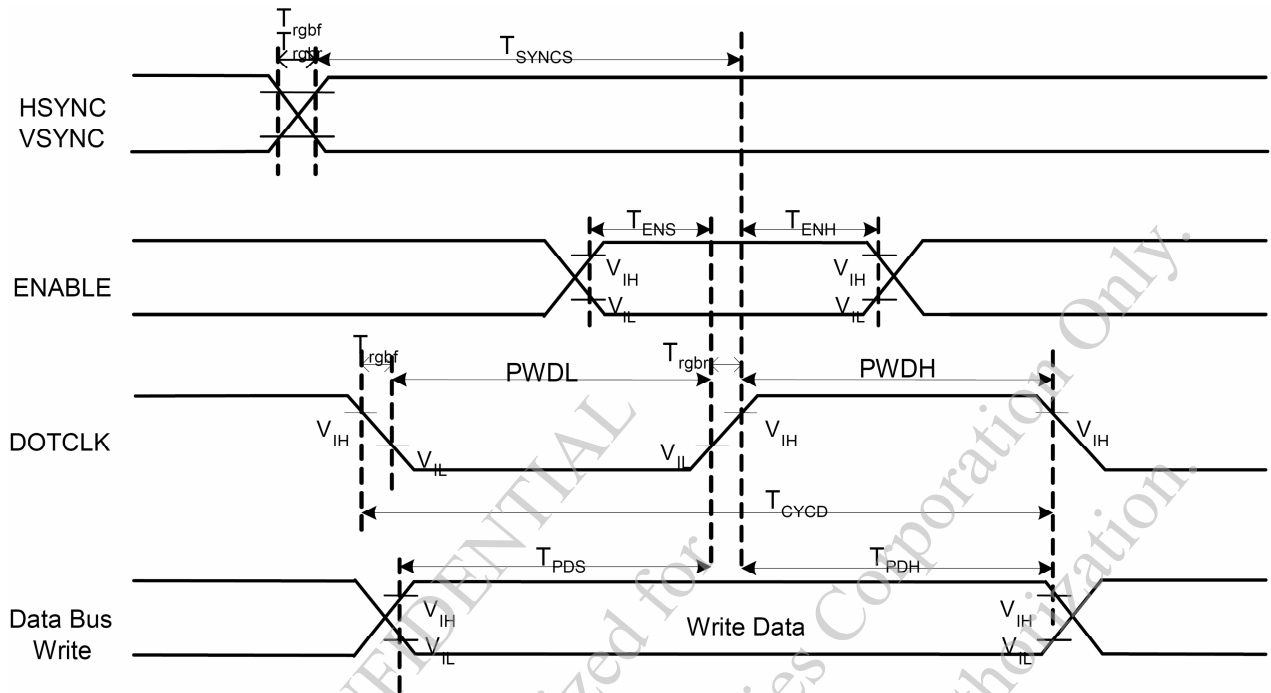

PARAMETER	SYMBOL	CONDITIONS	MIN.	MAX.	UNIT
VSYNC, HSYNC SETUP TIME	T_{SYNCS}	HSYNC, VSYNC	0	—	ns
VSYNC, HSYNC RISE/FALL TIME	T_{rghr}, T_{rghf}		—	25	ns
ENABLE SETUP TIME	T_{ENS}	ENABLE	10	—	ns
ENABLE HOLD TIME	T_{ENH}		10	—	ns
DOTCLK HIGH-LEVEL PULSE WIDTH	$PWDH$	DOTCLK	40	—	ns
DOTCLK LOW-LEVEL PULSE WIDTH	$PWDL$		40	—	ns
DOTCLK CYCLE TIME	T_{CYCD}		100	—	ns
DOTCLK RISE/FALL TIME	T_{rghr}, T_{rghf}		—	25	ns
PD DATA SETUP TIME	T_{PDS}	DB	10	—	ns
PD DATA HOLD TIME	T_{PDH}		40	—	ns

TIMING CHART OF SIGNALS IN 18 BIT RGB INTERFACE MODE

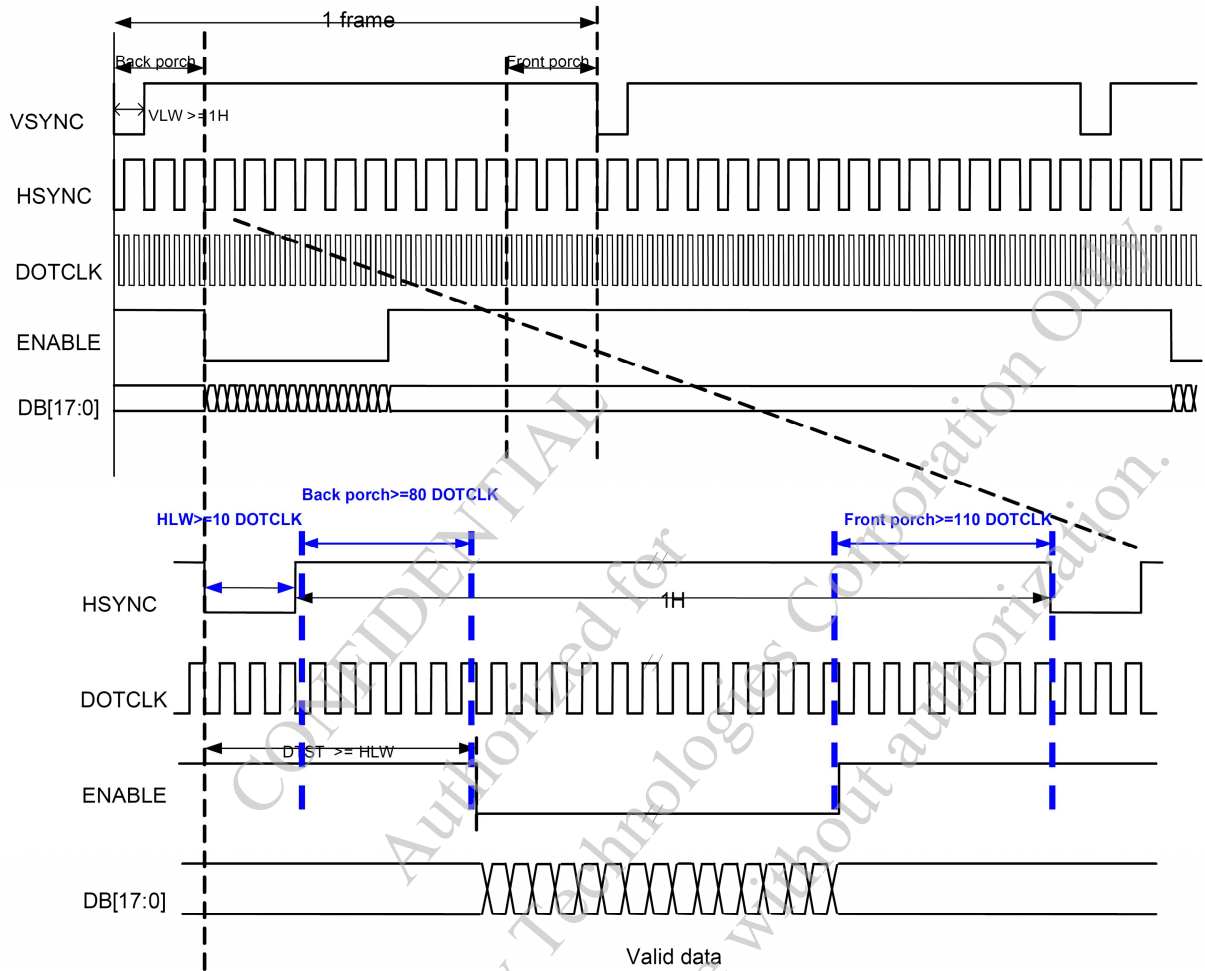

VLW : VSYNC LOW PERIOD
HLW : HSYNC LOW PERIOD
DTST : DATA TRANSFER STARTUP TIME

CONFIDENTIAL
Authorized for Emerging Display Technologies Corporation Only.
Do not distribute without authorization.

6. OPTICAL CHARACTERISTICS (NOTE 1)

6.1 OPTICAL CHARACTERISTICS

Ta=25 °C

ITEM	SYMBOL	CONDITION	MIN.	TYP.	MAX.	UNIT	REMARK	
VIEWING ANGLE	θ_{y+}	CR \geq 10	$\theta_x = 0^\circ$	55	60	—	deg.	NOTE (2) NOTE (3)
	θ_{y-}			63	70	—		
	θ_{x-}		$\theta_y = 0^\circ$	63	70	—		
	θ_{x+}			63	70	—		
CONTRAST RATIO	CR	$\theta_x = \theta_y = 0^\circ$	300	350	—		NOTE (3)	
RESPONSE TIME	T _r + T _f	$\theta_x = \theta_y = 0^\circ$	—	35	50	msec	NOTE (4)	
THE BRIGHTNESS OF MODULE	B	$\theta_x = \theta_y = 0^\circ$ IF = 40mA	230	280	—	cd/m ²	NOTE (5)	
COLOR OF CIE COORDINATE	WHITE	W _x	$\theta_x = 0^\circ, \theta_y = 0^\circ$ IF = 40mA NTSC : 55%	0.26	0.31	0.36	—	NOTE (6)
		W _y		0.28	0.33	0.38		
	RED	R _x		0.565	0.615	0.665		
		R _y		0.28	0.34	0.39		
	GREEN	G _x		0.28	0.33	0.38		
		G _y		0.55	0.60	0.65		
	BLUE	B _x		0.11	0.145	0.185		
		B _y		0.04	0.06	0.11		
THE BRIGHTNESS OF UNIFORMITY	—	IF = 40mA	70	75	—	%	—	

NOTE (1) : TEST EQUIPMENT SETUP :

AFTER STABILIZING AND LEAVING THE PANEL ALONE AT A GIVEN TEMPERATURE FOR 30 MINUTES. MEASUREMENT SHOULD BE EXECUTED IN A STABLE, WINDLESS, AND DARK ROOM. OPTICAL SPECIFICATIONS ARE MEASURED BY TOPCON BM-7 (FAST) WITH A VIEWING ANGLE OF 1° AT A DISTANCE OF 50cm AND NORMAL DIRECTION.

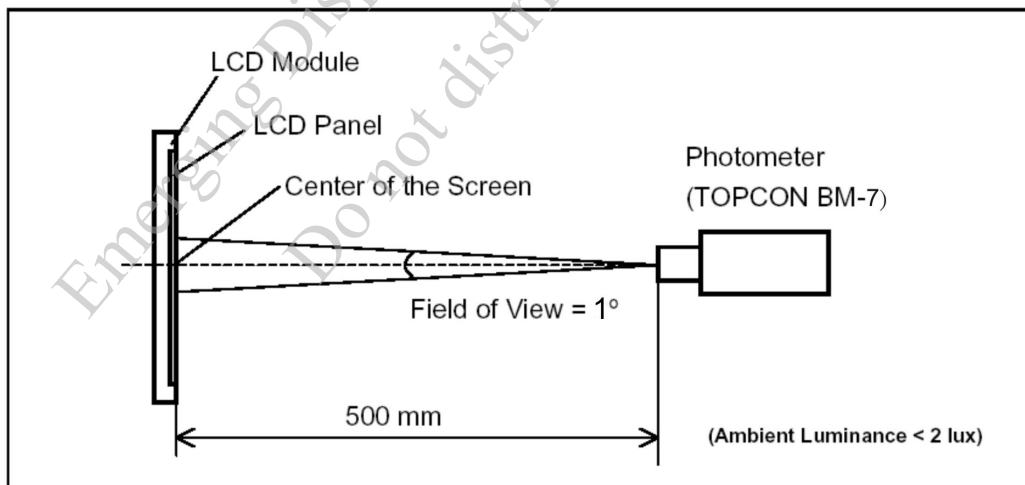

NOTE (2) : DEFINITION OF VIEWING ANGLE :

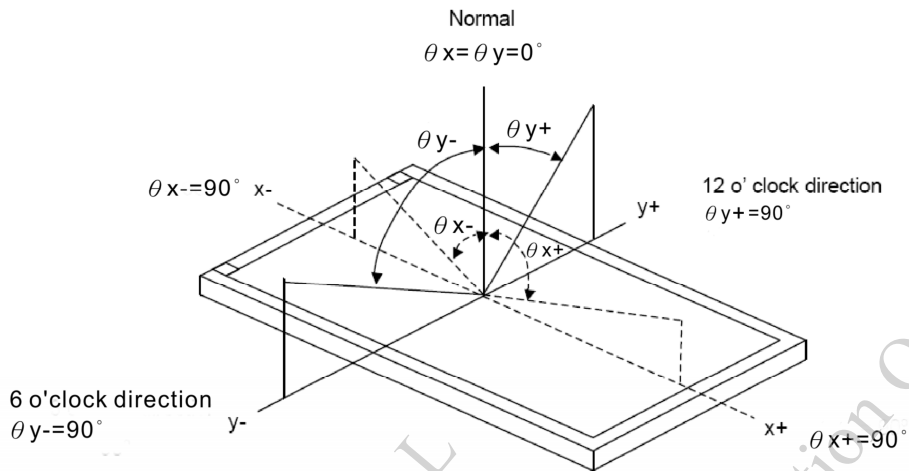

NOTE (3) : DEFINITION OF CONTRAST RATIO :

$$\text{CONTRAST RATIO (CR)} = \frac{\text{BRIGHTNESS MEASURED WHEN LCD IS AT "WHITE STATE"}}{\text{BRIGHTNESS MEASURED WHEN LCD IS AT "BLACK STATE"}}$$

NOTE (4) : DEFINITION OF RESPONSE TIME : TR AND TF

THE FIGURE BELOW IS THE OUTPUT SIGNAL OF THE PHOTO DETECTOR.

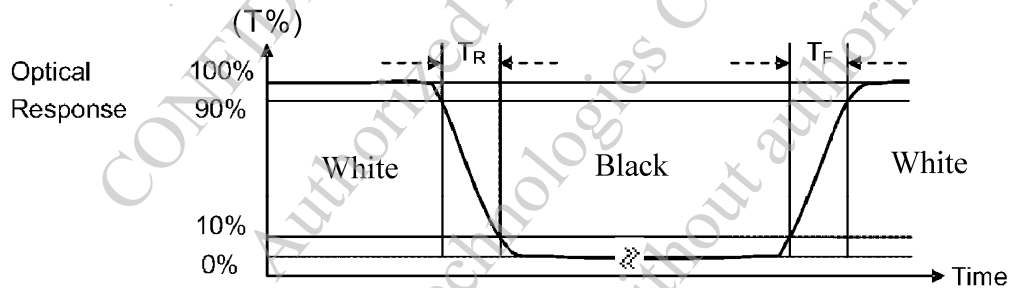

NOTE (5) : BRIGHTNESS MEASURED WHEN LCD IS AT " WHITE STATE"

NOTE (6) : THE 100% TRANSMISSION IS DEFINED AS THE TRANSMISSION OF LCD PANEL WHEN ALL THE INPUT TERMINALS OF MODULE ARE ELECTRICALLY OPENED.

6.2 THE TEST METHOD OF BRIGHTNESS AND UNIFORMITY

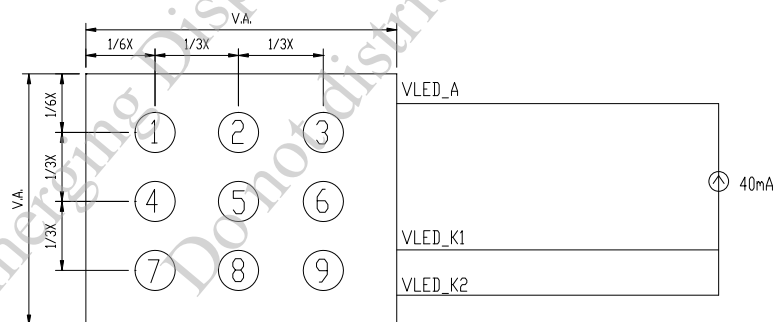

UNIT : mm

6.3 THE CALCULATING METHOD OF UNIFORMITY

$$\text{UNIFORMITY} = \left[1 - \frac{\text{MAXIMUM BRIGHTNESS} - \text{MINIMUM BRIGHTNESS}}{\text{AVERAGE BRIGHTNESS}} \right] \times 100\%$$

MODEL NO. ET020011DMU	VERSION 3	PAGE 9
--------------------------	--------------	-----------

7. OUTLINE DIMENSIONS

VIEWING DIRECTION

Best Contrast but with Gray Level Inversion

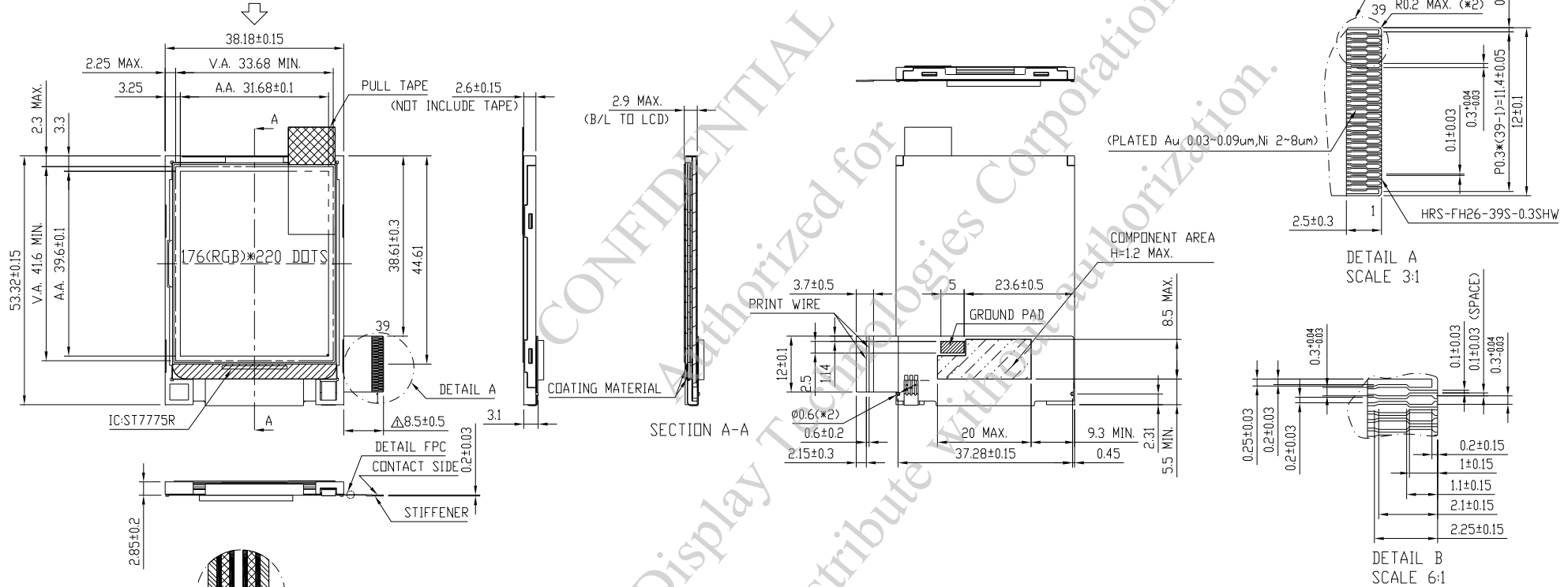

- △DETAIL FPC
- BASE FILM (1/2 mil)
- ADHESIVE
- ▨ COPPER (1/2 oz)(18 um)
- ▩ COVER LAYER (1/2 mil)

UNIT : mm
SCALE : NTS
NOT SPECIFIED TOLERANCE IS ± 0.3
NOTE :
1.RECOMMEND MATCH CONNECTOR :HRS-FH26-39S-0.3SHW
2.MARK△MODIFY (NUMBER NOTE MODIFY VERSION)

8. BLOCK DIMENSION

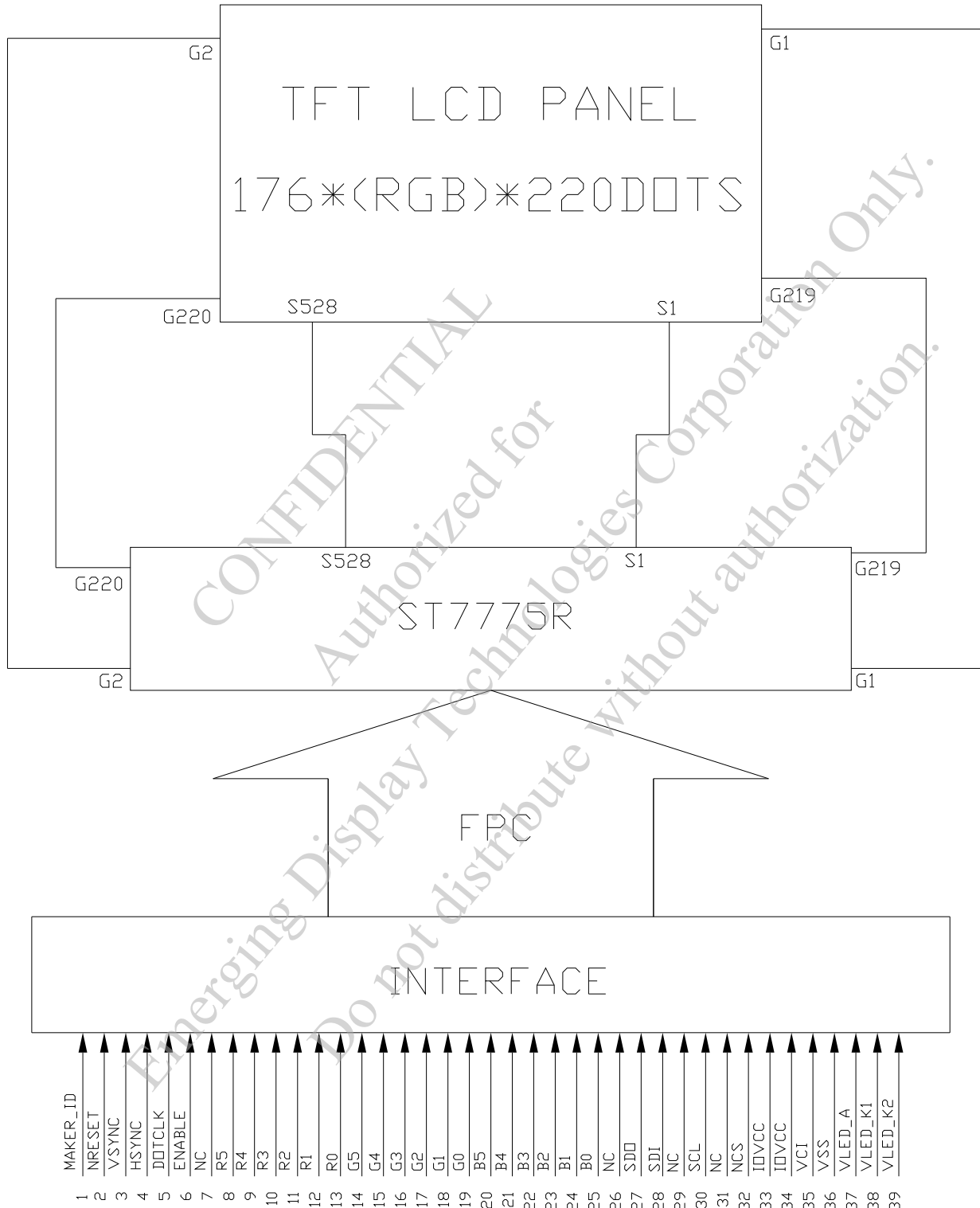

9. DETAIL DRAWING OF DOT MATRIX

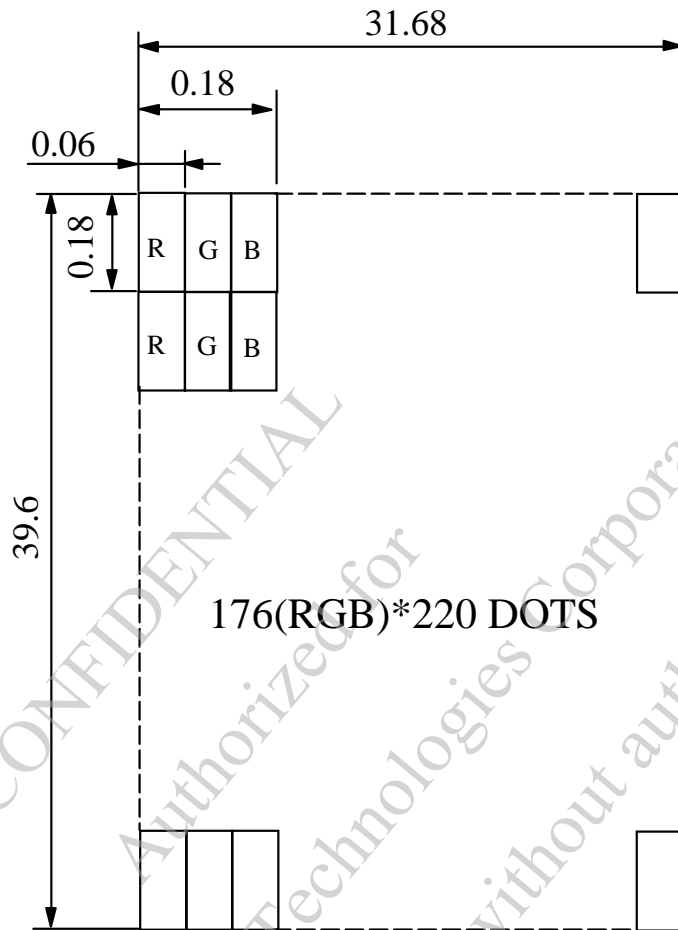

UNIT : mm
SCALE : NTS
NOT SPECIFIED TOLERANCE IS ± 0.1
DOTS MATRIX TOLERANCE IS ± 0.01

CONFIDENTIAL
Authorized for Emerging Display Technologies Corporation Only.
Do not distribute without authorization.

10. INTERFACE SIGNALS

PIN NO.	SYMBOL	FUNCTION
1	MAKER_ID	MAKER'S IDENTIFICATION (MAY ESTABLISH "H", "L" OR "NC") IF THE CUSTOMER HAS MORE THAN TWO MAKERS WHO APPLIED DIFFERENT S/W, CAN USE THIS PIN TO DETECT THE CODE BY THE MPU AND DECIDE THE MAKER'S ID. MOST IMPORTANTLY, THE CUSTOMER MUST DESIGN THIS PIN ON THE MAIN BOARD AS WELL AND LEAVE IT OPEN AS NOT USED. NOTE : EDT MODULE'S SETTING IS "H".
2	NRESET	RESET
3	VSYNC	VERTICAL SYNCHRONIZING SIGNAL IN RGB INTERFACE. HAS TO BE FIXED TO IOVCC LEVEL IF IT IS NOT USED.
4	HSYNC	HORIZONTAL SYNCHRONIZING SIGNAL. HAS TO BE FIXED TO IOVCC LEVEL IF IT IS NOT USED.
5	DOTCLK	PIXEL CLOCK SIGNAL IN RGB INTERFACE. HAS TO BE FIXED TO VSS LEVEL IF IT IS NOT USED.
6	ENABLE	DATA ENABLE SIGNAL IN RGB INTERFACE. HAS TO BE FIXED TO VSS LEVEL IF IT IS NOT USED.
7	NC	NOT CONNECTED
8	R5	<p>INPUT DATA BUS IF NOT USED, PLEASE FIX THIS PIN AT GND LEVEL.</p>
9	R4	
10	R3	
11	R2	
12	R1	
13	R0	
14	G5	
15	G4	
16	G3	
17	G2	
18	G1	
19	G0	
20	B5	
21	B4	
22	B3	
23	B2	
24	B1	
25	B0	
26	NC	NOT CONNECTED
27	SDO	SERIAL DATA OUTPUT PIN IN SERIAL BUS SYSTEM INTERFACE. THE DATA IS OUTPUTTED ON THE FALLING EDGE OF SCL SIGNAL. IF NOT USED, PLEASE LET THIS PIN FLOATING.
28	SDI	SERIAL DATA INPUT PIN IN SERIAL BUS SYSTEM INTERFACE. THE DATA IS INPUTTED ON THE RISING EDGE OF THE SCL SIGNAL. IF NOT USED, PLEASE FIX THIS PIN AT GND LEVEL.
29	NC	NOT CONNECTED

PIN NO.	SYMBOL	FUNCTION
30	SCL	(SCL) SERVER AS SERIAL DATA CLOCK IN SERIAL BUS SYSTEM INTERFACE. IF NOT USED, PLEASE FIX THIS PIN AT IOVCC OR GND LEVEL.
31	NC	NOT CONNECTED
32	NCS	CHIP SELECT INPUT PIN. LOW : CHIP CAN BE ACCESSED; HIGH : CHIP CANNOT BE ACCESSED.
33	IOVCC	POWER SUPPLY FOR INTERFACE SIGNAL
34	IOVCC	POWER SUPPLY FOR INTERFACE SIGNAL
35	VCI	POWER SUPPLY FOR ANALOG
36	VSS	GROUND
37	VLED_A	LED BACKLIGHT POWER (A)
38	VLED_K1	LED BACKLIGHT POWER (K1)
39	VLED_K2	LED BACKLIGHT POWER (K2)

CONFIDENTIAL
Authorized for
Emerging Display Technologies Corporation Only.
Do not distribute without authorization.

11. POWER SUPPLY

11.1 POWER SUPPLY FOR LCM

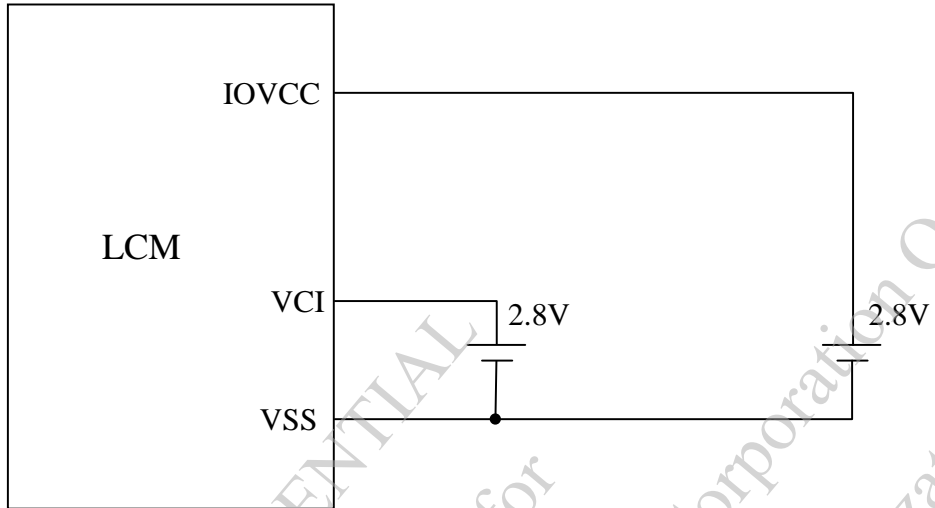

11.2 POWER SUPPLY FOR LCM BACKLIGHT

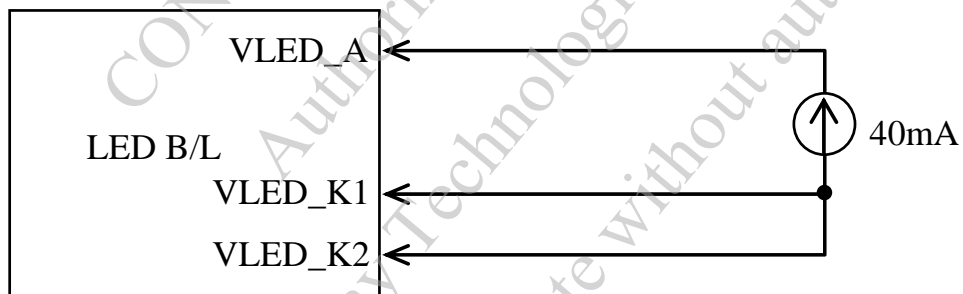

12. INSPECTION CRITERION

12.1 APPLICATION

THIS INSPECTION STANDARD IS TO BE APPLIED TO THE LCD MODULE DELIVERED FROM EMERGING DISPLAY TECHNOLOGIES CORP.(E.D.T) TO CUSTOMERS

12.2 INSPECTION CONDITIONS

12.2.1 (1)OBSERVATION DISTANCE : 35±5cm

(2)VIEW ANGLE :

NON-OPERATION CONDITION : ±5°

(PERPENDICULAR TO LCD PANEL SURFACE)

OPERATION CONDITION : ±45°

(PERPENDICULAR TO LCD PANEL SURFACE)

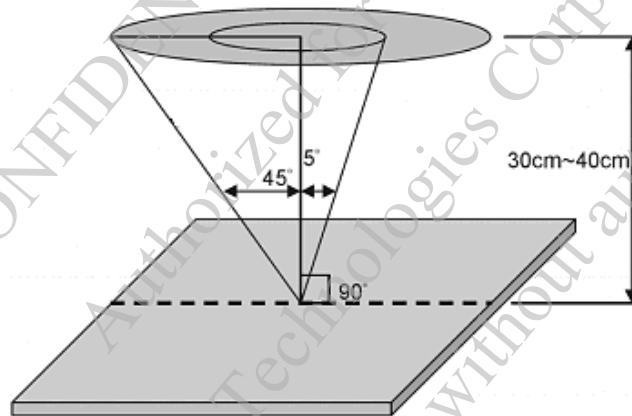

12.2.2 ENVIRONMENT CONDITIONS :

AMBIENT TEMPERATURE		20°C~25°C
AMBIENT HUMIDITY		65±20%RH
AMBIENT ILLUMINATION	COSMETIC INSPECTION	MORE THAN 600Lux
	FUNCTIONAL INSPECTION	300~500 Lux

12.2.3 INSPECTION LOT

QUANTITY PER DELIVERY LOT FOR EACH MODEL

12.2.4 INSPECTION METHOD

A SAMPLING INSPECTION SHALL BE MADE ACCORDING TO THE FOLLOWING PROVISIONS TO JUDGE THE ACCEPTABILITY

(a)APPLICABLE STANDARD :

MIL-STD-105E

NORMAL INSPECTION, SINGLE SAMPLING

LEVEL II

(b)AQL : MAJOR DEFECT : AQL 0.65

MINOR DEFECT : AQL 1.0

12.3 INSPECTION STANDARDS

12.3.1 VISUAL DEFECTS CLASSIFICATION

TYPE OF DEFECT	INSPECTION ITEM	DEFECT FEATURE	AQL
MAJOR DEFECT	1.DISPLAY ON	<ul style="list-style-type: none"> • DEFECT TO MISS SPECIFIED DISPLAY FUNCTION, FOR ALL AND SPECIFIED DOTS EX: DISCONNECTION , SHORT CIRCUIT ETC 	0.65
	2.BACKLIGHT	<ul style="list-style-type: none"> • NO LIGHT • FLICKERING AND OTHER ABNORMAL ILLUMINATION 	
	3.DIMENSIONS	<ul style="list-style-type: none"> • SUBJECT TO INDIVIDUAL ACCEPTANCE SPECIFICATIONS 	
MINOR DEFECT	1.DISPLAY ZONE	<ul style="list-style-type: none"> • BLACK/WHITE SPOT • BUBBLES ON POLARIZER • BLACK/WHITE LINE • SCRATCH • CONTAMINATION • LEVER COLOR SPREAD 	1.0
	2.BEZEL ZONE	<ul style="list-style-type: none"> • STAINS • SCRATCHES • FOREIGN MATTER 	
	3.SOLDERING	<ul style="list-style-type: none"> • INSUFFICIENT SOLDER • SOLDERED IN INCORRECT POSITION • CONVEX SOLDERING SPOT • SOLDER BALLS • SOLDER SCRAPS 	
	4.DISPLAY ON (ALL ON)	<ul style="list-style-type: none"> • LIGHT LINE 	

12.3.2 MODULE DEFECTS CLASSIFICATION

NO.	ITEM	CRITERIA												
1	DISPLAY ON INSPECTION	(1)INCORRECT PATTERN (2)MISSING SEGMENT (3)DIM SEGMENT (4)OPERATING VOLTAGE BEYOND SPEC												
2	OVERALL DIMENSIONS	(1)OVERALL DIMENSION BEYOND SPEC												
3	DOT DEFECT	(1)INSPECTION PATTERN: FULL WHITE, FULL BLACK, RED, GREEN AND BLUE SCREENS. (2) <table border="1" style="margin-left: 20px;"> <thead> <tr> <th>ITEMS</th> <th>ACCEPTABLE COUNT</th> </tr> </thead> <tbody> <tr> <td>BRIGHT DOT</td> <td>$N \leq 1$</td> </tr> <tr> <td>DARK DOT</td> <td>$N \leq 3$</td> </tr> <tr> <td>TOTAL BRIGHT AND DARK DOTS</td> <td>$N \leq 3$</td> </tr> </tbody> </table> <p>NOTE :</p> <p>1. THE DEFINITION OF DOT : THE SIZE OF A DEFECTIVE DOT OVER 1/2 OF WHOLE DOT IS REGARDED AS ONE DEFECTIVE DOT.</p> <p>2. BRIGHT DOT : DOTS APPEAR BRIGHT AND UNCHANGED IN SIZE IN WHICH LCD PANEL IS DISPLAYING UNDER BLACK PATTERN.</p> <p>3. DARK DOT : DOTS APPEAR DARK AND UNCHANGED IN SIZE IN WHICH LCD PANEL IS DISPLAYING UNDER PURE RED, GREEN, BLUE PICTURE.</p>	ITEMS	ACCEPTABLE COUNT	BRIGHT DOT	$N \leq 1$	DARK DOT	$N \leq 3$	TOTAL BRIGHT AND DARK DOTS	$N \leq 3$				
ITEMS	ACCEPTABLE COUNT													
BRIGHT DOT	$N \leq 1$													
DARK DOT	$N \leq 3$													
TOTAL BRIGHT AND DARK DOTS	$N \leq 3$													
4	FOREIGN BLACK/WHITE/ BRIGHT LINE/ SCRATCH OF VIEWING AREA	<table border="1" style="margin-left: 20px;"> <thead> <tr> <th>LENGTH : L</th> <th>WIDTH : W</th> <th>PERMISSIBLE NO.</th> </tr> </thead> <tbody> <tr> <td>$L \leq 0.3$</td> <td>$W \leq 0.05$</td> <td>IGNORE</td> </tr> <tr> <td>$0.3 < L \leq 2$</td> <td>$0.05 < W \leq 0.1$</td> <td>3</td> </tr> <tr> <td>$2 < L$</td> <td>$0.1 < W$</td> <td>NONE</td> </tr> </tbody> </table> <p>WIDTH : W mm, LENGTH : L mm</p>	LENGTH : L	WIDTH : W	PERMISSIBLE NO.	$L \leq 0.3$	$W \leq 0.05$	IGNORE	$0.3 < L \leq 2$	$0.05 < W \leq 0.1$	3	$2 < L$	$0.1 < W$	NONE
LENGTH : L	WIDTH : W	PERMISSIBLE NO.												
$L \leq 0.3$	$W \leq 0.05$	IGNORE												
$0.3 < L \leq 2$	$0.05 < W \leq 0.1$	3												
$2 < L$	$0.1 < W$	NONE												
5	FOREIGN MATTER \ BLACK SPOTS \ WHITE SPOTS \ DENT (INCLUDING LIGHT LEAKAGE DUE TO POLARIZING PLATES PINHOLES, ETC.)	<table border="1" style="margin-left: 20px;"> <thead> <tr> <th>AVERAGE DIAMETER (mm): D</th> <th>NUMBER OF PIECES PERMITTED</th> </tr> </thead> <tbody> <tr> <td>$D \leq 0.1$</td> <td>IGNORE</td> </tr> <tr> <td>$0.1 < D \leq 0.3$</td> <td>3</td> </tr> <tr> <td>$0.3 < D$</td> <td>NONE</td> </tr> </tbody> </table> <p>NOTE : DIAMETER $D=(a+b)/2$</p> 	AVERAGE DIAMETER (mm): D	NUMBER OF PIECES PERMITTED	$D \leq 0.1$	IGNORE	$0.1 < D \leq 0.3$	3	$0.3 < D$	NONE				
AVERAGE DIAMETER (mm): D	NUMBER OF PIECES PERMITTED													
$D \leq 0.1$	IGNORE													
$0.1 < D \leq 0.3$	3													
$0.3 < D$	NONE													

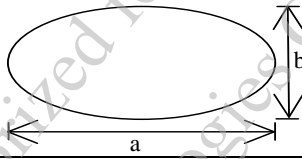
NO.	ITEM	CRITERIA		
			AVERAGE DIAMETER (mm) : D	NUMBER OF PIECES PERMITTED
6	BUBBLES OF POLARIZER /DIRT/CF FAIL /SURFACE STAINS	BUBBLE ON THE POLARIZER	$D \leq 0.25$	IGNORE
			$0.25 < D \leq 0.5$	$N \leq 5$
			$0.5 < D$	NONE
		SURFACE STAINS	$D < 0.1 \text{ mm}$	IGNORE
			$0.1 < D \leq 0.3 \text{ mm}$	$N \leq 3$
		CF FAIL / SPOT	$D < 0.1 \text{ mm}$	IGNORE
$0.1 < D \leq 0.3 \text{ mm}$	$N \leq 3$			
		<p>NOTE : (1)POLARIZER BUBBLE IS DEFINED AS THE BUBBLE APPEARS ON ACTIVE DISPLAY AREA. THE DEFECT OF POLARIZER BUBBLE SHALL BE IGNORED IF THE POLARIZER BUBBLE APPEARS ON THE OUTSIDE OF ACTIVE DISPLAY AREA.</p> <p>(2)THE EXTRANEIOUS SUBSTANCE IS DEFINED AS IT CAN BE OBSERVED WHEN THE MODULE IS POWER ON.</p> <p>(3)THE DEFINITION OF AVERAGE DIAMETER, D IS DEFINED AS FOLLOWING.</p> <p>AVERAGE DIAMETER (D)=(a+b)/2</p> 		
7	LINE DEFECT ON DISPLAY	OBVIOUS VERTICAL OR HORIZONTAL LINE DEFECT IS NOT ALLOWED		
8	MURA ON DISPLAY	IT'S OK IF MURA IS SLIGHT VISIBLE THROUGH 6% ND FILTER		
9	UNEVEN COLOR SPREAD, COLORATION	(1)TO BE DETERMINED BASED UPON THE STANDARD SAMPLE.		
10	BEZEL APPEARANCE	(1)BEZEL MAY NOT HAVE RUST, BE DEFORMED OR HAVE FINGER PRINTS STAINS OF OTHER CONTAMINATION. (2)BEZEL MUST COMPLY WITH JOB SPECIFICATIONS.		
11	PCB	<p>(1)THERE MAY NOT BE MORE THAN 2mm OF SEALANT OUTSIDE THE SEAL AREA ON THE PCB, AND THERE SHOULD BE NO MORE THAN THREE PLACES.</p> <p>(2)NO OXIDATION OR CONTAMINATION PCB TERMINALS.</p> <p>(3)PARTS ON PCB MUST BE THE SAME AS ON THE PRODUCTION CHARACTERISTIC CHART. THERE SHOULD BE NO WRONG PARTS, MISSING PARTS OR EXCESS PARTS.</p> <p>(4)THE JUMPER ON THE PCB SHOULD CONFORM TO THE PRODUCT CHARACTERISTIC CHART.</p> <p>(5)IF SOLDER GETS ON BEZEL TAB PADS, LED PAD, ZEBRA PAD OR SCREW HOLD PAD; MAKE SURE IT IS SMOOTHED DOWN.</p>		

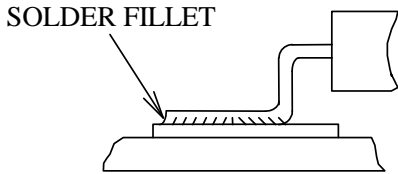
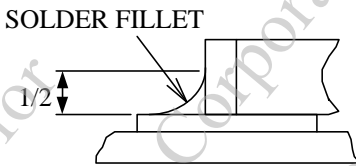
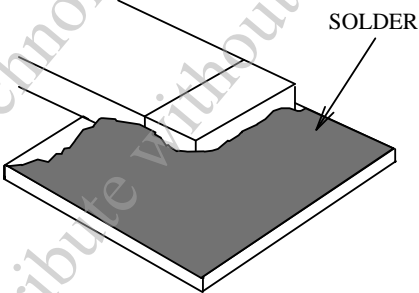
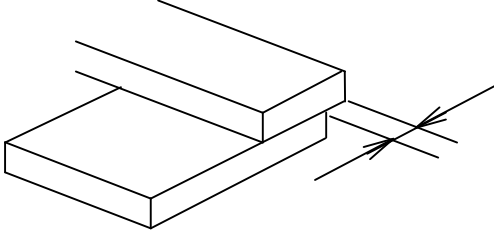
NO.	ITEM	CRITERIA
12	SOLDERING	<p>(1)NO SOLDERING FOUND ON THE SPECIFIED PLACE (2)INSUFFICIENT SOLDER</p> <p>(a)LSI, IC A POOR WETTING OF SOLDER IS BETWEEN LOWER BEND OR "HEEL" OF LEAD AND PAD</p>  <p>(b)CHIP COMPONENT · SOLDER IS LESS THAN 50% OF SIDES AND FRONT FACE WETTING</p>  <p>· SOLDER WETS 3 SIDES OF TERMINAL, BUT LESS THAN 25% OF SIDES AND FRONT SURFACE AREA ARE COVERED</p>  <p>(3)PARTS ALIGNMENT (a)LSI, IC LEAD WIDTH IS MORE THAN 50% BEYOND PAD OUTLINE</p> 

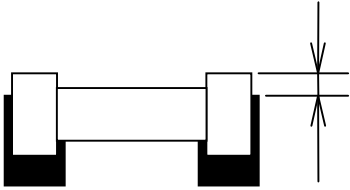
NO.	ITEM	CRITERIA
12	SOLDERING	<p>(b)CHIP COMPONENT COMPONENT IS OFF CENTER, AND MORE THAN 50% OF THE LEADS IS OFF THE PAD OUTLINE</p>  <p>(4)NO UNMELTED SOLDER PASTE MAY BE PRESENT ON THE PCB. (5)NO COLD SOLDER JOINTS, MISSING SOLDER CONNECTIONS, OXIDATION OR ICICLE. (6)NO RESIDUE OR SOLDER BALLS ON PCB. (7)NO SHORT CIRCUITS IN COMPONENTS ON PCB.</p>
13	BACKLIGHT	<p>(1)NO LIGHT (2)FLICKERING AND OTHER ABNORMAL ILLUMINATION (3)SPOTS OR SCRATCHES THAT APPEAR WHEN LIT MUST BE JUDGED USING LCD SPOT, LINES AND CONTAMINATION STANDARDS. (4)BACKLIGHT DOESN'T LIGHT OR COLOR IS WRONG.</p>
14	GENERAL APPEARANCE	<p>(1)NO OXIDATION, CONTAMINATION, CURVES OR, BENDS ON INTERFACE PIN (OLB) OF TCP. (2)NO CRACKS ON INTERFACE PIN (OLB) OF TCP. (3)NO CONTAMINATION, SOLDER RESIDUE OR SOLDER BALLS ON PRODUCT. (4)THE IC ON THE TCP MAY NOT BE DAMAGED, CIRCUITS. (5)THE UPPERMOST EDGE OF THE PROTECTIVE STRIP ON THE INTERFACE PIN MUST BE PRESENT OR LOOK AS IF IT CAUSE THE INTERFACE PIN TO SEVER. (6)THE RESIDUAL ROSIN OR TIN OIL OF SOLDERING (COMPONENT OR CHIP COMPONENT) IS NOT BURNED INTO BROWN OR BLACK COLOR. (7)SEALANT ON TOP OF THE ITO CIRCUIT HAS NOT HARDENED. (8)PIN TYPE MUST MATCH TYPE IN SPECIFICATION SHEET. (9)LCD PIN LOOSE OR MISSING PINS. (10)PRODUCT PACKAGING MUST THE SAME AS SPECIFIED ON PACKAGING SPECIFICATION SHEET. (11)PRODUCT DIMENSION AND STRUCTURE MUST CONFORM TO PRODUCT SPECIFICATION SHEET. (12)THE APPEARANCE OF HEAT SEAL SHOULD NOT ADMIT ANY DIRT AND BREAK.</p>

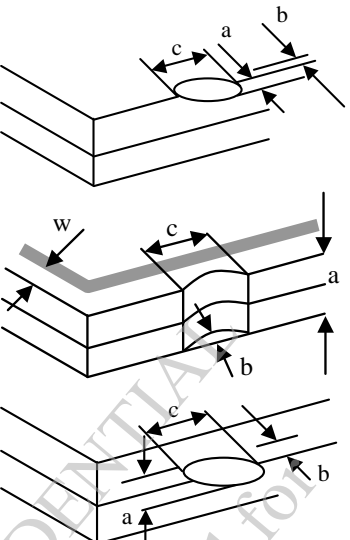
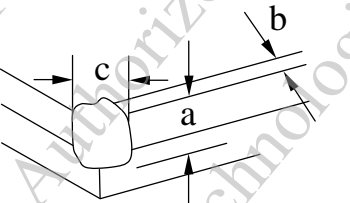
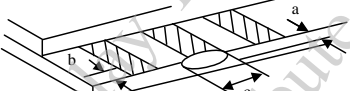
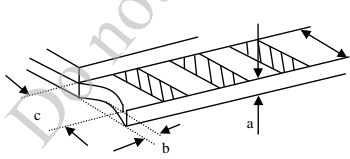
NO.	ITEM	CRITERIA									
15	CRACKED GLASS	<p>THE LCD WITH EXTENSIVE CRACK IS NOT ACCEPTABLE</p> <p>GENERAL GLASS CHIP :</p>  <table border="1" data-bbox="933 414 1455 504"> <thead> <tr> <th>a</th> <th>b</th> <th>c</th> </tr> </thead> <tbody> <tr> <td>$\leq t/2$</td> <td>< VIEWING AREA</td> <td>$\leq 1/8X$</td> </tr> <tr> <td>$t/2 > , \leq 2t$</td> <td>$\leq W/2$</td> <td>$\leq 1/8X$</td> </tr> </tbody> </table> <p>*W=DISTANCE BETWEEN SEALANT AREA AND LCD PANEL EDGE X = LCD SIDE LENGTH t = GLASS THICKNESS</p>	a	b	c	$\leq t/2$	< VIEWING AREA	$\leq 1/8X$	$t/2 > , \leq 2t$	$\leq W/2$	$\leq 1/8X$
		a	b	c							
		$\leq t/2$	< VIEWING AREA	$\leq 1/8X$							
		$t/2 > , \leq 2t$	$\leq W/2$	$\leq 1/8X$							
<p>CORNER PART :</p>  <table border="1" data-bbox="933 1003 1455 1086"> <thead> <tr> <th>a</th> <th>b</th> <th>c</th> </tr> </thead> <tbody> <tr> <td>$\leq t/2$</td> <td>< VIEWING AREA</td> <td>$\leq 1/8X$</td> </tr> <tr> <td>$> t/2 , \leq 2t$</td> <td>$\leq W/2$</td> <td>$\leq 1/8X$</td> </tr> </tbody> </table> <p>*W=DISTANCE BETWEEN SEALANT AREA AND LCD PANEL EDGE X = LCD SIDE LENGTH t = GLASS THICKNESS</p>	a	b	c	$\leq t/2$	< VIEWING AREA	$\leq 1/8X$	$> t/2 , \leq 2t$	$\leq W/2$	$\leq 1/8X$		
a	b	c									
$\leq t/2$	< VIEWING AREA	$\leq 1/8X$									
$> t/2 , \leq 2t$	$\leq W/2$	$\leq 1/8X$									
<p>CHIP ON ELECTRODE PAD</p>  <table border="1" data-bbox="933 1276 1455 1332"> <thead> <tr> <th>a</th> <th>b</th> <th>c</th> </tr> </thead> <tbody> <tr> <td>$\leq t$</td> <td>$\leq 0.5\text{mm}$</td> <td>$\leq 1/8X$</td> </tr> </tbody> </table> <p>* X=LCD SIDE WIDTH t=GLASS THICKNESS</p>	a	b	c	$\leq t$	$\leq 0.5\text{mm}$	$\leq 1/8X$					
a	b	c									
$\leq t$	$\leq 0.5\text{mm}$	$\leq 1/8X$									
 <table border="1" data-bbox="933 1433 1455 1489"> <thead> <tr> <th>a</th> <th>b</th> <th>c</th> </tr> </thead> <tbody> <tr> <td>$\leq t$</td> <td>$\leq 1/8X$</td> <td>$\leq L$</td> </tr> </tbody> </table> <p>*X=LCD SIDE WIDTH t = GLASS THICKNESS L=ELECTRODE PAD LENGTH ①IF GLASS CHIPPING THE ITO TERMINAL, OVER 2/3 OF THE ITO MUST REMAIN AND BE, INSPECTED ACCORDING TO ELECTRODE TERMINAL SPECIFICATIONS ②IF THE PRODUCT WILL BE HEAT SEALED BY THE CUSTOMER, THE ALIGNMENT MARK MUST NOT BE DAMAGED</p>	a	b	c	$\leq t$	$\leq 1/8X$	$\leq L$					
a	b	c									
$\leq t$	$\leq 1/8X$	$\leq L$									

12.4 RELIABILITY TEST

12.4.1 STANDARD SPECIFICATIONS FOR RELIABILITY OF LCD MODULE

NO.	ITEM	DESCRIPTION
1	HIGH TEMPERATURE OPERATION	THE SAMPLE SHOULD BE ALLOWED TO STAND AT +70°C FOR 240 hrs
2	LOW TEMPERATURE OPERATION	THE SAMPLE SHOULD BE ALLOWED TO STAND AT -20°C FOR 240 hrs
3	HIGH TEMPERATURE STORAGE	THE SAMPLE SHOULD BE ALLOWED TO STAND AT +80°C FOR 240 hrs
4	LOW TEMPERATURE STORAGE	THE SAMPLE SHOULD BE ALLOWED TO STAND AT -30°C FOR 240 hrs
5	HIGH TEMPERATURE / HIGH HUMIDITY STORAGE	THE SAMPLE SHOULD BE ALLOWED TO STAND AT 60°C, 90% RH 240 hrs
6	THERMAL SHOCK (NOT OPERATED)	<p>THE SAMPLE SHOULD BE ALLOWED TO STAND THE FOLLOWING 10 CYCLES OF OPERATION :</p>
7	ESD (ELECTROSTATIC DISCHARGE) (NOT OPERATED)	<p>AIR DISCHARGE ± 12KV CONTACT DISCHARGE ± 8KV (ACCORDING TO IEC-61000-4-2)</p>

NOTE (1) : THE TEST SAMPLES HAVE RECOVERY TIME FOR 2 HOURS AT ROOM TEMPERATURE BEFORE THE FUNCTION CHECK. IN THE STANDARD CONDITIONS, THERE IS NO DISPLAY FUNCTION NG ISSUE OCCURRED.

12.4.2 TESTING CONDITIONS AND INSPECTION CRITERIA

FOR THE FINAL TEST THE TESTING SAMPLE MUST BE STORED AT ROOM TEMPERATURE FOR 24 HOURS, STANDARD SPECIFICATIONS FOR RELIABILITY HAVE BEEN EXECUTED IN ORDER TO ENSURE STABILITY.

NO.	ITEM	TEST MODEL	INSPECTION CRITERIA
1	CURRENT CONSUMPTION	REFER TO SPECIFICATION	THE CURRENT CONSUMPTION SHOULD CONFORM TO THE PRODUCT SPECIFICATION.
2	CONTRAST	REFER TO SPECIFICATION	AFTER THE TESTS HAVE BEEN EXECUTED, THE CONTRAST MUST BE LARGER THAN HALF OF ITS INITIAL VALUE PRIOR TO THE TESTS.
3	APPEARANCE	VISUAL INSPECTION	DEFECT FREE

12.5 OPERATION

- 12.5.1 DO NOT CONNECT OR DISCONNECT MODULES TO OR FROM THE MAIN SYSTEM WHILE POWER IS BEING SUPPLIED.
- 12.5.2 USE THE MODULE WITHIN SPECIFIED TEMPERATURE ; LOWER TEMPERATURE CAUSES THE RETARDATION OF BLINKING SPEED OF THE DISPLAY ; HIGHER TEMPERATURE MAKES OVERALL DISPLAY DISCOLOR. WHEN THE TEMPERATURE RETURNS TO NORMALITY, THE DISPLAY WILL OPERATE NORMALLY.
- 12.5.3 ADJUST THE LC DRIVING VOLTAGE TO OBTAIN THE OPTIMUM CONTRAST.
- 12.5.4 POWER ON SEQUENCE INPUT SIGNALS SHOULD NOT BE SUPPLIED TO LCD MODULE BEFORE POWER SUPPLY VOLTAGE IS APPLIED AND REACHES THE SPECIFIED VALUE AS LISTED IN THE PREVIOUS PAGES OF THE MODULE SPECIFICATION.
IF ABOVE SEQUENCE IS NOT FOLLOWED, CMOS LSI's OF LCD MODULES MAY BE DAMAGED DUE TO LATCH-UP PROBLEM.
- 12.5.5 NOT ALLOWED TO INFLICT ANY EXTERNAL STRESS AND TO CAUSE ANY MECHANICAL INTERFERENCE ON THE BENDING AREA OF FPC DURING THE TAIL BENDING BACKWARDS!
DO NOT STRESS FPC AND IC ON THE MODULE!

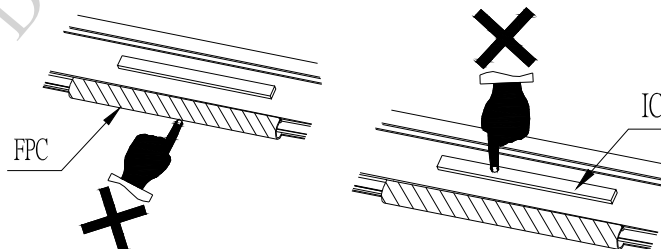

12.6 NOTICE

- 12.6.1 USE A GROUNDED SOLDERING IRON WHEN SOLDERING CONNECTOR I/O TERMINALS . FOR SOLDERING OR REPAIRING, TAKE PRECAUTION AGAINST THE TEMPERATURE OF THE SOLDERING IRON AND THE SOLDERING TIME TO PREVENT PEELING OFF THE THROUGH-HOLE-PAD.
- 12.6.2 DO NOT DISASSEMBLE .EDT SHALL NOT BE HELD RESPONSIBLE IF THE MODULE IS DISASSEMBLED AND UPON THE REASSEMBLY THE MODULE FAILED.
- 12.6.3 DO NOT CHARGE STATIC ELECTRICITY, AS THE CIRCUIT OF THIS MODULE CONTAINS CMOS LSIs. A WORKMAN'S BODY SHOULD ALWAYS BE STATIC-PROTECTED BY USE OF AN ESD STRAP. WORKING CLOTHES FOR SUCH PERSONNEL SHOULD BE OF STATIC-PROTECTED MATERIAL.
- 12.6.4 ALWAYS GROUND THE ELECTRICALLY-POWERED DRIVER BEFORE USING IT TO INSTALL THE LCD MODULE. WHILE CLEANING THE WORK STATION BY VACUUM CLEANER, DO NOT BRING THE SUCKING MOUTH NEAR THE MODULE ; STATIC ELECTRICITY OF THE ELECTRICALLY-POWERED DRIVER OR THE VACUUM CLEANER MAY DESTROY THE MODULE.
- 12.6.5 DON'T GIVE EXTERNAL SHOCK.
- 12.6.6 DON'T APPLY EXCESSIVE FORCE ON THE SURFACE.
- 12.6.7 LIQUID IN LCD IS HAZARDOUS SUBSTANCE. MUST NOT LICK AND SWALLOW.
WHEN THE LIQUID IS ATTACHED TO YOUR, SKIN, CLOTHS ETC. WASH IT OUT THOROUGHLY AND IMMEDIATELY.
- 12.6.8 DON'T OPERATE IT ABOVE THE ABSOLUTE MAXIMUM RATING.
- 12.6.9 STORAGE IN A CLEAN ENVIRONMENT, FREE FROM DUST, ACTIVE GAS, AND SOLVENT.
- 12.6.10 STORE WITHOUT ANY PHYSICAL LOAD.
- 12.6.11 REWIRING : NO MORE THAN 3 TIMES .