

DLC Display Co., Limited

德爾西顯示器有限公司



MODEL No:DLC1040ABG-3

TEL: 86-755-86029824

FAX: 86-755-86029827

E-MAIL: sales@dlcdisplay.com

WEB: www.dlcdisplay.com



Record of Revision

Date	Revision No.	Summary
2015-10-12	1.0	Rev 1.0 was issued
2018-08-30	1.2	Add the order of PIN feet; Page 4 Modify Optical Specification; Page 13

1. Scope

This data sheet is to introduce the specification of DLC1040ABG-3 active matrix 262k color TFT module. It is composed of a color TFT-LCD panel, driver ICs, FPC and a backlight unit. The 10.4" display area contains 800(RGB) x 600 pixels.

2. Application

Digital equipments which need color display outdoor, mobile navigator/video systems.

3. General Information

Item	Contents	Unit
Size	10.4	inch
Resolution	800(RGB) x 600	/
Interface	LVDS	/
Color Depth	262K	/
Technology type	a-si TFT	/
Pixel pitch	0.264 x 0.264	mm
Pixel Configuration	R.G.B. Vertical Stripe	
Outline Dimension (W x H x D)	236.0 x 176.9 x 5.6	mm
Active Area	211.2 x 158.4	mm
Display Mode	TM with Normally White	/
Viewing Direction	12 o'clock	/
Backlight Type	LED Bar	/

4. Outline Drawing

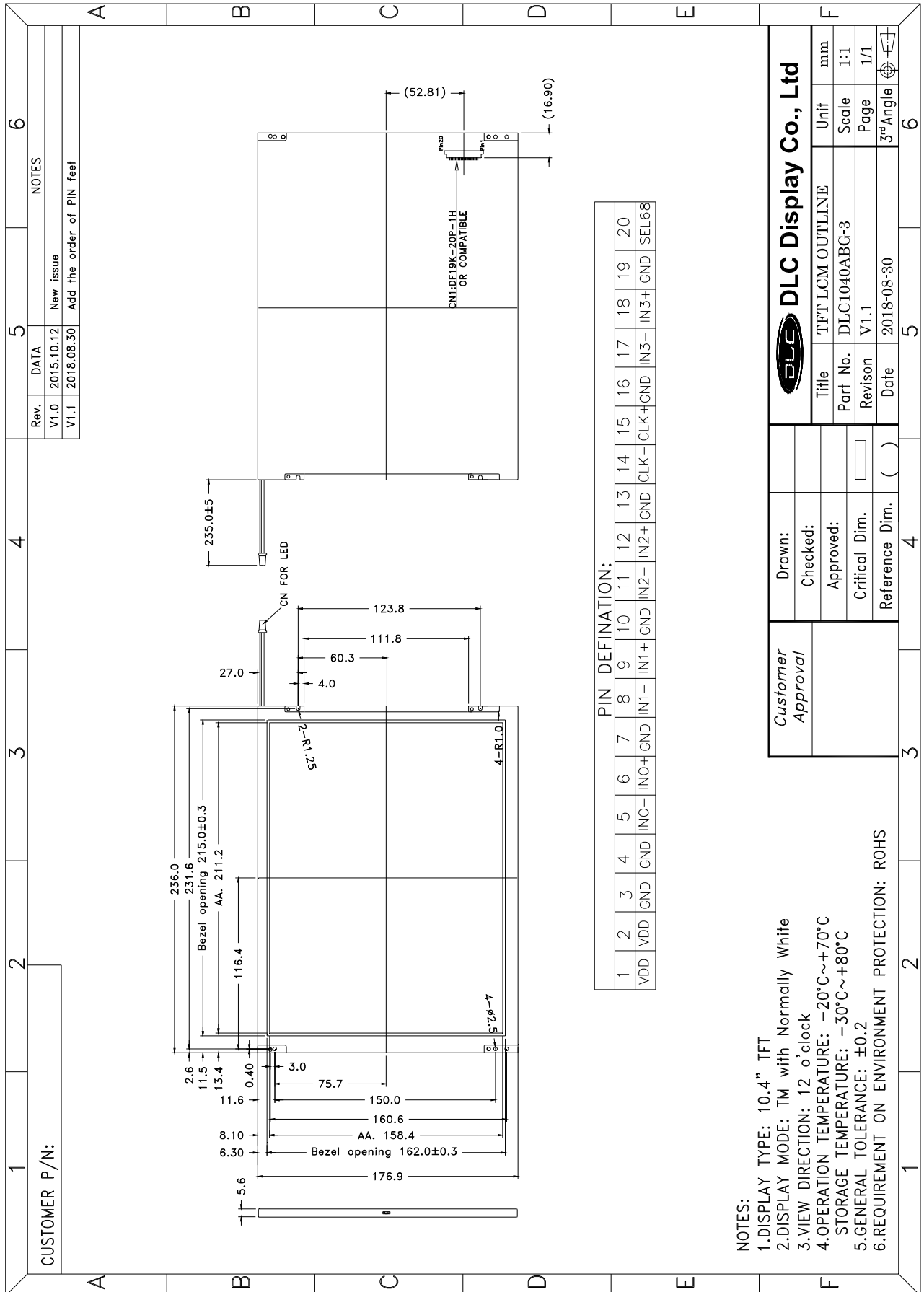

5. Interface signals

No	Symbol	Description	Remarks
1	VDD	Power Supply	
2	VDD	Power Supply	
3	GND	Ground	
4	GND	Ground	
5	IN0-	LVDS receiver negative signal channel 0	
6	IN0+	LVDS receiver positive signal channel 0	
7	GND	Ground	
8	IN1-	LVDS receiver negative signal channel 1	
9	IN1+	LVDS receiver positive signal channel 1	
10	GND	Ground	
11	IN2-	LVDS receiver negative signal channel 2	
12	IN2+	LVDS receiver positive signal channel 2	
13	GND	Ground	
14	CLK-	LVDS receiver negative signal clock	
15	CLK+	LVDS receiver positive signal clock	
16	GND	Ground	
17	IN3-	LVDS receiver negative signal channel 3	
18	IN3+	LVDS receiver positive signal channel 3	
19	GND	Ground	
20	SEL68	6/8bits LVDS data input selection [H: 8bit ; L/NC: 6bit]	

Note1: High stands for "2.7V-3.3V", Low stands for "0-0.4".

Note2: Corresponded connector: Hirose DF19K-20P-1H (56)

Note3: LVDS Input signal

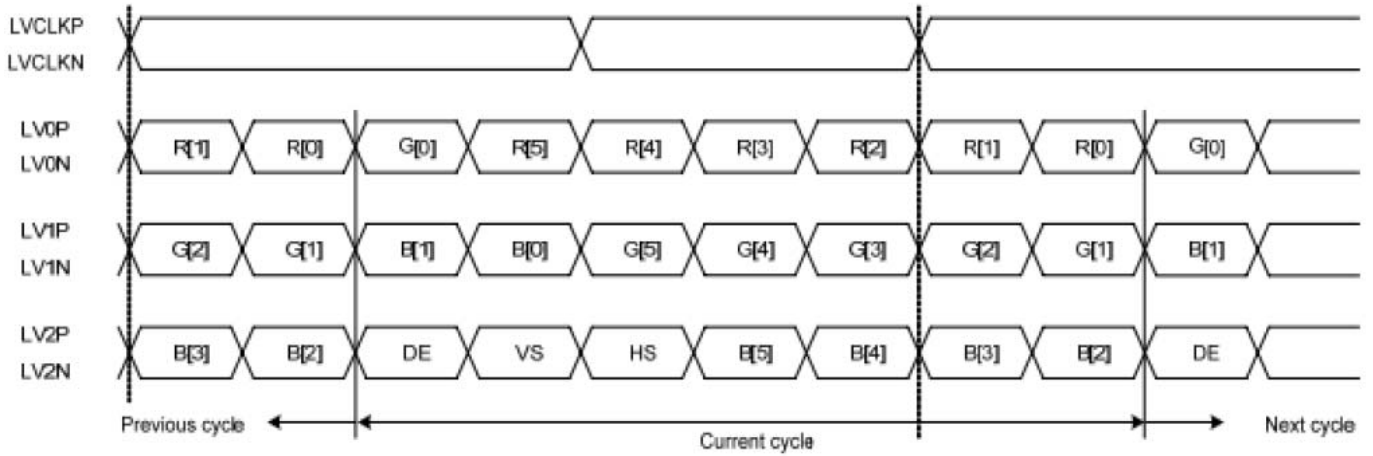

6-bit LVDS input data mapping

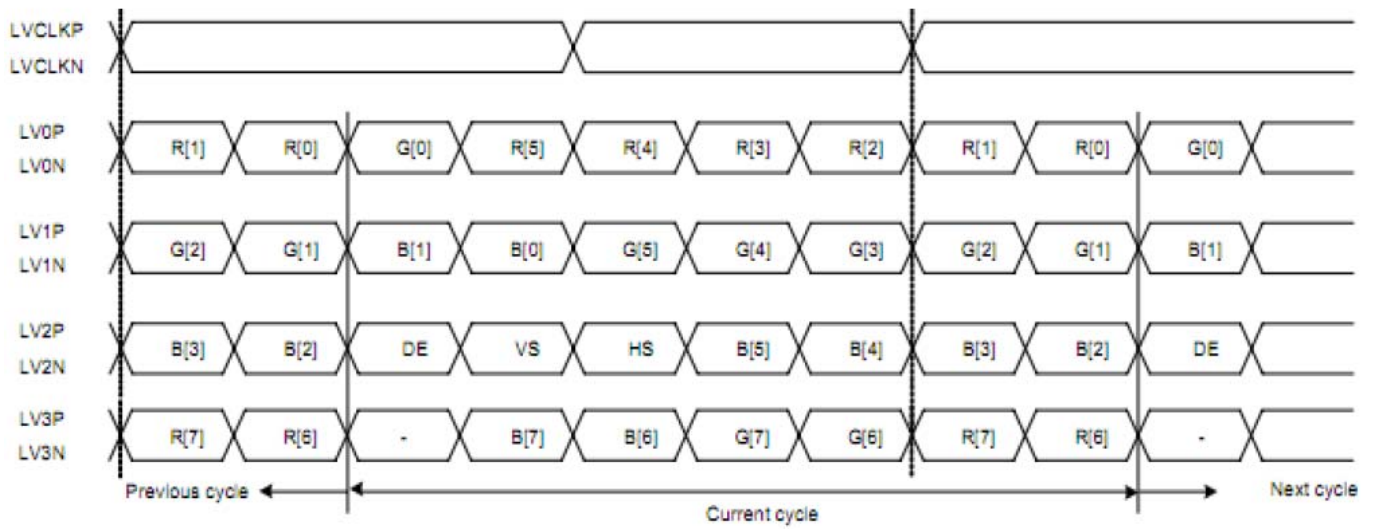

8-bit LVDS input data mapping

6. Absolute maximum Ratings

6.1. Electrical Absolute max. ratings

Parameter	Symbol	MIN	MAX	Unit	Remark
Power Supply Voltage (LCD Module)	VDD	3.0	3.6	V	
Back-light Power Supply Voltage	HV _{DD}	17.7	20.7	V	

6.2. Environment Conditions

Item	Symbol	MIN	MAX	Unit	Remark
Operating Temperature	TOPR	-20	70	°C	
Storage Temperature	TSTG	-30	80	°C	

Note : Temperature and relative humidity range are shown in the figure below.
Wet bulb temperature should be 39 °C max. and no condensation of water.

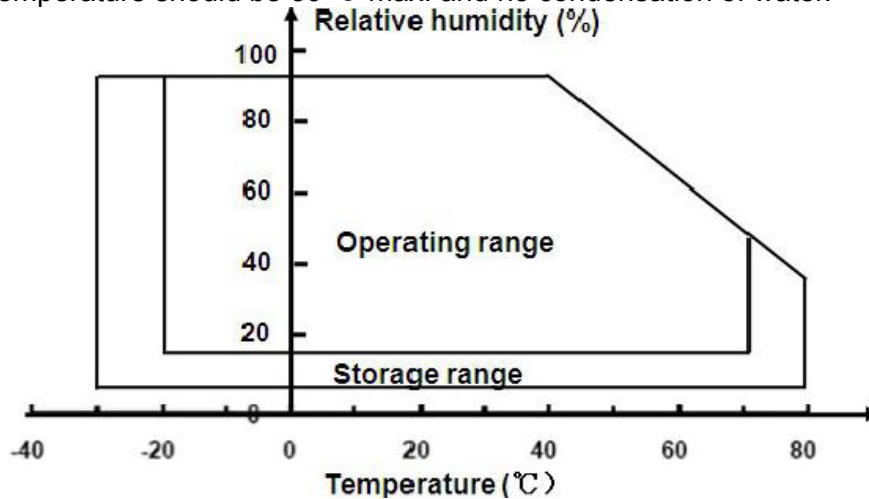

7. Electrical Specifications

7.1 Electrical characteristics

GND=0V, Ta=25°C

Item	Symbol	MIN	TYP	MAX	Unit	Remark
Power Supply Input Voltage	VDD	3.0	3.3	3.6	V	
Power Supply Current	IDD	-	480	-	mA	
Positive-going Input Threshold Voltage	VIT+	-	-	+100	mV	
Negative-going Input Threshold Voltage	VIT-	-100	-	-	mV	
Differential input common mode voltage	Vcom	-	1.2	-	V	

7.2 LED Backlight

Ta=25°C

Item	Symbol	MIN	TYP	MAX	Unit	Remark
LED Forward Voltage	VF	27	-	29	V	
LED Forward Current	IF	-	210	-	mA	
LED Life-Time		-	25,000	-	Hr	IF = 210mA

Notes 1: The LED Life-time define as the estimated time to 50% degradation of initial luminous.

7.3 Block Diagram

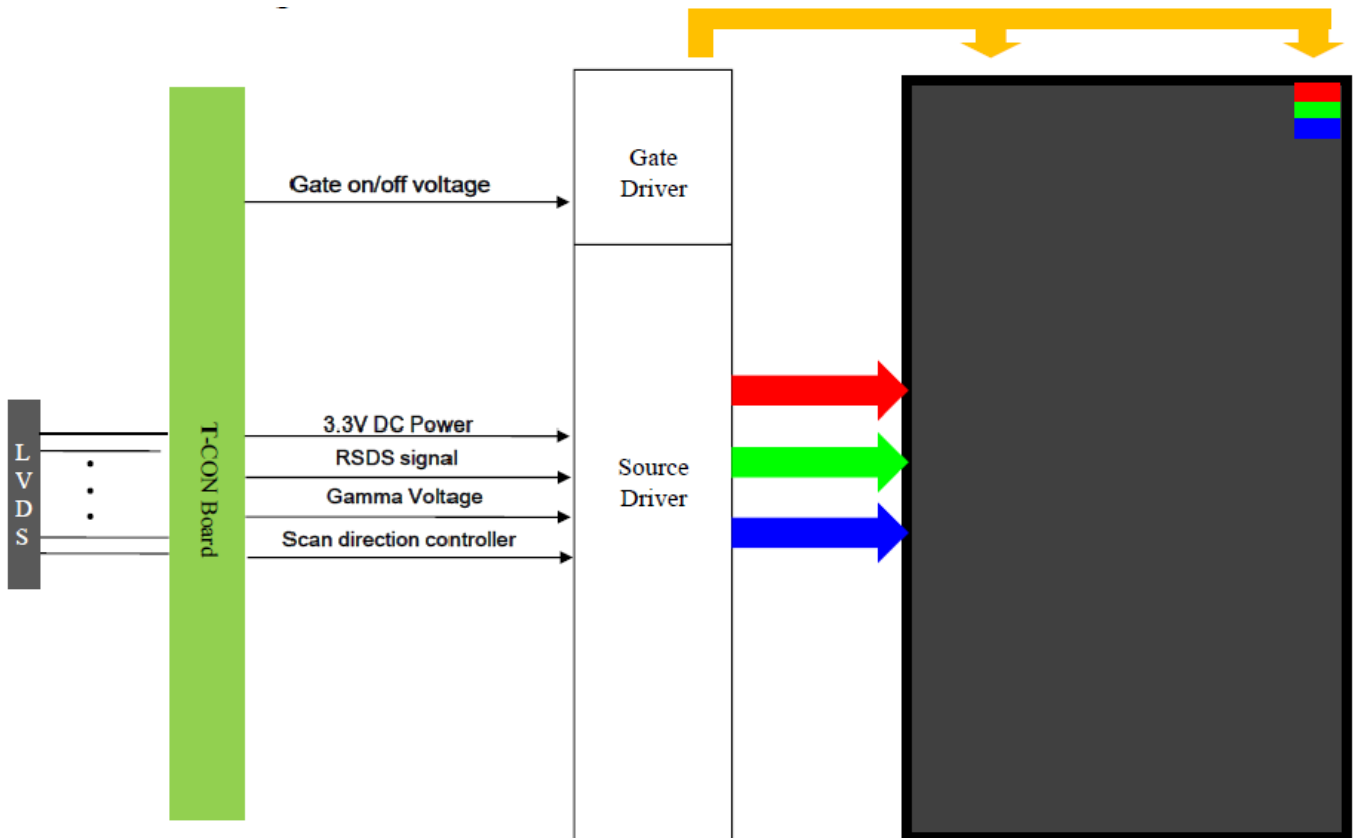

8. Command/AC Timing

DLC1040ABG-3 is operated by the DE only
DE Mode

Parameter	Symbol	Spec			Unit
		Min.	Typ.	Max.	
DCLK Frequency	fclk	32.6	39.6	62.4	MHz
Horizontal Display Area	thd		800		DCLK
HSD Period	th	900	1056	1300	DCLK
HSD Blanking	thb+thfp	90	200	500	DCLK
Vertical Display Area	tvd		600		TH
VSD Period	tv	610	630	800	TH
VSD Blanking	tvbp+tvfp	10	30	200	TH

8.1 LVDS Rx Interface Timing Parameter

Parameter	Symbol	Min.	Typ.	Max.	Unit	Condition
Clock Frequency	RXFCLK	20	-	85	MHz	-
Input data skew margin	TRSKM	-600	-	600	pS	VID =200mV RXVCM=1.2V RXFCLK=65MHz
Clock high time	TLVCH	-	$4/(7 * \text{RXFCLK})$	-	ns	-
Clock low time	TLVCL	-	$3/(7 * \text{RXFCLK})$	-	ns	-
PLL wake-up time	TemPLL	-	-	150	us	-

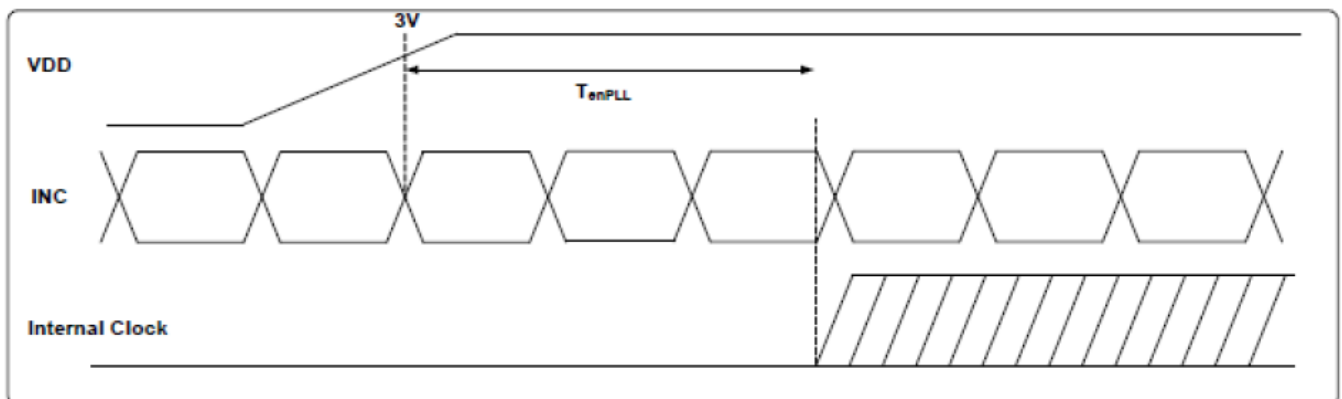
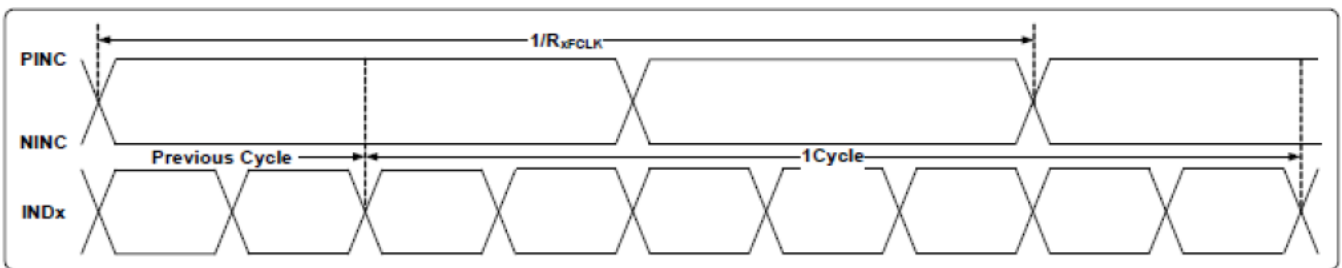

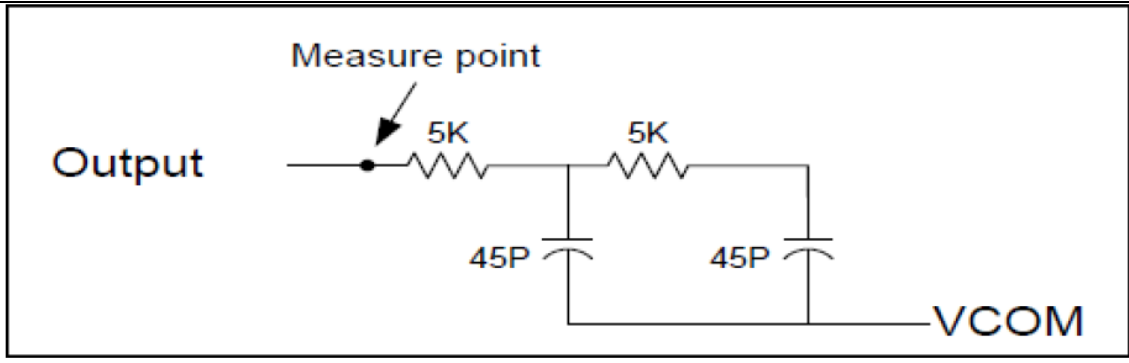

Output load condition

8.3 INPUT SIGNALS, BASIC DISPLAY COLORS & GRAY SCALE OF COLORS

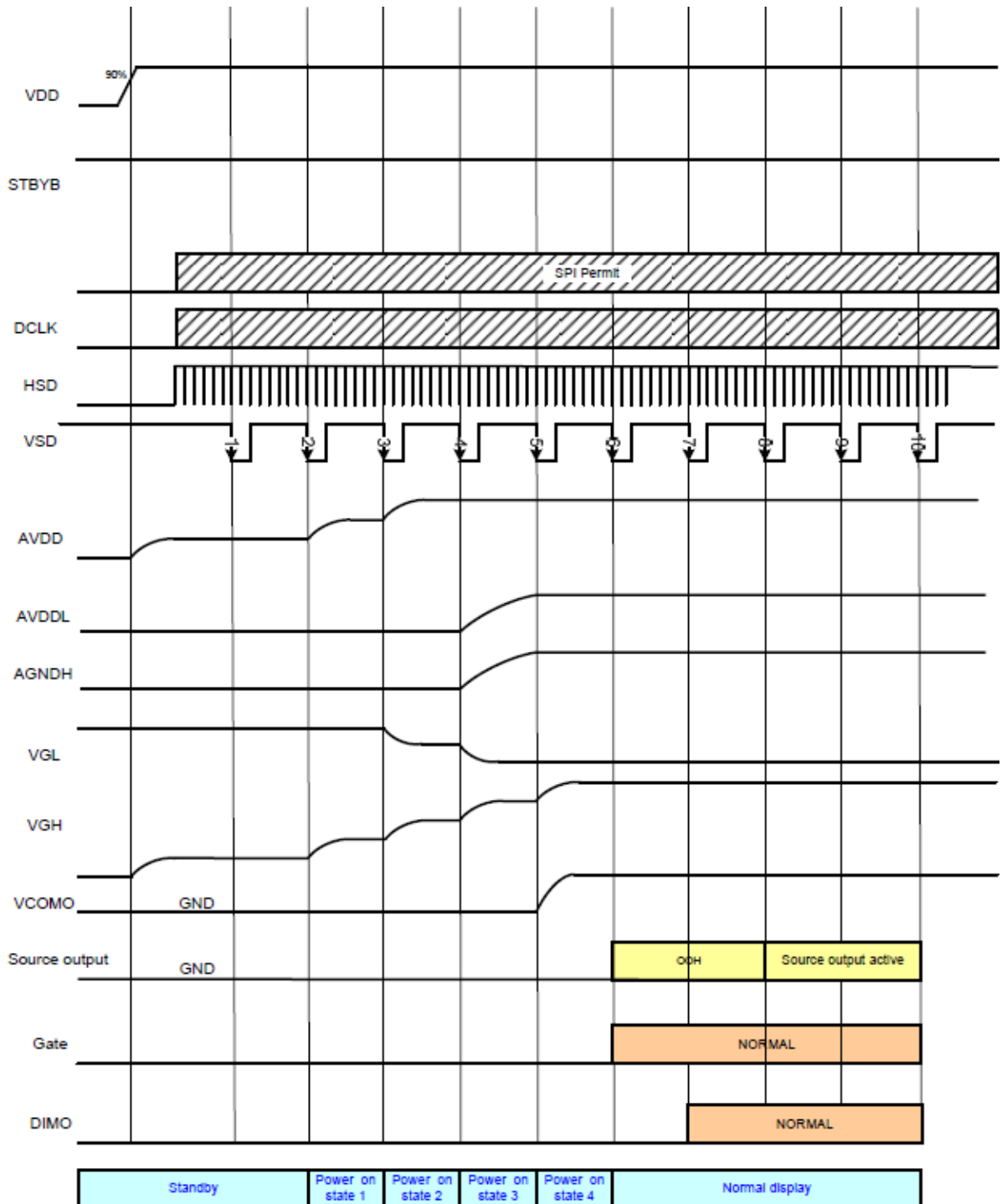

8.4 Power ON/Off Sequence

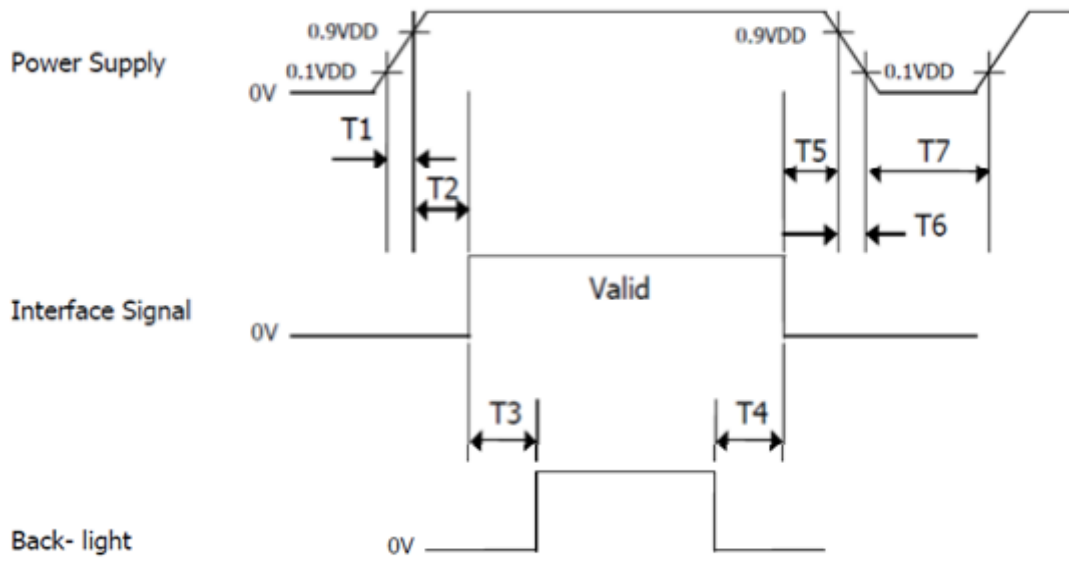

Symbol	Rating			Unit
	MIN	TYP	MAX	
T1	0.5	-	10	ms
T2	0	-	50	ms
T3	200	-	-	ms
T4	200	-	-	ms
T5	0.5	-	50	ms
T6	0	-	10	ms
T7	500	-	-	ms

9. Optical Specification

Backlight is ON

Ta=25°C

Item	Symbol	Condition	Min	Typ.	Max.	Unit	Remark
Contrast Ratio	CR	$\theta=0^\circ$	600	800	--		Note1 Note3
Response Time	Ton/ Toff	25°C	--	30	--	ms	Note1 Note4
View Angles	ΘT	$CR \geq 10$	50	60	--	Degree	Note 2
	ΘB		60	70	--		
	ΘL		60	70	--		
	ΘR		60	70	--		
Chromaticity	White	Brightness is on	x	0.269	0.299	0.329	Note5, Note1
			y	0.309	0.339	0.369	
	Red		x	0.579	0.609	0.639	
			y	0.305	0.335	0.365	
	Green		x	0.299	0.329	0.359	
			y	0.525	0.555	0.585	
	Blue		x	0.118	0.148	0.178	
			y	0.072	0.102	0.132	
Uniformity	U		70	80	--	%	Note1 Note6
NTSC	S		--	50	--	%	Note 5
Luminance	L		--	1000	--	cd/m ²	Note1 Note7

Test condition: The ambient temperature is 25±2 .humidity is 65±7%

Note 1: Definition of optical measurement system.

Temperature = 25°C(±3°C)

LED back-light: ON, Environment brightness < 150 lx

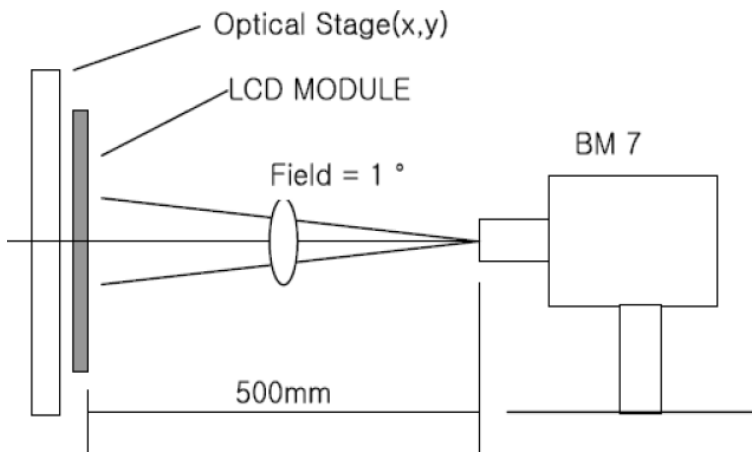

Note 2: Viewing angle range is defined as follow:

Viewing angle is measured at the center point of the LCD.

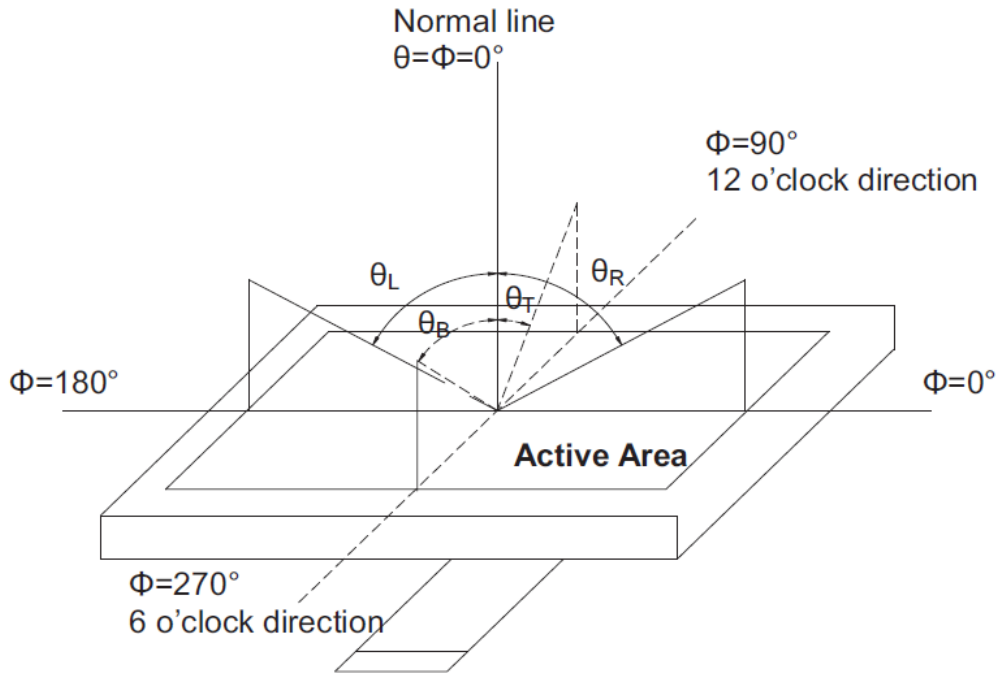

Note 3: Contrast ratio is defined as follow:

$$\text{Contrast Ratio} = \frac{\text{Surface Luminance with all white pixels}}{\text{Surface Luminance with all black pixels}}$$

Note 4: Response time is defined as follow:

Response time is the time required for the display to transition from black to white (Rise Time, Tr) and from white to black(Decay Time, Tf).

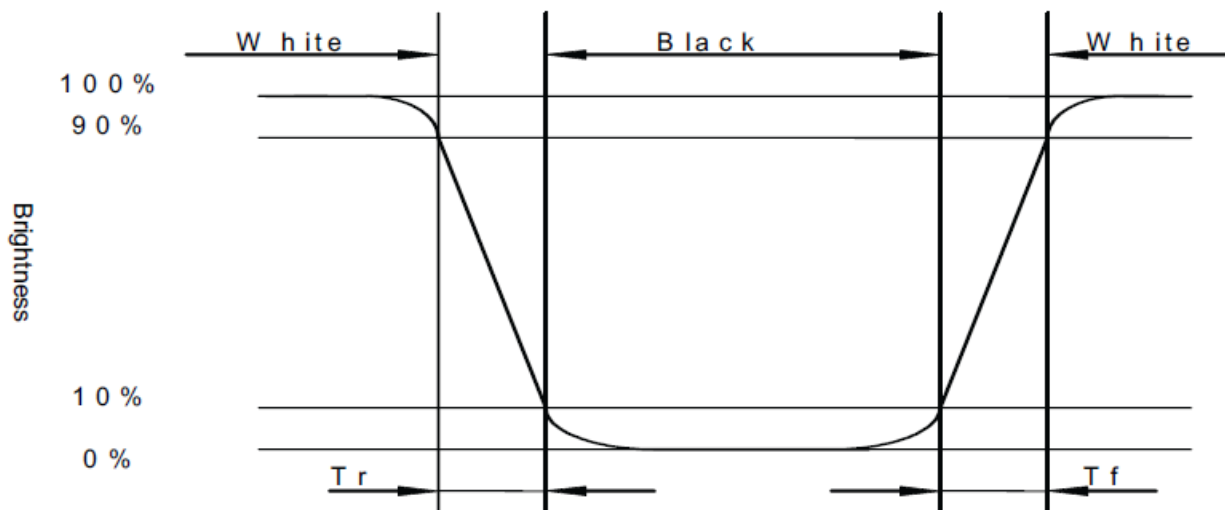

Note 5: Color chromaticity is defined as follow: (CIE1931)

Color coordinates measured at center point of LCD.

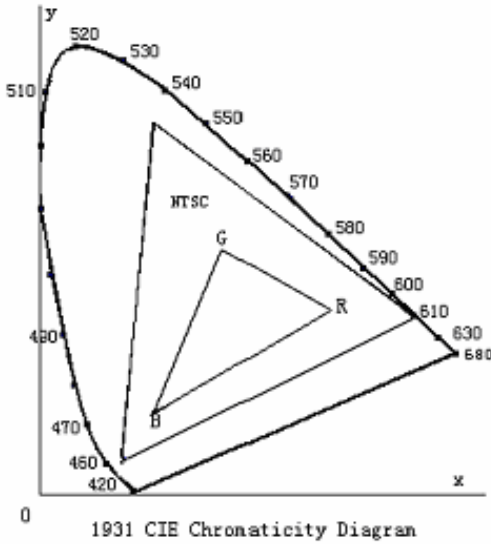

$$S = \frac{\text{area of RGB triangle}}{\text{area of NTSC triangle}} \times 100\%$$

Note 6: Luminance Uniformity is defined as follow:

Active area is divided into 9 measuring areas (Refer Fig. 2). Every measuring point is placed at the center of each measuring area.

$$\text{Uniformity (U)} = \frac{\text{Minimum Luminance(brightness) in 9 points}}{\text{Maximum Luminance(brightness) in 9 points}}$$

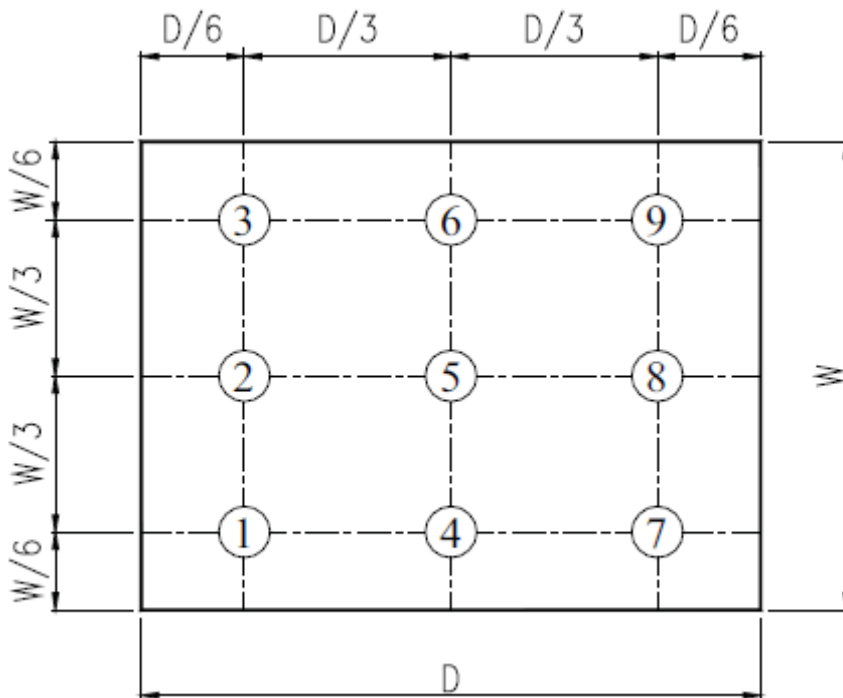

Fig. 2 Definition of uniformity

Note 7: Luminance is defined as follow:

Luminance is defined as the brightness of all pixels “White” at the center of display area on optimum contrast.

10. Environmental / Reliability Tests

No	Test Item	Condition	Judgment criteria
1	High Temp Operation	Ts=+70°C, 240hrs	Per table in below
2	Low Temp Operation	Ta=-20°C, 240hrs	Per table in below
3	High Temp Storage	Ta=+80°C, 240hrs	Per table in below
4	Low Temp Storage	Ta=-30°C, 240hrs	Per table in below
5	High Temp & High Humidity Storage	Ta=+60°C, 90% RH 240 hours	Per table in below (polarizer discoloration is excluded)
6	Thermal Shock (Non-operation)	-20°C 30 min~+70°C 30 min, Change time:5min, 10 Cycles	Per table in below
7	ESD (Operation)	C=150pF, R=330Ω · 5points/panel Air:±15KV, 5times; Contact:±8KV, 5 times;	Per table in below
8	Vibration (Non-operation)	Frequency range:10~55Hz, Stroke:1.5mm Sweep:10Hz~55Hz~10Hz 2 hours for each direction of X.Y.Z.	Per table in below
9	Shock (Non-operation)	60G 6ms, ±X,±Y,±Z 3times, for each direction	Per table in below
10	Package Drop Test	Height:60 cm, 1 corner, 3 edges, 6 surfaces	Per table in below

INSPECTION	CRITERION(after test)
Appearance	No Crack on the FPC, on the LCD Panel
Alignment of LCD Panel	No Bubbles in the LCD Panel No other Defects of Alignment in Active area
Electrical current	Within device specifications
Function / Display	No Broken Circuit, No Short Circuit or No Black line No Other Defects of Display

11. Precautions for Use of LCD Modules

11.1 Safety

The liquid crystal in the LCD is poisonous. Do not put it in your mouth. If the liquid crystal touches your skin or clothes, wash it off immediately using soap and water.

11.2 Handling

- A. The LCD and touch panel is made of plate glass. Do not subject the panel to mechanical shock or to excessive force on its surface.
- B. Do not handle the product by holding the flexible pattern portion in order to assure the reliability
- C. Transparency is an important factor for the touch panel. Please wear clear finger sacks, gloves and mask to protect the touch panel from finger print or stain and also hold the portion outside the view area when handling the touch panel.
- D. Provide a space so that the panel does not come into contact with other components.
- E. To protect the product from external force, put a covering lens (acrylic board or similar board) and keep an appropriate gap between them.
- F. Transparent electrodes may be disconnected if the panel is used under environmental conditions where dew condensation occurs.
- G. Property of semiconductor devices may be affected when they are exposed to light, possibly resulting in IC malfunctions.
- H. To prevent such IC malfunctions, your design and mounting layout shall be done in the way that the IC is not exposed to light in actual use.

11.3 Static Electricity

- A. Ground soldering iron tips, tools and testers when they are in operation.
- B. Ground your body when handling the products.
- C. Power on the LCD module before applying the voltage to the input terminals.
- D. Do not apply voltage which exceeds the absolute maximum rating.
- E. Store the products in an anti-electrostatic bag or container.

11.4 Storage

- A. Store the products in a dark place at $+25^{\circ}\text{C}\pm 10^{\circ}\text{C}$ with low humidity (40% RH to 60% RH). Don't expose to sunlight or fluorescent light.
- B. Storage in a clean environment, free from dust, active gas, and solvent.

11.5 Cleaning

- A. Do not wipe the touch panel with dry cloth, as it may cause scratch.
- B. Wipe off the stain on the product by using soft cloth moistened with ethanol. Do not allow ethanol to get in between the upper film and the bottom glass. It may cause peeling issue or defective operation. Do not use any organic solvent or detergent other than ethanol.

11.6 Cautions for installing and assembling

- A. Bezel edge must be positioned in the area between the Active area and View area. The bezel may press the touch screen and cause activation if the edge touches the active area. A gap of approximately 0.5mm is needed between the bezel and the top electrode. It may cause unexpected activation if the gap is too narrow. There is a tolerance of 0.2 to 0.3mm for the outside dimensions of the touch panel and tail. A gap must be made to absorb the tolerance in the case and connector.
- B. In order to make the display assembly stable and firm, DLC recommends to design some supporting at the display backside, especially for the display with tape-attached touch panel, such supporting is important and essential, or else, the display may drop-off from front after some period of time.
- C. Do not display the fixed pattern for a long time because it may develop image sticking due to the LCD structure. If the screen is displayed with fixed pattern, use a screen saver.

