

**DLC Display Co., Limited**

德爾西顯示器有限公司



MODEL No: DLC1210HIG

TEL: 86-755-86029824

FAX: 86-755-86029827

E-MAIL: [sales@dlcdisplay.com](mailto:sales@dlcdisplay.com)

WEB: [www.dlcdisplay.com](http://www.dlcdisplay.com)



### Record of Revision

Date	Revision No.	Summary
2013-04-25	1.0	Rev 1.0 was issued

### 1. Scope

This data sheet is to introduce the specification of DLC1210HIG active matrix TFT module. It is composed of a color TFT-LCD panel, driver ICs, FPC and a backlight unit. The 12.1" display area contains 800(RGB) x 600 pixels.

### 2. Application

Digital equipments which need color display, MID, mobile navigator/video systems.

### 3. General Information

Item	Contents	Unit
Size	12.1	inch
Resolution	800(RGB) x 600	/
Interface	LVDS	/
Technology type	a-Si TFT	/
Pixel pitch	0.3075x0.3075	mm
Pixel Configuration	RGB Vertical stripe	
Outline Dimension (W x H x D)	260.5x204.0x8.4	mm
Active Area	246.00x 184.50	mm
Display Mode	Transmissive Normally Black	/
Backlight Type	LED	/
Weight	506	g

### 4. Outline Drawing

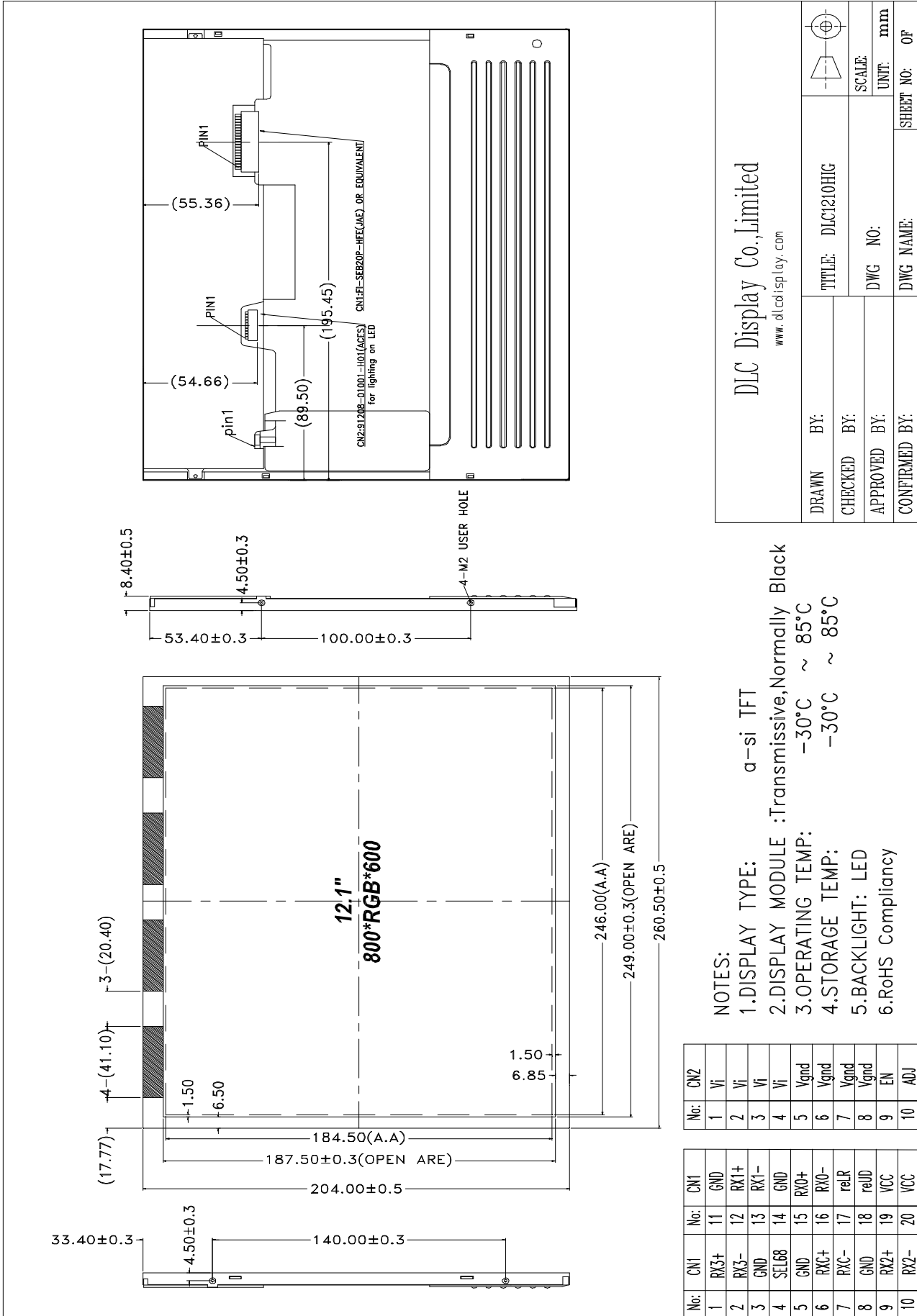

**DLC Display Co., Limited**  
www.dlcdisplay.com

DRAWN BY:	TITLE: DLC1210HIG		SCALE:
CHECKED BY:	DWG NO:	UNIT: mm	
APPROVED BY:	DWG NAME:	SHEET NO. OF	
CONFIRMED BY:			

- NOTES:**
- 1.DISPLAY TYPE: α-si TFT
  - 2.DISPLAY MODULE :Transmissive,Normally Black
  - 3.OPERATING TEMP: -30°C ~ 85°C
  - 4.STORAGE TEMP: -30°C ~ 85°C
  - 5.BACKLIGHT: LED
  - 6.RoHS Compliance

No:	CN1	No:	CN1	No:	CN2
1	RX3+	11	GND	1	V <sub>i</sub>
2	RX3-	12	RX1+	2	V <sub>i</sub>
3	GND	13	RX1-	3	V <sub>i</sub>
4	SEL68	14	GND	4	V <sub>i</sub>
5	GND	15	RX0+	5	V <sub>gnd</sub>
6	RXC+	16	RX0-	6	V <sub>gnd</sub>
7	RXC-	17	reLR	7	V <sub>gnd</sub>
8	GND	18	reLD	8	V <sub>gnd</sub>
9	RX2+	19	VCC	9	EN
10	RX2-	20	VCC	10	ADJ

## 5. Interface signals

### TFT LCD MODULE

No	Symbol	Description	Remarks
1	RX3+	Differential Data Input, CH3 ( Positive )	
2	RX3-	Differential Data Input, CH3 (Negative )	
3	GND	Power ground	
4	SEL68	LVDS 6/8 bit select function control, Low or NC→6 bit Input Mode High→8bit Input Mode	Note (3)
5	GND	Power ground	
6	RXC+	Differential Clock Input ( Positive )	
7	RXC-	Differential Clock Input ( Negative )	
8	GND	Power ground	
9	RX2+	Differential Data Input , CH2 ( Positive )	
10	RX2-	Differential Data Input , CH2 ( Negative )	
11	GND	Power ground	
12	RX1+	Differential Data Input , CH1 ( Positive )	
13	RX1-	Differential Data Input, CH1 ( Negative )	
14	GND	Power ground	
15	RX0+	Differential Data Input, CH0 ( Positive )	
16	RX0-	Differential Data Input, CH0 (Negative )	
17	reLR	Horizontal Reverse Scan Control, Low or NC→ Normal Mode. High →Horizontal Reverse Scan	Note (3)
18	reUD	Vertical Reverse Scan Control, Low or NC→ Normal Mode, High → Vertical Reverse Scan	Note (3)
19	VCC	Power supply	
20	VCC	Power supply	

Note (1) Connector Part No.: FI-SEB20P-HFE(JAE) or 076B20-0048RA-G4(STARCONN) or equivalent.

Note (2) User's connector Part No.: FI-SE20ME(JAE) or equivalent

Note (3) "Low" stands for 0V. "High" stands for 3.3V. "NC" stands for "No Connected".

## BACKLIGHT UNIT(Converter connector pin)

No	Symbol	Description	Remarks
1	$V_i$	Converter input voltage	12V
2	$V_i$	Converter input voltage	12V
3	$V_i$	Converter input voltage	12V
4	$V_i$	Converter input voltage	12V
5	$V_{GND}$	Converter ground	Ground
6	$V_{GND}$	Converter ground	Ground
7	$V_{GND}$	Converter ground	Ground
8	$V_{GND}$	Converter ground	Ground
9	EN	Enable pin	3.3V
10	ADJ	Backlight Adjust	PWM Dimming (190-210Hz, Hi: 3.3V <sub>DC</sub> , Lo: 0V <sub>DC</sub> )

Note (1) Connector Part No.: 91208-01001-H01 (ACES) or equivalent.

Note (2) User's connector Part No.: 91209-01011 (ACES) or equivalent



Color Data Input Assignment

The brightness of each primary color (red, green and blue) is based on the 6-bit gray scale data input for the color. The higher the binary input, the brighter the color. The table below provides the assignment of color versus data input.

Color		Data Signal																	
		Red						Green						Blue					
		R5	R4	R3	R2	R1	R0	G5	G4	G3	G2	G1	G0	B5	B4	B3	B2	B1	B0
Basic Colors	Black	0	0	0	0	0	0	0	0	0	0	0	0	0	0	0	0	0	0
	Red	1	1	1	1	1	1	0	0	0	0	0	0	0	0	0	0	0	0
	Green	0	0	0	0	0	0	1	1	1	1	1	1	0	0	0	0	0	0
	Blue	0	0	0	0	0	0	0	0	0	0	0	0	1	1	1	1	1	1
	Cyan	0	0	0	0	0	0	1	1	1	1	1	1	1	1	1	1	1	1
	Magenta	1	1	1	1	1	1	0	0	0	0	0	0	1	1	1	1	1	1
	Yellow	1	1	1	1	1	1	1	1	1	1	1	1	0	0	0	0	0	0
	White	1	1	1	1	1	1	1	1	1	1	1	1	1	1	1	1	1	1
Gray Scale Of Red	Red(0)/Dark	0	0	0	0	0	0	0	0	0	0	0	0	0	0	0	0	0	0
	Red(1)	0	0	0	0	0	1	0	0	0	0	0	0	0	0	0	0	0	0
	Red(2)	0	0	0	0	1	0	0	0	0	0	0	0	0	0	0	0	0	0
	...	...	...	...	...	...	...	...	...	...	...	...	...	...	...	...	...	...	...
	...	...	...	...	...	...	...	...	...	...	...	...	...	...	...	...	...	...	...
	Red(61)	1	1	1	1	0	1	0	0	0	0	0	0	0	0	0	0	0	0
	Red(62)	1	1	1	1	1	0	0	0	0	0	0	0	0	0	0	0	0	0
	Red(63)	1	1	1	1	1	1	0	0	0	0	0	0	0	0	0	0	0	0
Gray Scale Of Green	Green(0)/Dark	0	0	0	0	0	0	0	0	0	0	0	0	0	0	0	0	0	0
	Green(1)	0	0	0	0	0	0	0	0	0	0	0	1	0	0	0	0	0	0
	Green(2)	0	0	0	0	0	0	0	0	0	0	1	0	0	0	0	0	0	0
	...	...	...	...	...	...	...	...	...	...	...	...	...	...	...	...	...	...	...
	...	...	...	...	...	...	...	...	...	...	...	...	...	...	...	...	...	...	...
	Green(61)	0	0	0	0	0	0	1	1	1	1	0	1	0	0	0	0	0	0
	Green(62)	0	0	0	0	0	0	1	1	1	1	1	0	0	0	0	0	0	0
	Green(63)	0	0	0	0	0	0	1	1	1	1	1	1	0	0	0	0	0	0
Gray Scale Of Blue	Blue(0)/Dark	0	0	0	0	0	0	0	0	0	0	0	0	0	0	0	0	0	0
	Blue(1)	0	0	0	0	0	0	0	0	0	0	0	0	0	0	0	0	0	1
	Blue(2)	0	0	0	0	0	0	0	0	0	0	0	0	0	0	0	0	1	0
	...	...	...	...	...	...	...	...	...	...	...	...	...	...	...	...	...	...	...
	...	...	...	...	...	...	...	...	...	...	...	...	...	...	...	...	...	...	...
	Blue(61)	0	0	0	0	0	0	0	0	0	0	0	0	1	1	1	1	0	1
	Blue(62)	0	0	0	0	0	0	0	0	0	0	0	0	1	1	1	1	1	0
	Blue(63)	0	0	0	0	0	0	0	0	0	0	0	0	1	1	1	1	1	1

Note (1) 0: Low Level Voltage, 1: High Level Voltage



The brightness of each primary color (red, green and blue) is based on the 8-bit gray scale data input for the color. The higher the binary input, the brighter the color. The table below provides the assignment of color versus data input.

Color		Data Signal																							
		Red								Green								Blue							
		R7	R6	R5	R4	R3	R2	R1	R0	G7	G6	G5	G4	G3	G2	G1	G0	B7	B6	B5	B4	B3	B2	B1	B0
Basic Colors	Black	0	0	0	0	0	0	0	0	0	0	0	0	0	0	0	0	0	0	0	0	0	0	0	
	Red	1	1	1	1	1	1	1	1	0	0	0	0	0	0	0	0	0	0	0	0	0	0	0	
	Green	0	0	0	0	0	0	0	0	1	1	1	1	1	1	1	1	0	0	0	0	0	0	0	
	Blue	0	0	0	0	0	0	0	0	0	0	0	0	0	0	0	0	1	1	1	1	1	1	1	
	Cyan	0	0	0	0	0	0	0	0	1	1	1	1	1	1	1	1	1	1	1	1	1	1	1	
	Magenta	1	1	1	1	1	1	1	1	0	0	0	0	0	0	0	0	1	1	1	1	1	1	1	
	Yellow	1	1	1	1	1	1	1	1	1	1	1	1	1	1	1	1	0	0	0	0	0	0	0	
	White	1	1	1	1	1	1	1	1	1	1	1	1	1	1	1	1	1	1	1	1	1	1	1	
Gray Scale Of Red	Red(0) / Dark	0	0	0	0	0	0	0	0	0	0	0	0	0	0	0	0	0	0	0	0	0	0		
	Red(1)	0	0	0	0	0	0	0	1	0	0	0	0	0	0	0	0	0	0	0	0	0	0		
	Red(2)	0	0	0	0	0	0	1	0	0	0	0	0	0	0	0	0	0	0	0	0	0	0		
	:	:	:	:	:	:	:	:	:	:	:	:	:	:	:	:	:	:	:	:	:	:	:		
	:	:	:	:	:	:	:	:	:	:	:	:	:	:	:	:	:	:	:	:	:	:	:		
	Red(253)	1	1	1	1	1	1	0	1	0	0	0	0	0	0	0	0	0	0	0	0	0	0		
	Red(254)	1	1	1	1	1	1	1	0	0	0	0	0	0	0	0	0	0	0	0	0	0	0		
	Red(255)	1	1	1	1	1	1	1	1	0	0	0	0	0	0	0	0	0	0	0	0	0	0		
Gray Scale Of Green	Green(0)/ Dark	0	0	0	0	0	0	0	0	0	0	0	0	0	0	0	0	0	0	0	0	0	0		
	Green(1)	0	0	0	0	0	0	0	0	0	0	0	0	0	0	1	0	0	0	0	0	0	0		
	Green(2)	0	0	0	0	0	0	0	0	0	0	0	0	0	0	1	0	0	0	0	0	0	0		
	:	:	:	:	:	:	:	:	:	:	:	:	:	:	:	:	:	:	:	:	:	:	:		
	:	:	:	:	:	:	:	:	:	:	:	:	:	:	:	:	:	:	:	:	:	:	:		
	Green(253)	0	0	0	0	0	0	0	0	1	1	1	1	1	1	0	1	0	0	0	0	0	0		
	Green(254)	0	0	0	0	0	0	0	0	1	1	1	1	1	1	1	0	0	0	0	0	0	0		
	Green(255)	0	0	0	0	0	0	0	0	1	1	1	1	1	1	1	1	0	0	0	0	0	0		
Gray Scale Of Blue	Blue(0) / Dark	0	0	0	0	0	0	0	0	0	0	0	0	0	0	0	0	0	0	0	0	0	0		
	Blue(1)	0	0	0	0	0	0	0	0	0	0	0	0	0	0	0	0	0	0	0	0	0	1		
	Blue(2)	0	0	0	0	0	0	0	0	0	0	0	0	0	0	0	0	0	0	0	0	0	1		
	:	:	:	:	:	:	:	:	:	:	:	:	:	:	:	:	:	:	:	:	:	:	:		
	:	:	:	:	:	:	:	:	:	:	:	:	:	:	:	:	:	:	:	:	:	:	:		
	Blue(253)	0	0	0	0	0	0	0	0	0	0	0	0	0	0	0	1	1	1	1	1	1	0		
	Blue(254)	0	0	0	0	0	0	0	0	0	0	0	0	0	0	0	1	1	1	1	1	1	0		
	Blue(255)	0	0	0	0	0	0	0	0	0	0	0	0	0	0	0	1	1	1	1	1	1	1		

Note (1) 0: Low Level Voltage, 1: High Level Voltage

## 6. Absolute maximum Ratings

### 6.1. Electrical Absolute max. ratings

Parameter	Symbol	MIN	MAX	Unit	Remark
Logic Supply Voltage	VDD	-0.3	7	V	

### 6.2. Environment Conditions

Item	Symbol	MIN	MAX	Unit	Remark
Operating Temperature	TOPR	-30	85	°C	
Storage Temperature	TSTG	-30	85	°C	

### 6.3 Back-light Unit

Item	Symbol	MIN	MAX	Unit	Remark
Converter voltage	Vi	-0.3	18	V	Note1,2
Enable voltage	EN	---	5.5	V	
Backlight adjust	ADJ	---	5.5	V	

Note (1) Permanent damage to the device may occur if maximum values are exceeded. Function operation should be restricted to the conditions described under Normal Operating Conditions.

Note (2) Specified values are for lamp (Refer to 5.2 for further information).

## 7. Electrical Specifications

### 7.1 Electrical characteristics

GND=0V, Ta=25°C

Item	Symbol	MIN	TYP	MAX	Unit	Remark
Power Supply Voltage	Vcc	3.0	3.3	3.6	V	(1) at Vcc=3.3V
		4.75	5.0	5.25	V	(1) at Vcc=5.0V
Rush current	IRUSH	-	-	1.5	A	(2)
Power supply current	White	-	450	540	mA	(3)a, at vcc=3.3V
		-	310	370	mA	(3)a, at vcc=5.0V
	Black	-	420	480	mA	(3)a, at vcc=3.3V
		-	280	335	mA	(3)a, at vcc=5.0V
Power Consumption	PL	-	1.49	1.78	W	-
LVDS differential input voltage	VID	100	-	600	mV	-
LVDS common input voltage	VICM	0.7	-	1.6	V	-

Note (1) The assembly should be always operated within above ranges.

Note (2) Measurement Conditions:

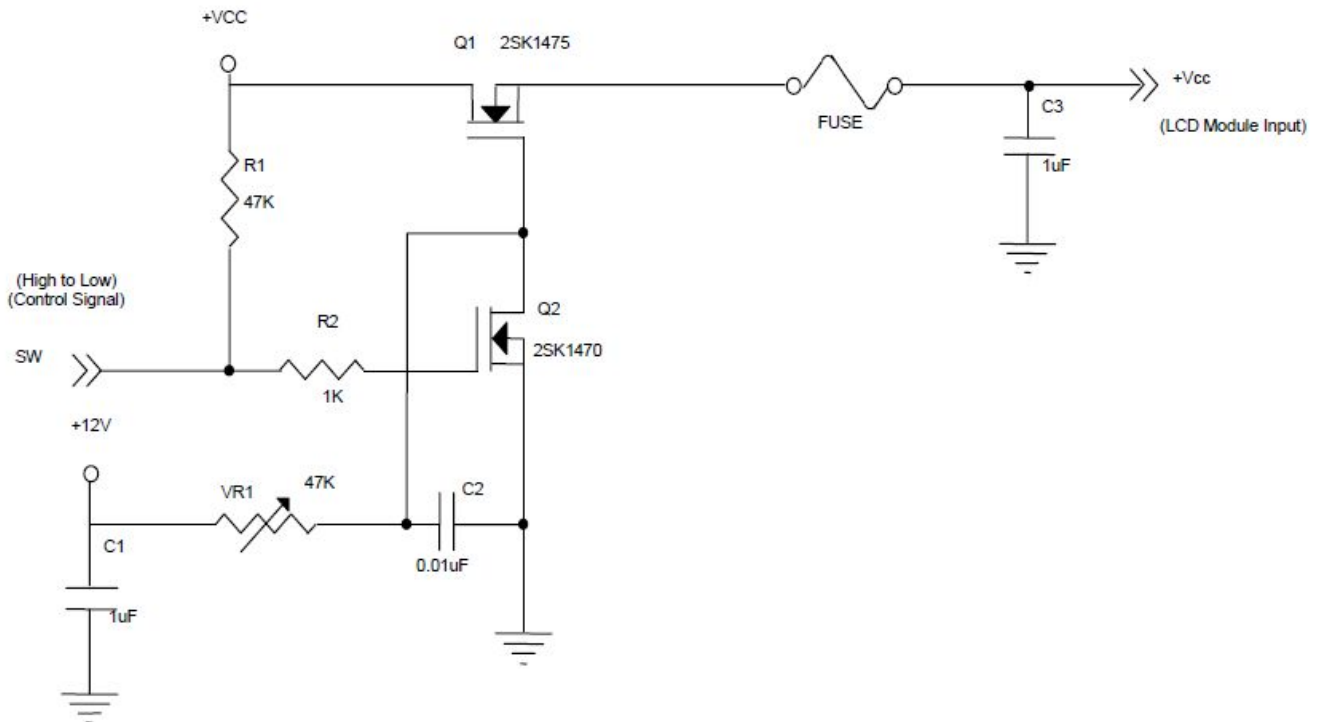

Vcc rising time is 470μs

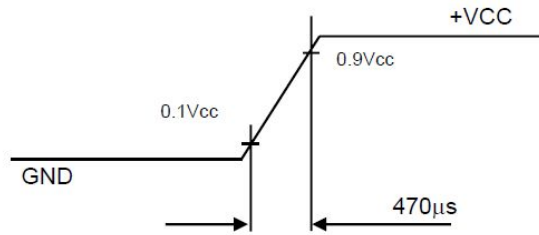

Note (3) The specified power supply current is under the conditions at V<sub>cc</sub> = 3.3V or 5V, T<sub>a</sub> = 25 ± 2 °C, f<sub>v</sub> = 60 Hz, whereas a power dissipation check pattern below is displayed.

a. White Pattern

b. Black Pattern



Active Area



Active Area

## 7.2 LED Backlight

T<sub>a</sub>=25°C

Item	Symbol	MIN	TYP	MAX	Unit	Remark	
Converter Power Supply Voltage	V <sub>i</sub>	10.8	12.0	13.2	V	(Duty 100%)	
Converter Power Supply Current	I <sub>i</sub>	--	0.53	--	A	(1) V <sub>i</sub> = 12V (Duty 100%)	
Converter Power Consumption	P <sub>i</sub>	--	6.4	--	W	(1)V <sub>i</sub> = 12V (Duty 100%)	
EN Control Level	Backlight on	-	2.0	3.3	5.0	V	
	Backlight off	-	0	--	0.8	V	
PWM Control Level	PWM high level	-	2.0	3.3	5.0	V	
	PWM low level	-	0	-	0.15	V	
PWM Control Duty Ratio	-	1	-	100	%		
PWM Control Frequency	f <sub>PWM</sub>	190	200	210	Hz		
LED Life Time	-	50000	-	-	Hrs	(2)	

Note (1) LED current is measured by utilizing a high frequency current meter as shown below:

Note (2) The lifetime of LED is defined as the time when it continues to operate under the conditions at  $T_a = 25 \pm 2 \text{ }^\circ\text{C}$  and  $I_{LED} = 55\text{mA DC}$  (LED forward current) until the brightness becomes  $\cong 50\%$  of its original value. Operating LED under high temperature environment will reduce life time and lead to color shift.

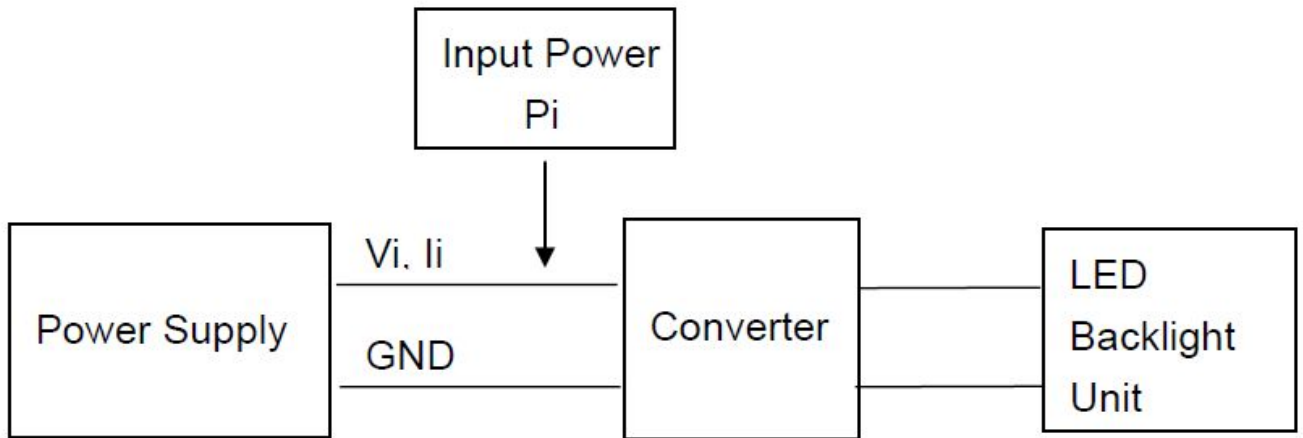

### 7.3 BLOCK DIAGRAM

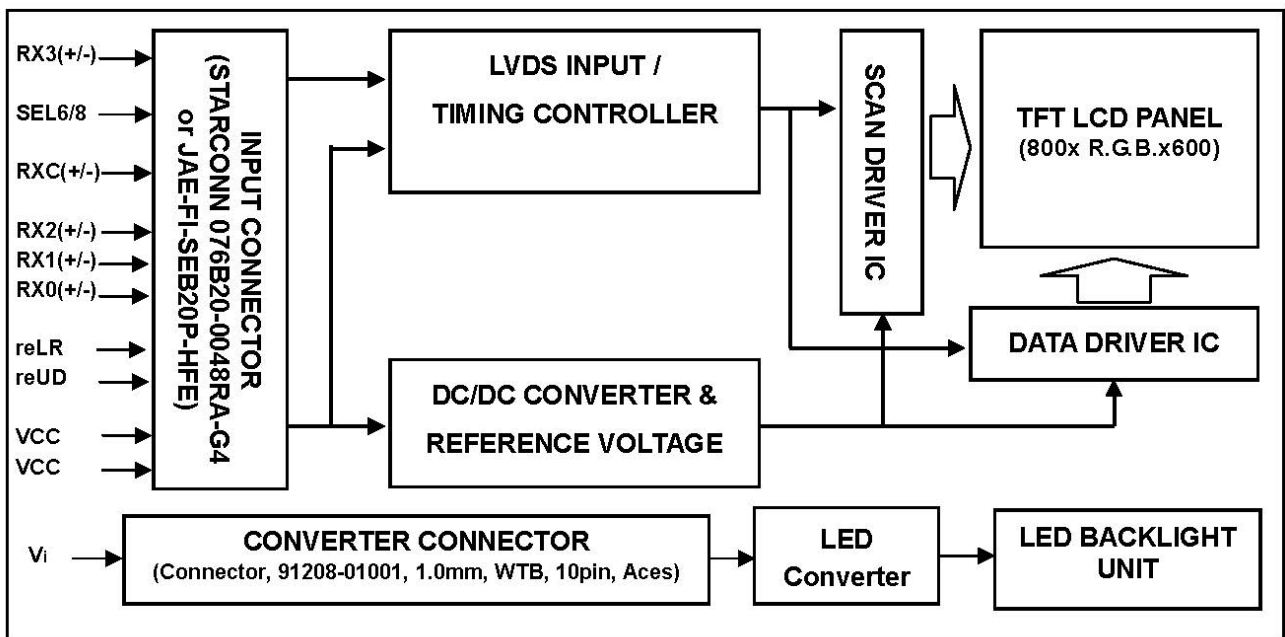

## 8. Timing Chart

### 8.1 INPUT SIGNAL TIMING SPECIFICATIONS

The input signal timing specifications are shown as the following table and timing diagram.

Signal	Item	Symbol	Min	Typ	Max	Unit	Note
DCLK	Frequency	Fc	34	40	48.3		
Horizontal Active Display Term	Display	Thd	-	800	-	Tc	-
	Blank	Thb	-	256	-	Tc	
	Total	Th	960	1056	1150	Tc	Th=Thd+Thb
Vertical Active Display Term	Display	Tvd	-	600	-	Th	
	Blank	Tvb	-	28	-	Th	
	Total	Tv	610	628	800	Th	Tv=Tvd+Tvb

Note (1) Since this assembly is operated in DE only mode, Hsync and Vsync input signals should be set to low logic level. Otherwise, this assembly would operate abnormally.

(2) Frame rate is 60Hz.

INPUT SIGNAL TIMING DIAGRAM

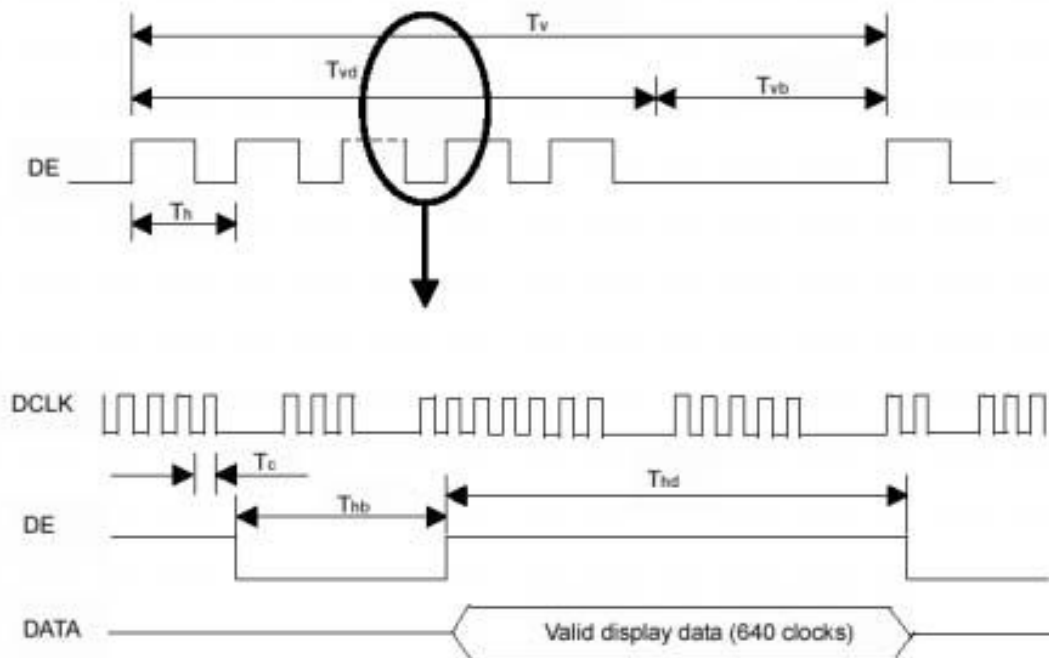

### 8.2 POWER ON/OFF SEQUENCE

To prevent a latch-up or DC operation of LCD assembly, the power on/off sequence should be as the diagram below.

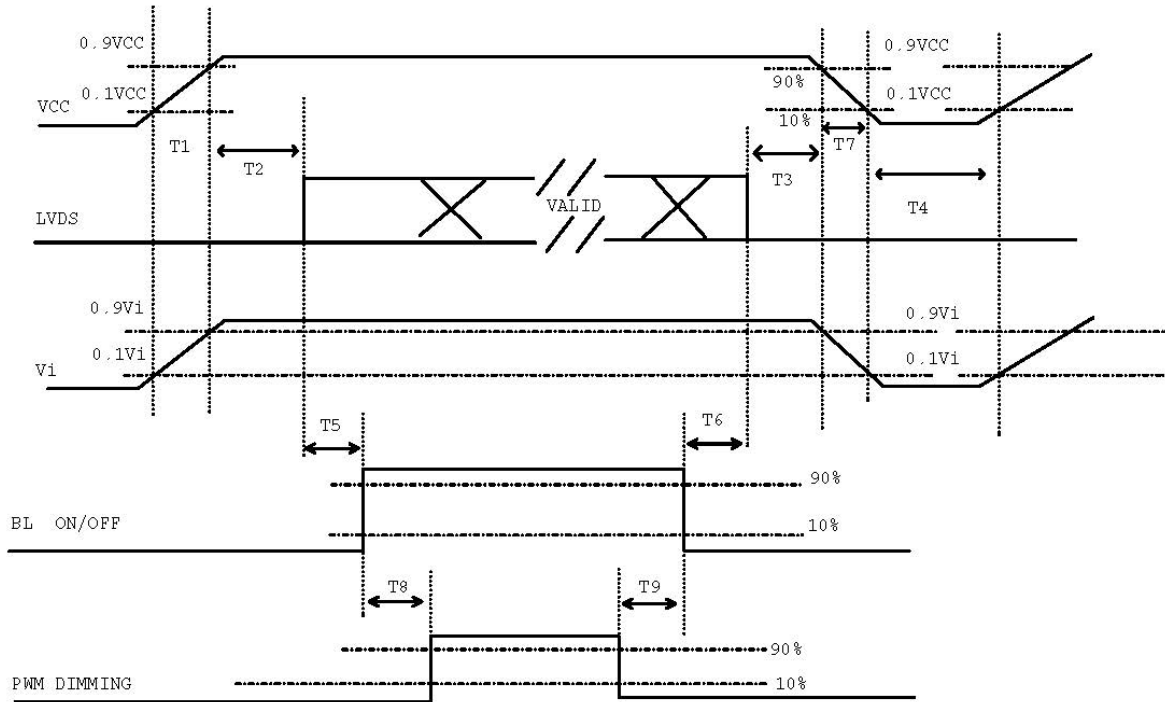

Power ON/OFF sequence

Note (1) Please avoid floating state of interface signal at invalid period.

Note (2) When the interface signal is invalid, be sure to pull down the power supply of LCD VCC to 0 V.

Note (3) The Backlight converter power must be turned on after the power supply for the logic and the interface signal is valid. The Backlight converter power must be turned off before the power supply for the logic and the interface signal is invalid.

Parameter	Value			Unit
	MIN	TYP	MAX	
T1	0.5		10	ms
T2	0		50	ms
T3	0		50	ms
T4	500			ms
T5	200			ms
T6	200			ms
T7	5		300	ms
T8	10			ms
T9	10			ms

## 8.3 The input data format

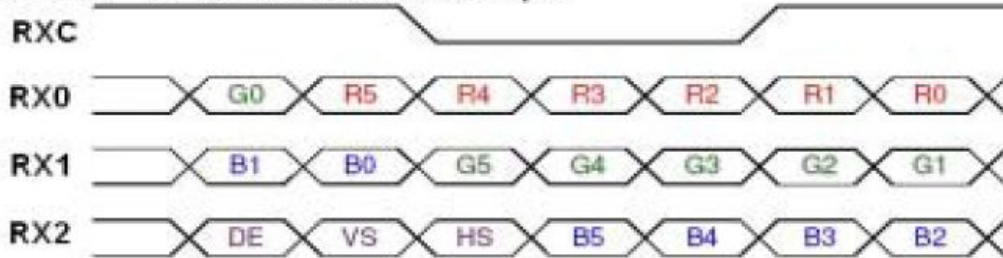
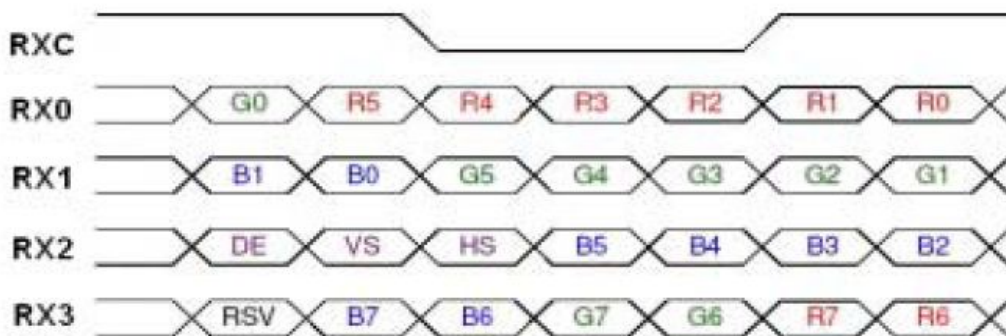
**SEL68 = "Low" or "NC" for 6 bits LVDS Input**

**SEL68 = "High" for 8 bits LVDS Input**

Note (1) R/G/B data 7: MSB, R/G/B data 0: LSB

Note (2) Please follow PSWG

Signal Name	Description	Remark
R7	Red Data 7 (MSB)	Red-pixel Data Each red pixel's brightness data consists of these 8 bits pixel data.
R6	Red Data 6	
R5	Red Data 5	
R4	Red Data 4	
R3	Red Data 3	
R2	Red Data 2	
R1	Red Data 1	
R0	Red Data 0 (LSB)	
G7	Green Data 7 (MSB)	Green-pixel Data Each green pixel's brightness data consists of these 8 bits pixel data.
G6	GreenData 6	
G5	GreenData 5	
G4	GreenData 4	
G3	GreenData 3	
G2	GreenData 2	
G1	GreenData 1	
G0	GreenData 0 (LSB)	
B7	Blue Data 7 (MSB)	Blue-pixel Data Each blue pixel's brightness data consists of these 8 bits pixel data.
B6	Blue Data 6	
B5	Blue Data 5	
B4	Blue Data 4	
B3	Blue Data 3	
B2	Blue Data 2	
B1	Blue Data 1	
B0	Blue Data 0 (LSB)	
RXCLKIN+ RXCLKIN-	LVDS Clock Input	
DE	Display Enable	
VS	Vertical Sync	
HS	Horizontal Sync	

Note (3) Output signals from any system shall be low or Hi-Z state when VCC is off.

## 8.4 Scanning Direction

The following figures show the image see from the front view. The arrow indicates the direction of scan.

Fig.1 Normal Scan



Fig.2 Reverse Scan

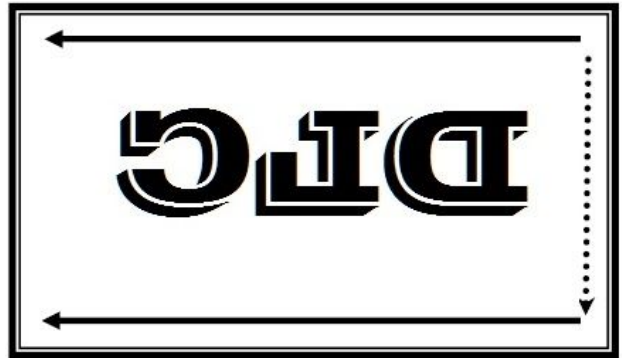

Fig.3 Reverse Scan

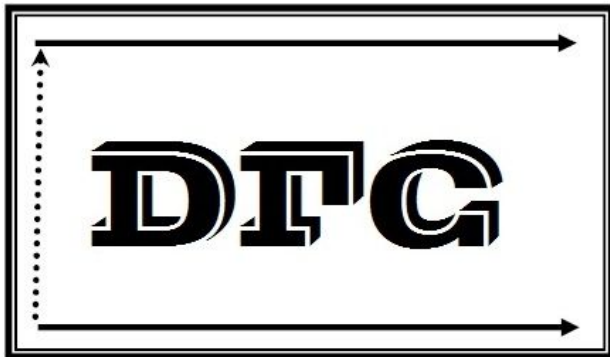

Fig.4 Reverse Scan

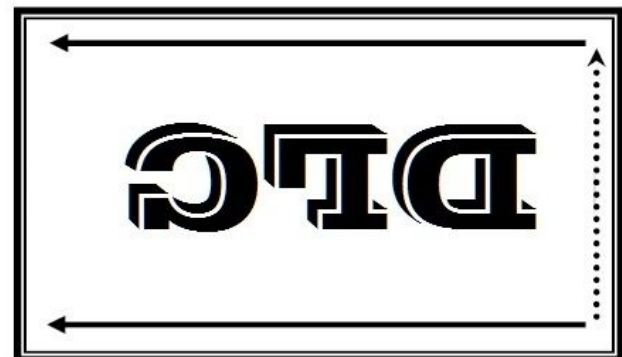

Fig. 1 Normal scan ( pin 17, reLR = Low or NC, pin 18, reUD = Low or NC )

Fig. 2 Reverse scan ( pin 17, reLR = High, pin 18, reUD = Low or NC )

Fig. 3 Reverse scan ( pin 17, reLR = Low or NC, pin 18, reUD = High )

Fig. 4 Reverse scan ( pin 17, reLR = High, pin 18, reUD = High )

9. Optical Specification

Ta=25°C

Item	Symbol	Condition	Min	Typ.	Max.	Unit	Remark
Contrast Ratio	CR	$\theta=0^\circ$	1200	1500	-		Note1 Note2
Response Time	Tr	25°C	-	13	18	ms	Note1
	Tf		-	12	17		Note3
View Angles	$\theta T$	$CR \geq 10$	80	89	-	Degree	Note 4
	$\theta B$		80	89	-		
	$\theta L$		80	89	-		
	$\theta R$		80	89	-		
Chromaticity	White	x	Brightness is on	Typ - 0.05	0.313	Typ +0.05	Note5, Note1
		y			0.329		
	Red	x			0.600		
		y			0.353		
	Green	x			0.348		
		y			0.568		
	Blue	x			0.150		
		y			0.097		
Center Luminance of White	L		400	450	-	cd/m <sup>2</sup>	Note1 Note6

Note 1: Definition of optical measurement system.

Temperature = 25°C (±3°C)

LED back-light: ON, Environment brightness < 150 lx

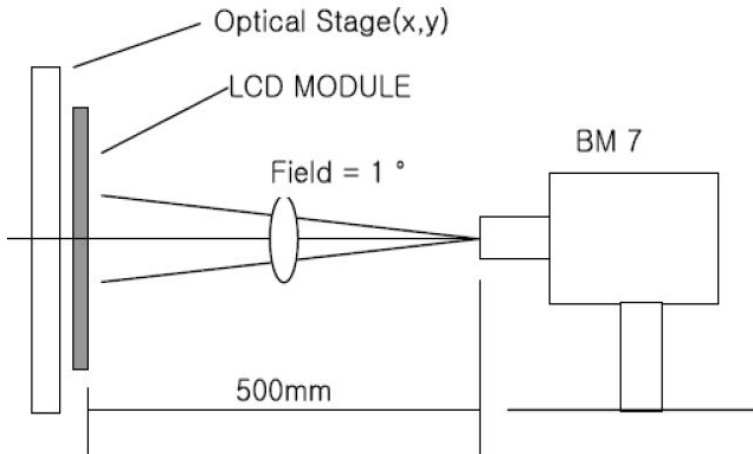

Note 2: Contrast ratio is defined as follow:

$$\text{Contrast Ratio} = \frac{\text{Surface Luminance with all white pixels}}{\text{Surface Luminance with all black pixels}}$$

Note 3: Response time is defined as follow:

Response time is the time required for the display to transition from black to white (Rise Time, Tr) and from white to black(Decay Time, Tf).

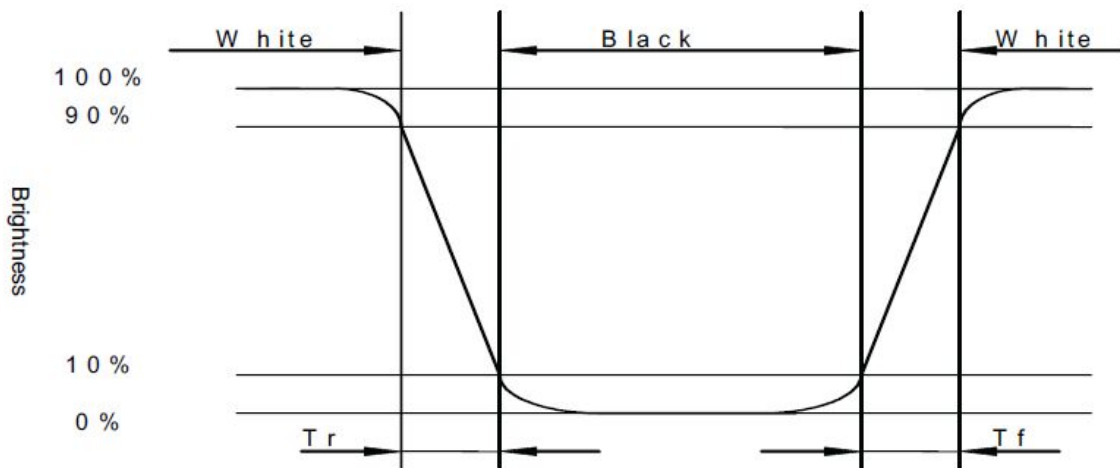

Note 4: Viewing angle range is defined as follow:

Viewing angle is measured at the center point of the LCD.

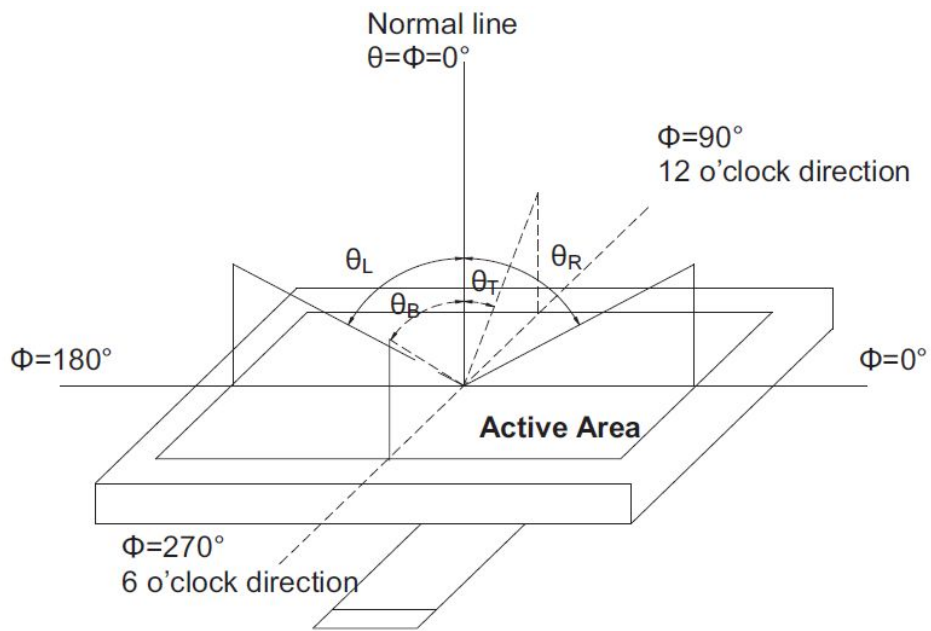

Note 5: Color chromaticity is defined as follow: (CIE1931)

Color coordinates measured at center point of LCD.

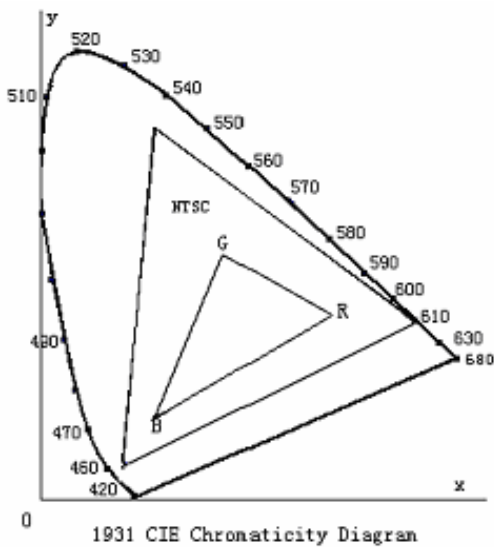

$$S = \frac{\text{area of RGB triangle}}{\text{area of NTSC triangle}} \times 100\%$$

Note 6: Definition of Luminance of White, Lc:

Measure the luminance of gray level 63 (255) at center point

### 10. Environmental / Reliability Tests

No	Test Item	Condition	Judgment criteria
1	High Temp Operation	Ts=+85°C, 240hrs	Per table in below
2	Low Temp Operation	Ta=-30°C, 240hrs	Per table in below
3	High Temp Storage	Ta=+85°C, 240hrs	Per table in below
4	Low Temp Storage	Ta=-30°C, 240hrs	Per table in below
5	High Temp & High Humidity Storage	Ta=+60°C, 90% RH 240 hours	Per table in below (polarizer discoloration is excluded)
6	Thermal Shock (Non-operation)	-30°C, 0.5hour ← → 85°C, 0.5hour; 1hour/cycle, 100cycles	Per table in below
7	ESD (Operation)	C=150pF, R=330Ω, 5points/panel Air:±8KV, 5times; Contact:±4KV, 5 times;	Per table in below
8	Vibration (Non-operation)	1.5G, 10 ~ 300 Hz, 10min/cycle, 3 cycles each X, Y, Z	Per table in below
9	Shock (Non-operation)	200G, 2ms, half sine wave, 1 time for ± X, ± Y, ± Z.	Per table in below
10	Package Drop Test	Height:60 cm, 1 corner, 3 edges, 6 surfaces	Per table in below

INSPECTION	CRITERION(after test)
Appearance	No Crack on the FPC, on the LCD Panel
Alignment of LCD Panel	No Bubbles in the LCD Panel No other Defects of Alignment in Active area
Electrical current	Within device specifications
Function / Display	No Broken Circuit, No Short Circuit or No Black line No Other Defects of Display

## 11. Precautions for Use of LCD Modules

### 11.1 Safety

The liquid crystal in the LCD is poisonous. Do not put it in your mouth. If the liquid crystal touches your skin or clothes, wash it off immediately using soap and water.

### 11.2 Handling

- A. The LCD and touch panel is made of plate glass. Do not subject the panel to mechanical shock or to excessive force on its surface.
- B. Do not handle the product by holding the flexible pattern portion in order to assure the reliability
- C. Transparency is an important factor for the touch panel. Please wear clear finger sacks, gloves and mask to protect the touch panel from finger print or stain and also hold the portion outside the view area when handling the touch panel.
- D. Provide a space so that the panel does not come into contact with other components.
- E. To protect the product from external force, put a covering lens (acrylic board or similar board) and keep an appropriate gap between them.
- F. Transparent electrodes may be disconnected if the panel is used under environmental conditions where dew condensation occurs.
- G. Property of semiconductor devices may be affected when they are exposed to light, possibly resulting in IC malfunctions.
- H. To prevent such IC malfunctions, your design and mounting layout shall be done in the way that the IC is not exposed to light in actual use.

### 11.3 Static Electricity

- A. Ground soldering iron tips, tools and testers when they are in operation.
- B. Ground your body when handling the products.
- C. Power on the LCD module before applying the voltage to the input terminals.
- D. Do not apply voltage which exceeds the absolute maximum rating.
- E. Store the products in an anti-electrostatic bag or container.

### 11.4 Storage

- A. Store the products in a dark place at  $+25^{\circ}\text{C} \pm 10^{\circ}\text{C}$  with low humidity (40% RH to 60% RH). Don't expose to sunlight or fluorescent light.
- B. Storage in a clean environment, free from dust, active gas, and solvent.

### 11.5 Cleaning

- A. Do not wipe the touch panel with dry cloth, as it may cause scratch.
- B. Wipe off the stain on the product by using soft cloth moistened with ethanol. Do not allow ethanol to get in between the upper film and the bottom glass. It may cause peeling issue or defective operation. Do not use any organic solvent or detergent other than ethanol.

### 11.6 Cautions for installing and assembling

Bezel edge must be positioned in the area between the Active area and View area. The bezel may press the touch screen and cause activation if the edge touches the active area. A gap of approximately 0.5mm is needed between the bezel and the top electrode. It may cause unexpected activation if the gap is too narrow. There is a tolerance of 0.2 to 0.3mm for the outside dimensions of the touch panel and tail. A gap must be made to absorb the tolerance in the case and connector.

