

TFT Module Specification

MODEL: 13-080SMTBIAA0-S

< ◇ > PRELIMINARY SPECIFICATION

< ◆ > APPROVAL SPECIFICATION

CUSTOMER
APPROVED BY
DATE:

DESIGNED	CHECKED	APPROVED
		 <p>PM 2015.10.16 呂家祥</p>

DigiWise International Corporation
8F., No. 4, Ln 83, Sec 1, Guang Fu Rd., Sanchong Dist., 24158,
New Taipei City, Taiwan (ROC)

TEL : +886-2-29992866

FAX : +886-2-29990900



RECORD OF REVISION

Version	Revised Date	Page	Content
V1.0	2015/10/16	--	First Issued

TABLE OF CONTENTS

No.	Content	Page
	TFT Module Specification	1
	TABLE OF CONTENTS	3
1.	GENERAL DESCRIPTION	4
2.	MECHANICAL SPECIFICATION	5
3.	PIN DESCRIPTION	6
4.	ABSOLUTE MAXIMUM RATINGS	8
5.	BLOCK DIAGRAM	9
6.	RELATIONSHIP BETWEEN DISPLAYED COLOR AND INPUT	10
7.	ELECTRICAL CHARACTERISTICS	11
8.	PROJECTED CAPACITIVE TOUCH PANEL	15
9.	OPTICAL CHARACTERISTICS	17
10.	RELIABILITY	20
11.	PRECAUTION RELATING PRODUCT HANDLING	25

1. GENERAL DESCRIPTION

1.1 Description

The specifications is model 13-080SMTBIAA0-S is a color active matrix thin film transistor (TFT) liquid crystal display (LCD) that uses amorphous silicon TFT as a switching device. This model is composed of a TFT LCD panel, a driving circuit, a back light system and projected capacitive touch panel. This TFT LCD has an 8.0 (4:3) inch diagonally measured active display area with SVGA (800 horizontal by 600 vertical pixels) resolution.

1.2 Features:

No.	Item	Specification	Unit
1	Panel Size	8.0"	Inch
2	Number of Pixels	800 (W) x RGB x 600 (H)	Pixels
3	Active Area	162 (W) × 121.5 (H)	mm
4	Pixel Pitch	0.2025 (W) x 0.2025 (H)	mm
5	Outline Dimension	183 (W) × 141 (H) × 8.5 (T)	mm
6	Number of Colors	262K	- -
7	Display Mode	TN / Normally White / Transmissive	- -
8	View Direction	6 o'clock(Gray Inversion)	
9	Display Format	RGB vertical stripe	- -
10	Surface Treatment	Clear (7H)	- -
11	Contrast Ratio	500 (Typ.)	- -
12	Luminance (cd/m ²)	420 (Typ.)	cd/m ²
13	Interface	RGB 18bit Interface	- -
14	Backlight	White LED	- -
15	Operation Temperature	-20 ~ 70	°C
16	Storage Temperature	-30 ~ 80	°C
17	Weight	TBD	g

2. MECHANICAL SPECIFICATION

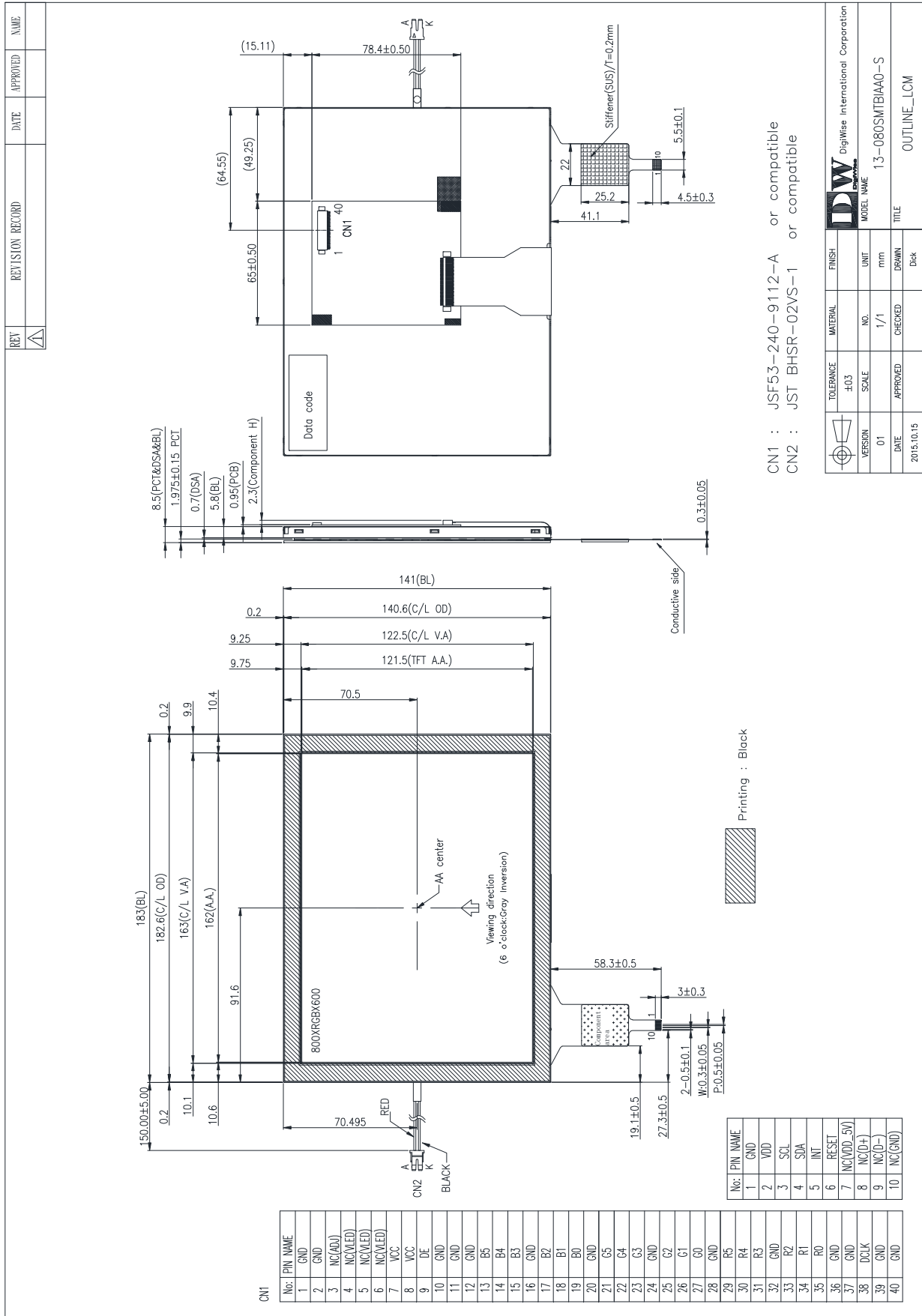

3. PIN DESCRIPTION

3.1 TFT LCD Module

Pin No.	Symbol	I/O	Function	Remark
1	GND	P	Ground	
2	GND	P	Ground	
3	NC	-	No Connect	
4	NC	-	No Connect	
5	NC	-	No Connect	
6	NC	-	No Connect	
7	VCC	P	Power Supply Logic voltage	
8	VCC	P	Power Supply Logic voltage	
9	DE	I	Data Enable Timing Signal	
10	GND	P	Ground	
11	GND	P	Ground	
12	GND	P	Ground	
13	B5	I	Blue data signal (MSB)	
14	B4	I	Blue data signal	
15	B3	I	Blue data signal	
16	GND	P	Ground	
17	B2	I	Blue data signal	
18	B1	I	Blue data signal	
19	B0	I	Blue data signal (LSB)	
20	GND	P	Ground	
21	G5	I	Green data signal (MSB)	
22	G4	I	Green data signal	
23	G3	I	Green data signal	
24	GND	P	Ground	
25	G2	I	Green data signal	
26	G1	I	Green data signal	
27	G0	I	Green data signal (LSB)	
28	GND	P	Ground	
29	R5	I	Red data signal (MSB)	
30	R4	I	Red data signal	
31	R3	I	Red data signal	
32	GND	P	Ground	
33	R2	I	Red data signal	
34	R1	I	Red data signal	
35	R0	I	Red data signal (LSB)	
36	GND	P	Ground	
37	GND	P	Ground	

38	DCLK	I	Data Clock	
39	GND	P	Ground	
40	GND	P	Ground	

NOTE:

1. NC Pin must be floating

3.2 Backlight Unit

Pin No.	Symbol	Function	Remark
1	LEDA	Power Supply for LED backlight	RED
2	LEDK	GND for LED backlight	BLACK

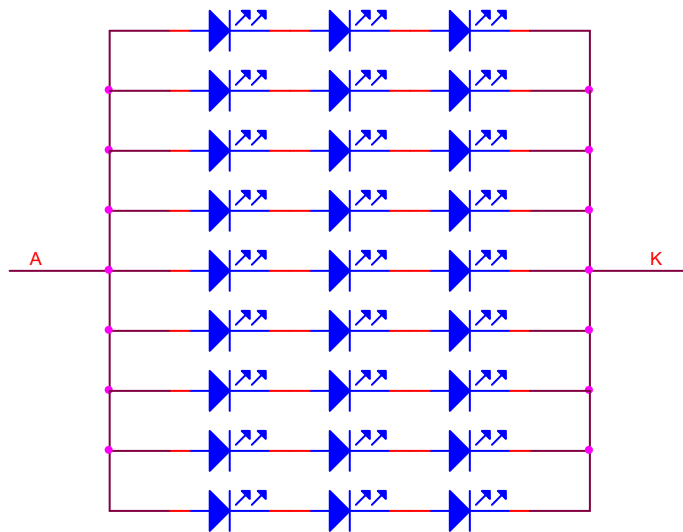

4. ABSOLUTE MAXIMUM RATINGS

4.1 Electrical Absolute Rating

4.1.1 TFT LCD Module

Item	Symbol	Values		Unit	Note
		Min	Max.		
Power supply voltage	VDD	-0.3	4.0	V	

4.1.2 Environment Absolute Rating

Item	Symbol	Values			Unit	Note
		Min	Typ	Max.		
Operating Temperature	Topa	-20		70	°C	Ambient temperature
Storage Temperature	Tstg	-30		80	°C	

5. BLOCK DIAGRAM

5.1 TFT LCD Module

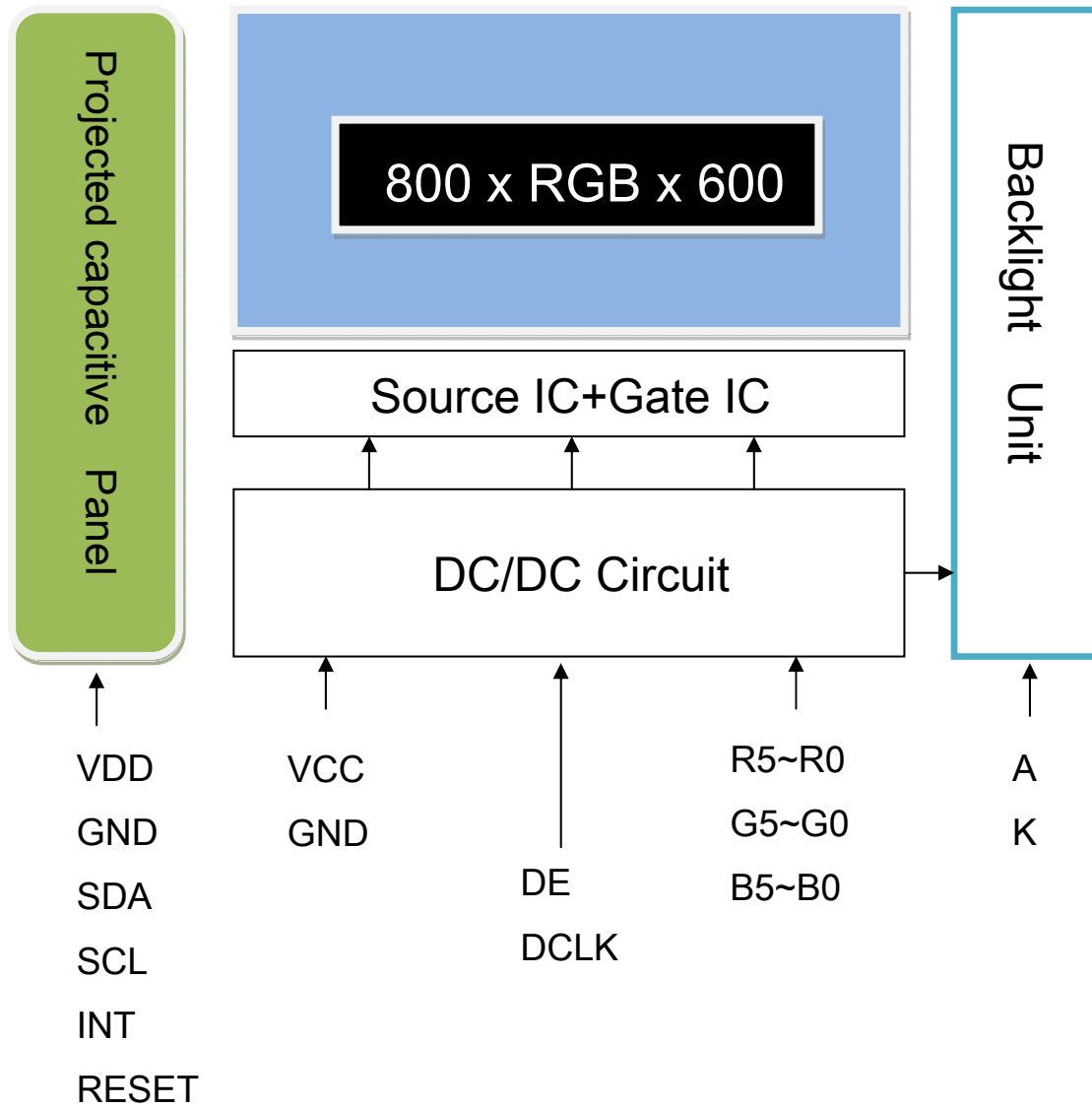

6. Relationship Between Displayed Color and Input

6.1 6 bit

	Color & Gray Scale	Data Signal																	
		R5	R4	R3	R2	R1	R0	G5	G4	G3	G2	G1	G0	B5	B4	B3	B2	B1	B0
Basic Color	Black	0	0	0	0	0	0	0	0	0	0	0	0	0	0	0	0	0	0
	Red	1	1	1	1	1	1	0	0	0	0	0	0	0	0	0	0	0	0
	Green	0	0	0	0	0	0	1	1	1	1	1	1	0	0	0	0	0	0
	Blue	0	0	0	0	0	0	0	0	0	0	0	0	1	1	1	1	1	1
	Cyan	0	0	0	0	0	0	1	1	1	1	1	1	1	1	1	1	1	1
	Magenta	1	1	1	1	1	1	0	0	0	0	0	0	1	1	1	1	1	1
	Yellow	1	1	1	1	1	1	1	1	1	1	1	1	0	0	0	0	0	0
	White	1	1	1	1	1	1	1	1	1	1	1	1	1	1	1	1	1	1
Red	Black	0	0	0	0	0	0	0	0	0	0	0	0	0	0	0	0	0	0
	Red(1)	0	0	0	0	0	1	0	0	0	0	0	0	0	0	0	0	0	0
	Red(2)	0	0	0	0	1	0	0	0	0	0	0	0	0	0	0	0	0	0
	:	:	:	:	:	:	:	:	:	:	:	:	:	:	:	:	:	:	:
	Red(31)	0	1	1	1	1	1	0	0	0	0	0	0	0	0	0	0	0	0
	:	:	:	:	:	:	:	:	:	:	:	:	:	:	:	:	:	:	:
	Red(62)	1	1	1	1	1	0	0	0	0	0	0	0	0	0	0	0	0	0
Red(63)	1	1	1	1	1	1	0	0	0	0	0	0	0	0	0	0	0	0	
Green	Black	0	0	0	0	0	0	0	0	0	0	0	0	0	0	0	0	0	0
	Green(1)	0	0	0	0	0	0	0	0	0	0	0	1	0	0	0	0	0	0
	Green(2)	0	0	0	0	0	0	0	0	0	0	1	0	0	0	0	0	0	0
	:	:	:	:	:	:	:	:	:	:	:	:	:	:	:	:	:	:	:
	Green(31)	0	0	0	0	0	0	0	1	1	1	1	0	0	0	0	0	0	0
	:	:	:	:	:	:	:	:	:	:	:	:	:	:	:	:	:	:	:
	Green(62)	0	0	0	0	0	0	1	1	1	1	1	0	0	0	0	0	0	0
Green(63)	0	0	0	0	0	0	1	1	1	1	1	1	0	0	0	0	0	0	
Blue	Black	0	0	0	0	0	0	0	0	0	0	0	0	0	0	0	0	0	0
	Blue(1)	0	0	0	0	0	0	0	0	0	0	0	0	0	0	0	0	0	1
	Blue(2)	0	0	0	0	0	0	0	0	0	0	0	0	0	0	0	0	0	1
	:	:	:	:	:	:	:	:	:	:	:	:	:	:	:	:	:	:	:
	Blue(31)	0	0	0	0	0	0	0	0	0	0	0	0	0	1	1	1	1	1
	:	:	:	:	:	:	:	:	:	:	:	:	:	:	:	:	:	:	:
	Blue(62)	0	0	0	0	0	0	0	0	0	0	0	0	1	1	1	1	1	0
Blue(63)	0	0	0	0	0	0	0	0	0	0	0	0	1	1	1	1	1	1	

0 : Low level voltage, 1 :High level voltage

Each basic color can be displayed in 64 gray scales from 6 bit data signals. With the combination of total 18 bit data signals, the 262K-color display can be achieved on the screen.

7. ELECTRICAL CHARACTERISTICS

7.1 TFT LCD Module

Item	Symbol	Value			Unit	Note	
		Min.	Typ.	Max.			
Power supply voltage	VCC	3.0	3.3	3.6	V		
Input Voltage for logic	H Level	VIH	0.7xVCC	-	VCC	V	
	L Level	VIL	0	-	0.3xVCC	V	
Digital Current	ICC	-	(120)	(150)	mA	Note1	

Note 1: frame =60Hz , Ta=25°C , Display pattern : Black pattern



7.2 Backlight Unit

Item	Symbol	Value			Unit	Condition
		Min.	Typ.	Max.		
LED Voltage	VL	(9.0)	(9.9)	(10.5)	V	
LED Current	IF	-	180	-	mA	3S9P
Power Consumption	PBL	-	1.782	-	mW	
LED Life Time (25°C)	-	(40000)	-	-	hr	(1)

Note (1): The "LED life time" is defined as the module brightness decrease to 50% original brightness that the ambient temperature is 25°C 60% RH.

7.3 INTERFACE SPECIFICATIONS

7.3.1 AC Timing characteristics

Signal	Parameter	Symbol	Min.	Typ.	Max.	Unit.	Remark
HSYNC	HS setup time	T _{hst}	8	-	-	ns	
	HS hold time	T _{hhd}	8	-	-	ns	
VSYNC	VS setup time	T _{vst}	8	-	-	ns	
	VS hold time	T _{vhd}	8	-	-	ns	
Data	Data setup time	T _{dsu}	8	-	-	ns	
	Data hold time	T _{dhd}	8	-	-	ns	
DE	DEN setup time	T _{vpw}	8	-	-	ns	
	DEN hold time	T _{vb}	8	-	-	ns	

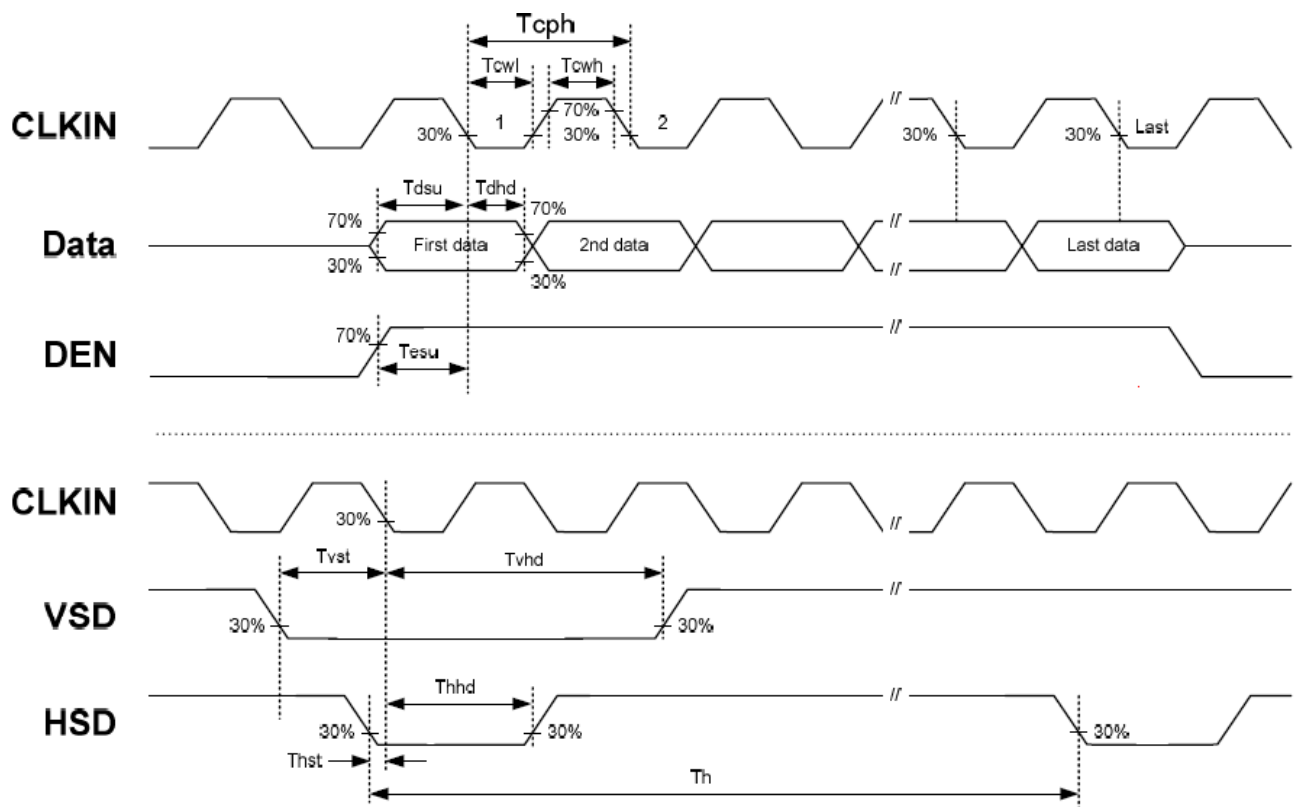

7.3.2 DE Mode Input Timing Table

Signal	Parameter	Symbol	Min.	Typ.	Max.	Unit.	Remark
DCLK	CLK frequency	Fclk	-	40	50	MHz	
	CLK period	Tcph	20	-	-	ns	
	CLK pulse duty	Tcwh	40	50	60	%	
HSYNC	Horizontal Line	Th	862	1056	1200	CLK	
	HS Display Area	Thd	-	800	-	CLK	
	HS Pulse Width	Thpw	1	-	40	CLK	
	HS Back Porch	Thb	-	46	-	CLK	
	HS Front Porch	Thfp	16	210	354	CLK	
VSYNC	VS Display Area	Tvd	-	600	-	th	
	VS Period Time	Tv	624	635	700	th	
	VS Pulse Width	Tvpw	1	-	20	th	
	VS Back Porch	Tvb	-	23	-	th	
	VS Front Porch	Tvfp	1	12	77	th	

Horizontal input timing

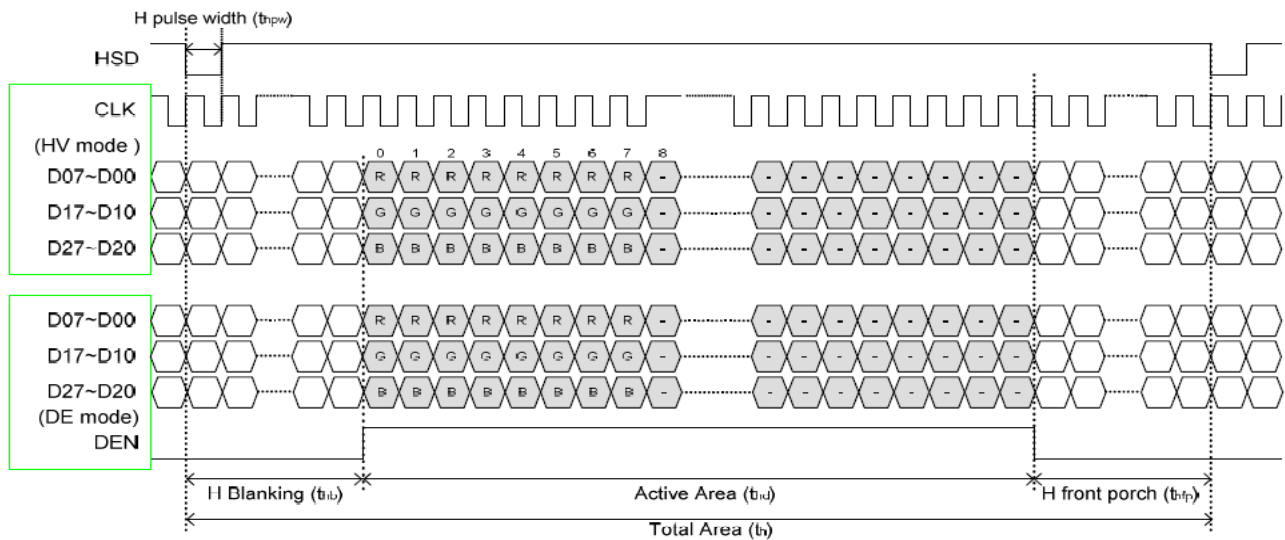

Vertical input timing

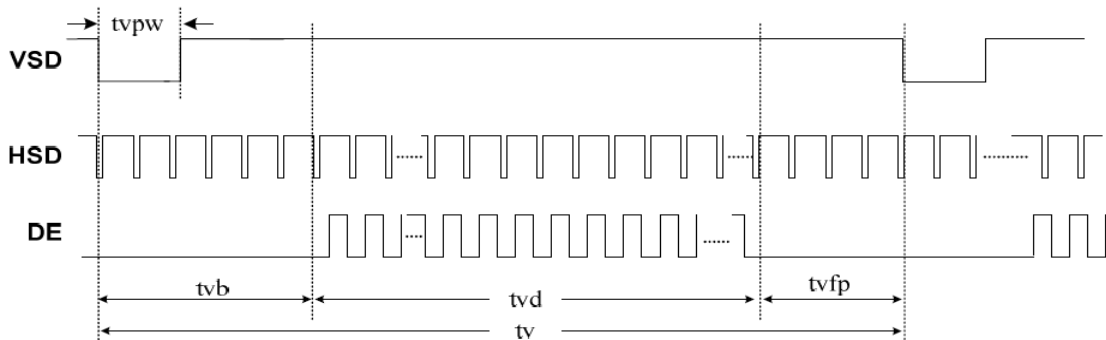

7.4 Power On / Off Sequence

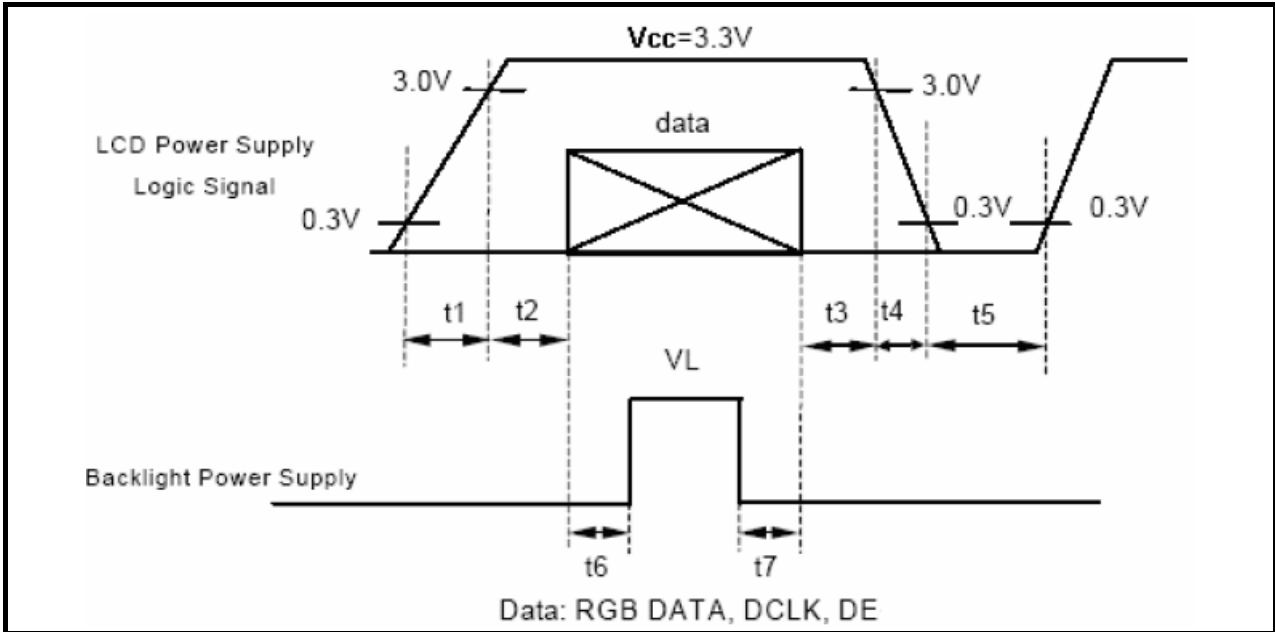

$t1 \leq 10\text{ms} : 1 \text{ sec} \leq t5$
 $50\text{ms} \leq t2 : 200\text{ms} \leq t6$
 $0 < t3 \leq 50\text{ms} : 200\text{ms} \leq t7$
 $0 < t4 \leq 10\text{ms}$

8. PROJECTED CAPACITIVE TOUCH PANEL

8.1 Main Feature

Item	Specification	Unit
Screen Size	8.0 inch	Diagonal
Type	Transparent Type Projected Capacitive	--
Input Mode	Human's Finger	--
Finger	5	--
Interface	I2C	--
Cover glass pencil-hardness	7H	--
Response time	25	ms
Driver IC	FT5826	

8.2 Pin Assignments and Definitions

Item	Name	I/O	Unit
1	GND	P	Power ground
2	VDD	P	Power; VCC =3.3V(typ.)
3	SCL	I	Serial Clock
4	SDA	I/O	Serial data access
5	/INT	O	Interrupt signal to inform the host processor that touch data is ready for read
6	RESET	I	External low signal reset the chip.
7	NC	-	NO connection
8	NC	-	NO connection
9	NC	-	NO connection
10	NC	-	NO connection

8.3 ELECTRICAL CHARACTERISTICS

Communication protocol: I2C

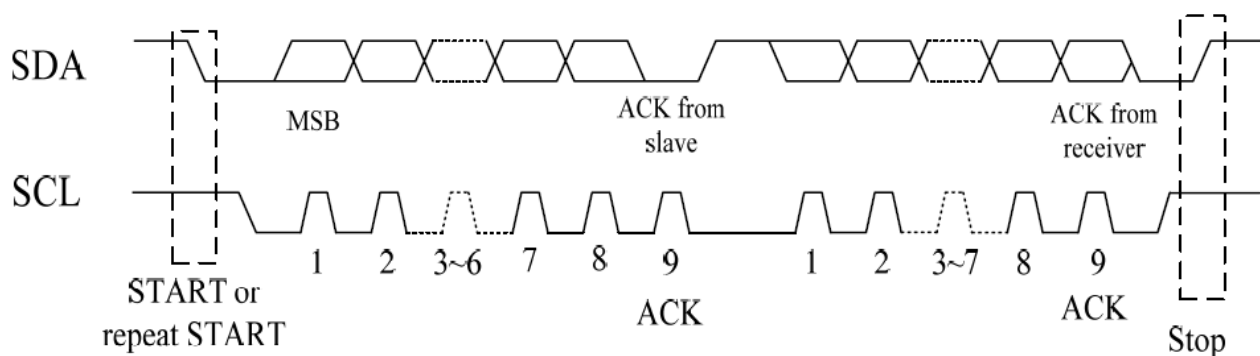

8.4 I2C Interface Protocol

8.4.1 Default I2C Address

The default I2C Address of FT5306 is 0x70 (7-bit address)

8.4.2 I2C master write, slave read

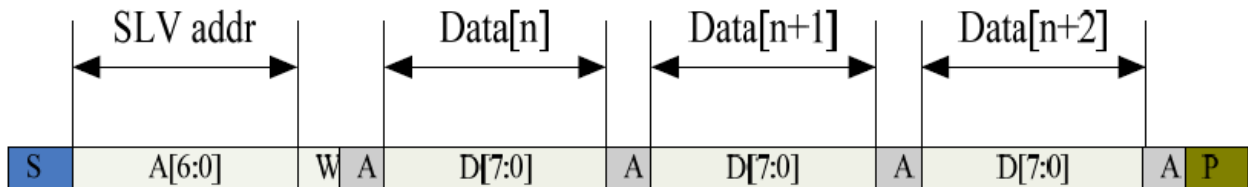

8.4.3 I2C master read, slave write

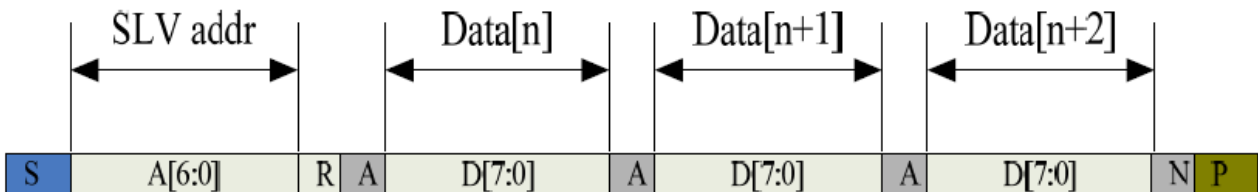

Mnemonics	Description
S	I2C Start or I2C Restart
A[6:0]	Slave address A[6:4]: 3'b011 A[3:0]: data bits are identical to those of I2CCON[7:4] register.
W	1'b0: Write
R	1'b1: Read
A(N)	ACK(NACK)
P	STOP: the indication of the end of a packet (if this bit is missing, S will indicate the end of the current packet and the beginning of the next packet)

9. OPTICAL CHARACTERISTICS

Item	Symbol	Condition	Min.	Typ.	Max.	Unit
Brightness	--	Note1, Note 3, ($\theta = 0^\circ$; Normal Viewing Angle)	330	420	--	cd/m ²
Uniformity	B-uni		70	75	-	%
Contrast Ratio	CR		400	500	--	--
Response Time	Tr		--	10	--	ms
	Tf	--	15	--	ms	
Color Chromaticity	White	Wx	0.260	0.310	0.360	--
		Wy	0.280	0.330	0.380	--
View angle	Horizontal	$\theta x+$	60	70	--	
		$\theta x-$	60	70	--	
	Vertical	$\theta Y+$	40	50	--	
		$\theta Y-$	60	75	--	

Note : The following optical specifications shall be measured in a darkroom or equivalent state(ambient luminance ≤ 1 lux, and at room temperature). The operation temperature is $25^\circ\text{C} \pm 2^\circ\text{C}$. The measurement method is shown in Note1.

Note1: The method of optical measurement:

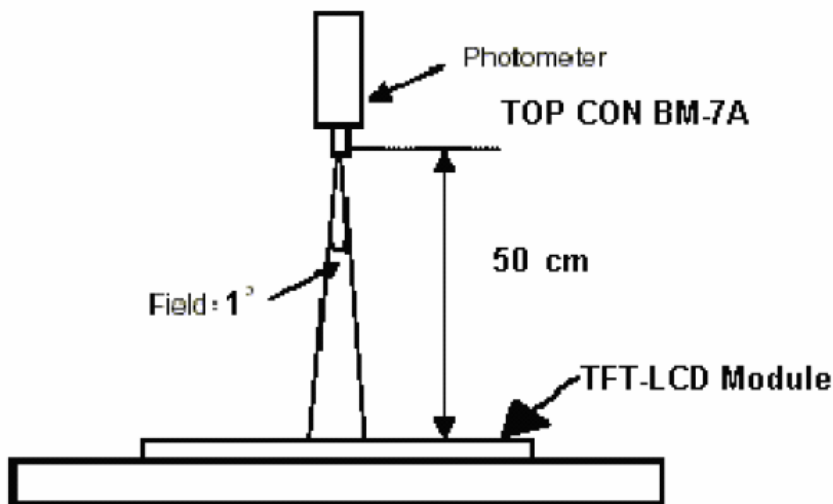

Note2: Measured at the center area of the panel and at the viewing angle of the $\theta x = \theta y = 0^\circ$

Note3: Definition of Contrast Ratio (CR):

CR = Luminance with all pixels in white state \div Luminance with all pixels in Black state

Note 4: Definition of Viewing Angle:

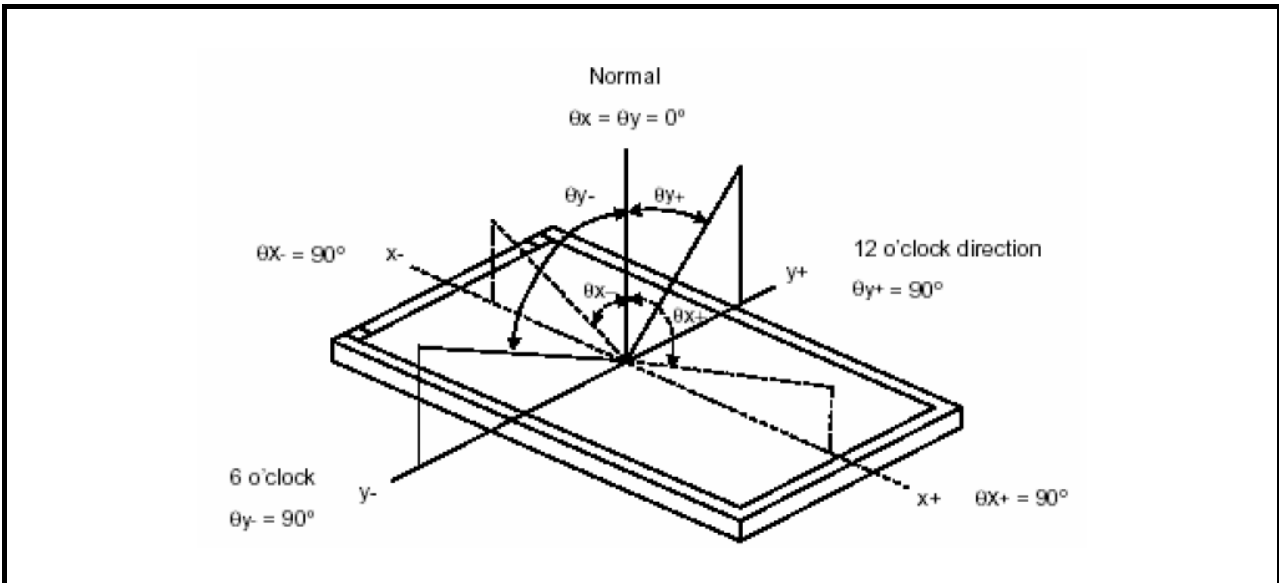

Note 5: Definition of Brightness Uniformity (B-uni):

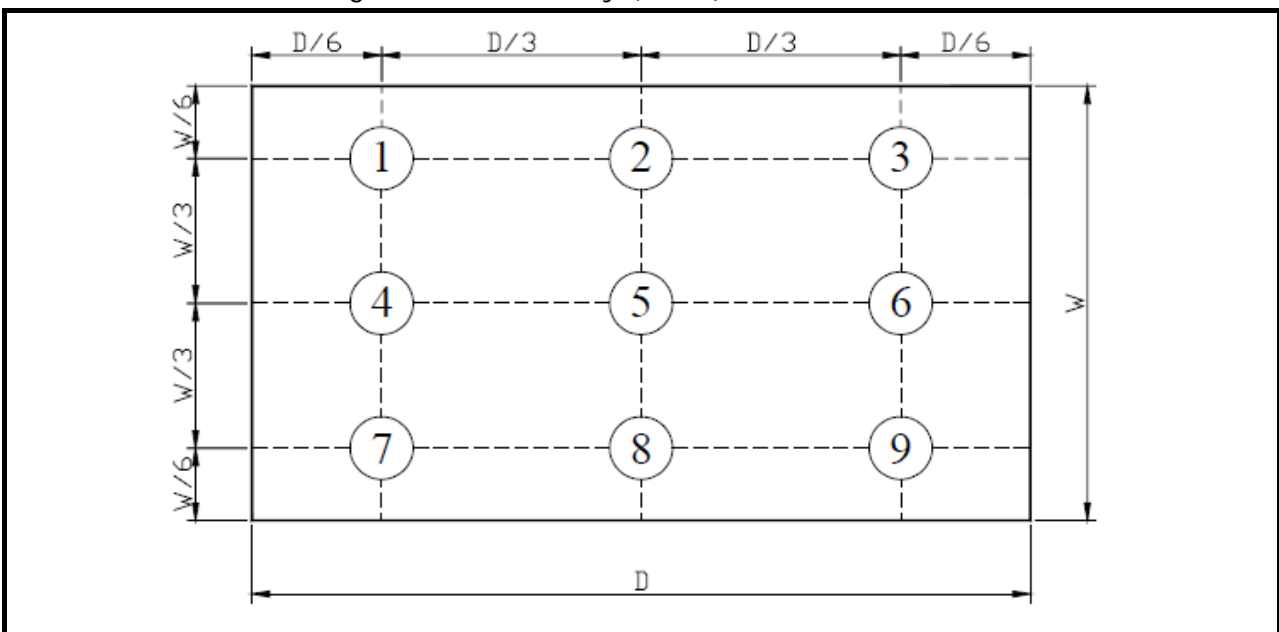

B-uni = (Minimum luminance of 9 points ÷ Maximum luminance of 9 points) X 100%

Note 6: Definition of Response Time:

The Response Time is set initially by defining the “Rising Time (T_r)” and the “Falling Time (T_f)” respectively. T_r and T_f are defined as following figure

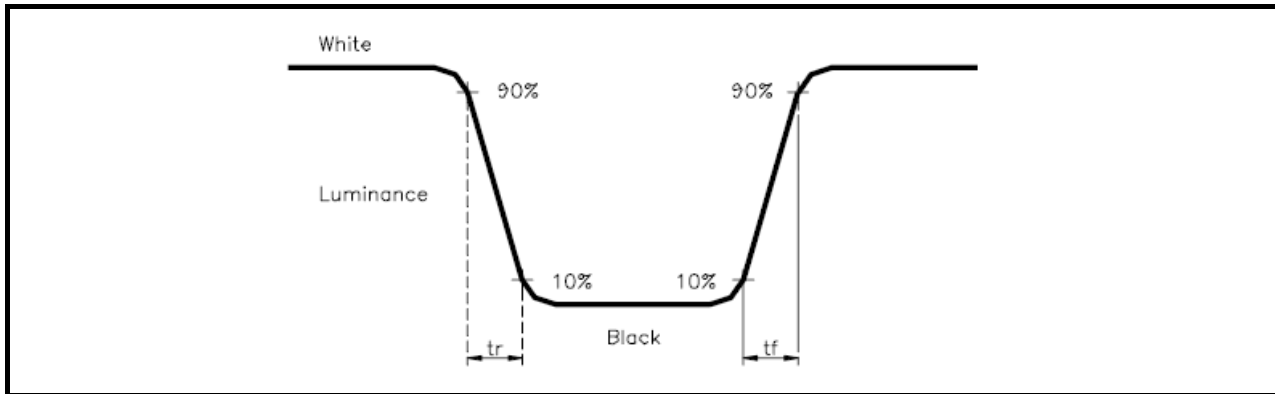

Note 7: Definition of Chromaticity:

The color coordinates (W_x, W_y), (R_x, R_y), (G_x, G_y), and (B_x, B_y) are obtained with all pixels in the viewing field at white, red, green, and blue states, respectively.

10. RELIABILITY

10.1 Test Condition

10.1.1 Temperature and Humidity(Ambient Temperature)

Temperature : 25 ± 5°C

Humidity : 65 ± 5%

10.1.2 Operation

Unless specified otherwise, test will be conducted under function state.

10.1.3 Container

Unless specified otherwise, vibration test will be conducted to the product itself without putting it in a container.

10.1.4 Test Frequency

In case of related to deterioration such as shock test. It will be conducted only once.

10.2 TESTS

No.	ITEM	CONDITION CRITERION
1	High Temperature Storage	80°C, 120 hrs
2	Low Temperature Storage	-30°C, 120 hrs
3	High Temperature Operating	70°C, 120 hrs
4	Low Temperature Operating	-20°C, 120 hrs
5	High Temperature/Humidity Non-Operating	60°C, 90%RH, 120 hrs
6	Temperature Shock Non-Operating	-30°C ←→ 80°C (0.5hr each), 25 cycles
7	Vibration Test Non-Operating	Frequency:0 ~ 55 Hz Amplitude:1.5 mm Sweep Time:11min Test Period:6 Cycles for each Direction of X,Y,Z
8	Electro-static Discharge	±2KV, Human Body Mode, 100pF/1500Ω

Note1: The test sample have recovery time for 24 hours at room temperature before the function check. In the standard conditions, there is no any touch panel function NG issue occurred.

10.3 JUDGMENT STANDARD

The judgment of the above test should be made as follow:

Pass: Normal display image with no obvious non-uniformity and no line defect. Partial transformation of the module parts should be ignored.

Fail: No display image, obvious non-uniformity, or line defects.

10.4 INCOMING INSPECTION STANDARDS

No.	Parameter	Criteria												
1	Operating	Display function: No Display malfunction (Major)												
		Contrast ratio (Black, White): Does not meet specified range in the spec. (Major) (Note:3)												
		Line Defect: No obvious Vertical and Horizontal line defect in bright, dark and colored. (Major) (Note:1)												
		Point Defect : Active area ≤ 5 dots (Minor) (Note:1)												
		<table border="1"> <thead> <tr> <th rowspan="2">Item</th> <th>Acceptable number</th> <th rowspan="2">Total</th> </tr> <tr> <th>Active Area</th> </tr> </thead> <tbody> <tr> <td>Bright</td> <td>2</td> <td rowspan="2">5</td> </tr> <tr> <td>Dark</td> <td>4</td> </tr> </tbody> </table>	Item	Acceptable number	Total	Active Area	Bright	2	5	Dark	4			
Item	Acceptable number	Total												
	Active Area													
Bright	2	5												
Dark	4													
2	External Inspection (non-operating)	Non-uniformity: Visible through 5%ND filter. (Minor)												
		Foreign material in Black or White spots shape ($W > 1/4L$)												
		<table border="1"> <thead> <tr> <th>Zone Dimension</th> <th>Acceptable number</th> <th rowspan="3">Class Of Defects</th> <th rowspan="3">AQL Level</th> </tr> </thead> <tbody> <tr> <td>$D > 0.5$</td> <td>0</td> </tr> <tr> <td>$0.3 < D \leq 0.5$</td> <td>5</td> </tr> <tr> <td>$D \leq 0.3$</td> <td>*</td> <td>Minor</td> <td>1.5</td> </tr> </tbody> </table> <p>$D = (\text{Long} + \text{Short}) / 2$ * : Disregard</p>	Zone Dimension	Acceptable number	Class Of Defects	AQL Level	$D > 0.5$	0	$0.3 < D \leq 0.5$	5	$D \leq 0.3$	*	Minor	1.5
		Zone Dimension	Acceptable number	Class Of Defects			AQL Level							
		$D > 0.5$	0											
$0.3 < D \leq 0.5$	5													
$D \leq 0.3$	*	Minor	1.5											
Foreign Material in Line or spiral shape ($W \leq 1/4L$) (Note: 4)														
<table border="1"> <thead> <tr> <th>Zone L (mm) \ W(mm)</th> <th>Acceptable number</th> <th rowspan="3">Class Of Defects</th> <th rowspan="3">AQL Level</th> </tr> </thead> <tbody> <tr> <td>$L > 5$ $W > 0.1$</td> <td>0</td> </tr> <tr> <td>$0.5 < L \leq 5$ $0.03 < W \leq 0.1$</td> <td>5</td> </tr> <tr> <td>$L \leq 0.5$ $W \leq 0.03$</td> <td>*</td> <td>Minor</td> <td>1.5</td> </tr> </tbody> </table> <p>L : Length W : Width * : Disregard</p>	Zone L (mm) \ W(mm)	Acceptable number	Class Of Defects	AQL Level	$L > 5$ $W > 0.1$	0	$0.5 < L \leq 5$ $0.03 < W \leq 0.1$	5	$L \leq 0.5$ $W \leq 0.03$	*	Minor	1.5		
Zone L (mm) \ W(mm)	Acceptable number	Class Of Defects			AQL Level									
$L > 5$ $W > 0.1$	0													
$0.5 < L \leq 5$ $0.03 < W \leq 0.1$	5													
$L \leq 0.5$ $W \leq 0.03$	*	Minor	1.5											
2	External Inspection (non-operating)	Dimension: Outline (Major)												
		Bezel appearance: uneven (Minor)												
		Scratch on the polarize: (Note:2)												
		<table border="1"> <thead> <tr> <th>Zone L (mm) \ W(mm)</th> <th>Acceptable number</th> <th rowspan="3">Class Of Defects</th> <th rowspan="3">AQL Level</th> </tr> </thead> <tbody> <tr> <td>-- $W > 0.1$</td> <td>0</td> </tr> <tr> <td>$L \leq 3$ $W \leq 0.1$</td> <td>3</td> </tr> </tbody> </table> <p>L : Length W : Width * : Disregard</p>	Zone L (mm) \ W(mm)	Acceptable number	Class Of Defects	AQL Level	-- $W > 0.1$	0	$L \leq 3$ $W \leq 0.1$	3				
		Zone L (mm) \ W(mm)	Acceptable number	Class Of Defects			AQL Level							
-- $W > 0.1$	0													
$L \leq 3$ $W \leq 0.1$	3													
Dent or bubble on the polarize (Note:2)														
<table border="1"> <thead> <tr> <th>Zone Dimension</th> <th>Acceptable number</th> <th rowspan="3">Class Of Defects</th> <th rowspan="3">AQL Level</th> </tr> </thead> <tbody> <tr> <td>$D \leq 0.3$</td> <td>*</td> </tr> <tr> <td>$D \leq 0.5$</td> <td>3</td> </tr> </tbody> </table> <p>$D = (\text{Long} + \text{Short}) / 2$ * : Disregard</p>	Zone Dimension	Acceptable number	Class Of Defects	AQL Level	$D \leq 0.3$	*	$D \leq 0.5$	3						
Zone Dimension	Acceptable number	Class Of Defects			AQL Level									
$D \leq 0.3$	*													
$D \leq 0.5$	3													

Class of defects			Definition
	Major	AQL 0.65%	It is a defect that is likely to result in failure or to reduce materially the usability of the product for the intended function.
Minor	AQL 1.5%	It is a defect that will not result in functioning problem with deviation classified.	

Note1:

(a) Bright point defect is defined as point defect of R,G,B with area >1/2 pixel respectively

(b) Dark point defect is defined as visible in full white pattern.

(c) Definition of distribution of point defect is as follows:

- minimum separation between dark point defects should be larger than 5mm.
- minimum separation between bright point defects should be larger than 5mm.

(d) Definition of joined bright point defect and joined dark point defect are as follows:

- Two or more joined bright point defects must be nil.
- Three joined dark point defects must be nil.
- Coupling of one dark and one bright point in junction is counted as one dark and bright spot with 1 pair maximum.
- Two Joined dark point is counted as two dark points with 2 pair maximum.

Note2: The external inspection should be conducted at the distance 30 ± 5 cm between the eyes of inspector and the panel.

Note3: Luminance measurement for contrast ratio is at the distance 50 ± 5 cm between the detective head and the panel with ambient luminance less than 1 lux. Contrast ratio is obtained at optimum view angle.

Note4: W-Width in mm , L-length of Max.(L1,L2) in mm.

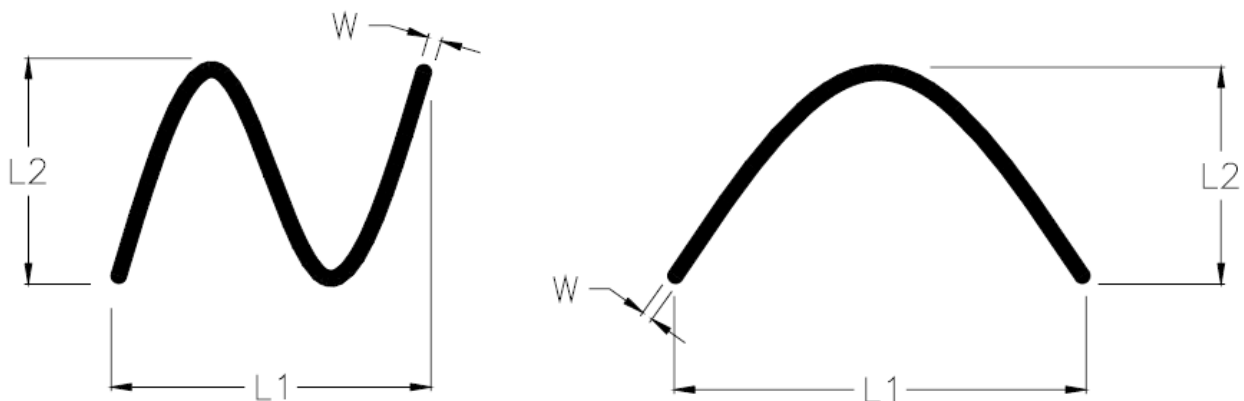

10.5 Sampling Condition

Unless otherwise agree in written, the sampling inspection shall be applied to the incoming inspection of customer.

Lot size: Quantity of shipment lot per model.

Sampling type: normal inspection, single sampling

Sampling table: MIL-STD-105E

Inspection level: Level II

10.6 Inspection conditions

The LCD shall be inspected under 40W white fluorescent light.

$\theta \leq 45^\circ$ inspection under non-operating condition.

$\theta \leq 5^\circ$ inspection under operating condition

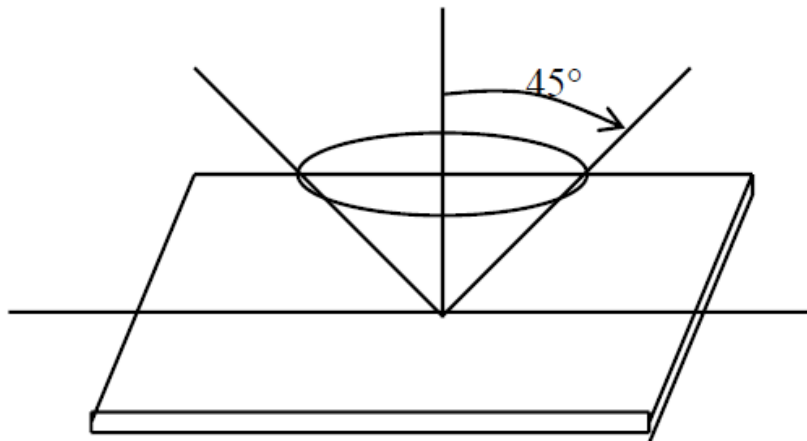

11. PRECAUTION RELATING PRODUCT HANDLING

11.1 SAFETY

11.1.1 If the LCD panel breaks , be careful not to get the liquid crystal to touch your skin.

11.1.2 If the liquid crystal touches your skin or clothes , please wash it off immediately by using soap and water.

11.2 HANDLING

11.2.1 Avoid any strong mechanical shock which can break the glass.

11.2.2 Avoid static electricity which can damage the CMOS LSI—When working with the module, be sure to ground your body and any electrical equipment you may be using.

11.2.3 Do not remove the panel or frame from the module.

11.2.4 The polarizing plate of the display is very fragile. So , please handle it very carefully, Do not touch, push or rub the exposed polarizing with anything harder than an HB pencil lead (glass , tweezers , etc.)

11.2.5 Do not wipe the polarizing plate with a dry cloth, as it may easily scratch the surface of plate.

11.2.6 Do not touch the display area with bare hands , this will stain the display area.

11.2.7 Do not use ketonics solvent & aromatic solvent. Use with a soft cloth soaked with a cleaning naphtha solvent.

11.2.8 To control temperature and time of soldering is $280 \pm 10^{\circ}\text{C}$ and 3-5 sec.

11.2.9 To avoid liquid (include organic solvent) stained on LCM.

11.3 STORAGE

11.3.1 Store the panel or module in a dark place where the temperature is $25^{\circ}\text{C} \pm 5^{\circ}\text{C}$ and the humidity is below 65% RH.

11.3.2 Do not place the module near organics solvents or corrosive gases.

11.3.3 Do not crush, shake, or jolt the module.