

TFT Module Specification

MODEL: 13-057VMTBIAB1-S

< ◇ > PRELIMINARY SPECIFICATION

< ◆ > APPROVAL SPECIFICATION

CUSTOMER
APPROVED BY
DATE:

DESIGNED	CHECKED	APPROVED
		 <p>PM 2015.05.26 呂家祥</p>

DigiWise International Corporation
8F., No. 4, Ln 83, Sec 1, Guang Fu Rd., Sanchong Dist., 24158,
New Taipei City, Taiwan (ROC)

TEL : +886-2-29992866

FAX : +886-2-29990900



RECORD OF REVISION

Version	Revised Date	Page	Content
V1.0	2015/05/25	--	First Issued

TABLE OF CONTENTS

No.	Content	Page
	TFT Module Specification	1
	TABLE OF CONTENTS	3
1.	GENERAL DESCRIPTION	4
2.	MECHANICAL SPECIFICATION	5
3.	PIN DESCRIPTION	6
4.	ABSOLUTE MAXIMUM RATINGS	8
5.	BLOCK DIAGRAM	9
6.	RELATIONSHIP BETWEEN DISPLAYED COLOR AND INPUT	10
7.	ELECTRICAL CHARACTERISTICS	11
8.	PROJECTED CAPACITIVE TOUCH PANEL	15
9.	OPTICAL CHARACTERISTICS	21
10.	RELIABILITY	24
11.	PRECAUTION RELATING PRODUCT HANDLING	29

1. GENERAL DESCRIPTION

1.1 Description

The specifications is model 13-057VMTBIAB1-S is a color active matrix thin film transistor (TFT) liquid crystal display (LCD) that uses amorphous silicon TFT as a switching device. This model is composed of a TFT LCD panel, a driving circuit, a back light system and a projected capacitive touch panel. This TFT LCD has a 5.7 (4:3) inch diagonally measured active display area with VGA (640 horizontal by 480 vertical pixels) resolution.

1.2 Features:

No.	Item	Specification	Unit
1	Panel Size	5.7"	Inch
2	Number of Pixels	640 (W) x RGB x 480 (H)	Pixels
3	Active Area	115.2 (W) × 86.4 (H)	mm
4	Pixel Pitch	0.1815 (W) x 0.1815 (H)	mm
5	Outline Dimension	144 (W) × 104.6 (H) × 15.28 (T)	mm
6	Number of Colors	262K	- -
7	Display Mode	TN / Normally White / Transmissive	- -
8	View Direction	12 o'clock (Gray Inversion)	
9	Display Format	RGB vertical stripe	- -
10	Surface Treatment	Clear (7H)	- -
11	Contrast Ratio	500 (Typ.)	- -
12	Luminance (cd/m ²)	1000 (Typ.)	cd/m ²
13	Interface	RGB 18bit Interface	- -
14	Backlight	White LED	- -
15	Operation Temperature	-20 ~ 70	°C
16	Storage Temperature	-30 ~ 80	°C
17	Weight	(TBD)	g

3. PIN DESCRIPTION

3.1 TFT LCD Module

Pin	Symbol	I/O	Function	Remark
1	GND	P	Ground	
2	DCLK	I	Data Clock	
3	HS	I	Horizontal synchronous signal	
4	VS	I	Vertical synchronous signal	
5	GND	P	Ground	
6	R0	I	Red data signal (LSB)	
7	R1	I	Red data signal	
8	R2	I	Red data signal	
9	R3	I	Red data signal	
10	R4	I	Red data signal	
11	R5	I	Red data signal (MSB)	
12	GND	P	Ground	
13	G0	I	Green data signal (LSB)	
14	G1	I	Green data signal	
15	G2	I	Green data signal	
16	G3	I	Green data signal	
17	G4	I	Green data signal	
18	G5	I	Green data signal (MSB)	
19	GND	P	Ground	
20	B0	I	Blue data signal (LSB)	
21	B1	I	Blue data signal	
22	B2	I	Blue data signal	
23	B3	I	Blue data signal	
24	B4	I	Blue data signal	
25	B5	I	Blue data signal (MSB)	
26	GND	P	Ground	
27	DEN	I	Data enable signal	
28	VDD	P	Power Supply for system	
29	VDD	P	Power Supply for system	
30	LRC	I	Horizontal display mode select signal H: Left / Right reverse mode L: Normal	
31	UDC	I	Vertical display mode select signal H: Normal L: Up / Down reverse mode	

32	NC	-	No connection	
33	GND	P	Ground	

Note:

1. NC Pin must be floating

3.2 Backlight Unit

Pin No.	Symbol	Function	Remark
1	LEDA	Power Supply for LED backlight	RED
2	LEDK	GND for LED backlight	BLACK

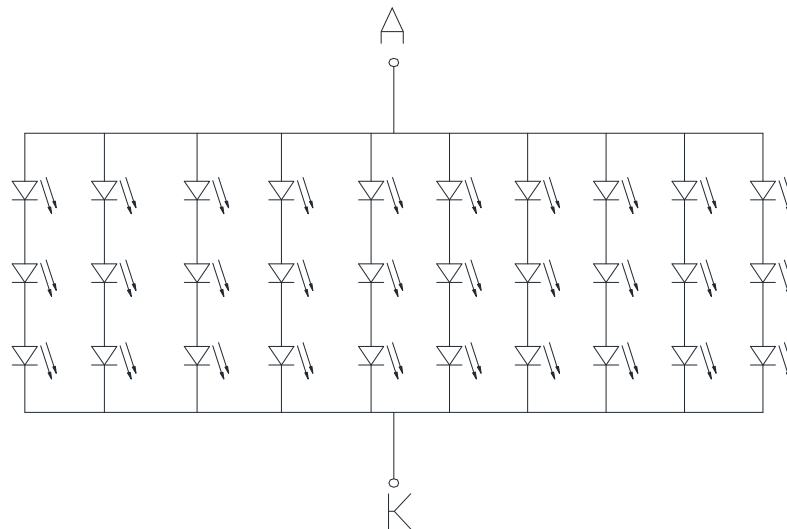

4. ABSOLUTE MAXIMUM RATINGS

4.1 Electrical Absolute Rating

4.1.1 TFT LCD Module

Item	Symbol	Values		Unit	Note
		Min	Max.		
Power supply voltage	VDD	-0.3	5.0	V	

4.1.2 Environment Absolute Rating

Item	Symbol	Values			Unit	Note
		Min	Typ	Max.		
Operating Temperature	Topa	-20		70	°C	Ambient temperature
Storage Temperature	Tstg	-30		80	°C	

5. BLOCK DIAGRAM

5.1 TFT LCD Module

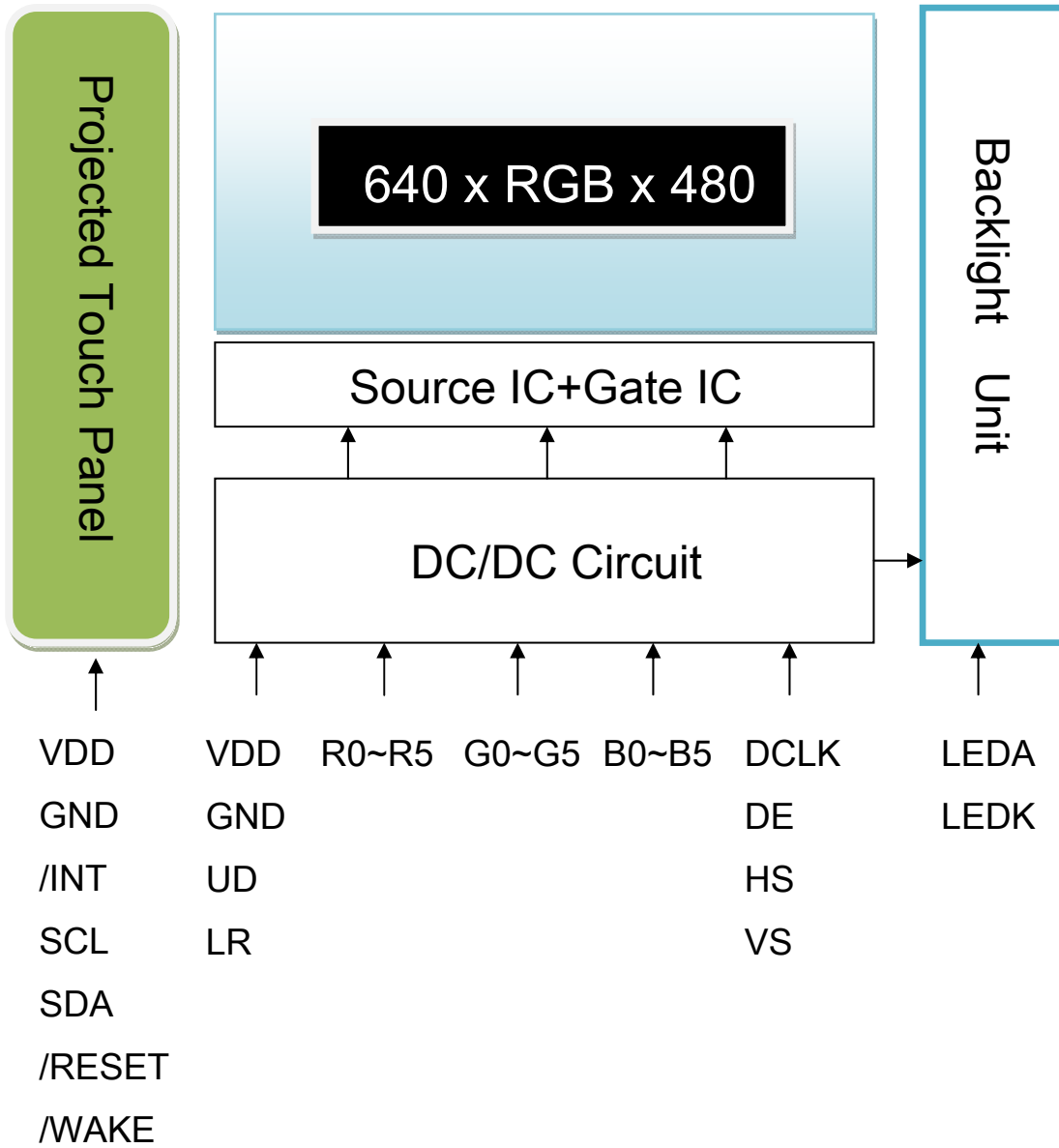

6. Relationship Between Displayed Color and Input

6.1 6 bit

	Color & Gray Scale	Data Signal																	
		R5	R4	R3	R2	R1	R0	G5	G4	G3	G2	G1	G0	B5	B4	B3	B2	B1	B0
Basic Color	Black	0	0	0	0	0	0	0	0	0	0	0	0	0	0	0	0	0	0
	Red	1	1	1	1	1	1	0	0	0	0	0	0	0	0	0	0	0	0
	Green	0	0	0	0	0	0	1	1	1	1	1	1	0	0	0	0	0	0
	Blue	0	0	0	0	0	0	0	0	0	0	0	0	1	1	1	1	1	1
	Cyan	0	0	0	0	0	0	1	1	1	1	1	1	1	1	1	1	1	1
	Magenta	1	1	1	1	1	1	0	0	0	0	0	0	1	1	1	1	1	1
	Yellow	1	1	1	1	1	1	1	1	1	1	1	1	0	0	0	0	0	0
	White	1	1	1	1	1	1	1	1	1	1	1	1	1	1	1	1	1	1
Red	Black	0	0	0	0	0	0	0	0	0	0	0	0	0	0	0	0	0	0
	Red(1)	0	0	0	0	0	1	0	0	0	0	0	0	0	0	0	0	0	0
	Red(2)	0	0	0	0	1	0	0	0	0	0	0	0	0	0	0	0	0	0
	:	:	:	:	:	:	:	:	:	:	:	:	:	:	:	:	:	:	:
	Red(31)	0	1	1	1	1	1	0	0	0	0	0	0	0	0	0	0	0	0
	:	:	:	:	:	:	:	:	:	:	:	:	:	:	:	:	:	:	:
	Red(62)	1	1	1	1	1	0	0	0	0	0	0	0	0	0	0	0	0	0
	Red(63)	1	1	1	1	1	1	0	0	0	0	0	0	0	0	0	0	0	0
Green	Black	0	0	0	0	0	0	0	0	0	0	0	0	0	0	0	0	0	0
	Green(1)	0	0	0	0	0	0	0	0	0	0	1	0	0	0	0	0	0	0
	Green(2)	0	0	0	0	0	0	0	0	0	1	0	0	0	0	0	0	0	0
	:	:	:	:	:	:	:	:	:	:	:	:	:	:	:	:	:	:	:
	Green(31)	0	0	0	0	0	0	0	1	1	1	1	0	0	0	0	0	0	0
	:	:	:	:	:	:	:	:	:	:	:	:	:	:	:	:	:	:	:
	Green(62)	0	0	0	0	0	0	1	1	1	1	1	0	0	0	0	0	0	0
	Green(63)	0	0	0	0	0	0	1	1	1	1	1	1	0	0	0	0	0	0
Blue	Black	0	0	0	0	0	0	0	0	0	0	0	0	0	0	0	0	0	0
	Blue(1)	0	0	0	0	0	0	0	0	0	0	0	0	0	0	0	0	0	1
	Blue(2)	0	0	0	0	0	0	0	0	0	0	0	0	0	0	0	0	1	0
	:	:	:	:	:	:	:	:	:	:	:	:	:	:	:	:	:	:	:
	Blue(31)	0	0	0	0	0	0	0	0	0	0	0	0	0	1	1	1	1	1
	:	:	:	:	:	:	:	:	:	:	:	:	:	:	:	:	:	:	:
	Blue(62)	0	0	0	0	0	0	0	0	0	0	0	0	1	1	1	1	1	0
	Blue(63)	0	0	0	0	0	0	0	0	0	0	0	0	1	1	1	1	1	1

0 : Low level voltage, 1 :High level voltage

Each basic color can be displayed in 64 gray scales from 6 bit data signals. With the combination of total 18 bit data signals, the 262K-color display can be achieved on the screen.

7. ELECTRICAL CHARACTERISTICS

7.1 TFT LCD Module

Item	Symbol	Value			Unit	Note	
		Min.	Typ.	Max.			
Power supply voltage	VDD	3.0	3.3	3.6	V		
Input Voltage for logic	H Level	VIH	0.7xVDD	-	VDD	V	
	L Level	VIL	0	-	0.3xVDD	V	
Digital Current	IDD	-	(150)	(220)	mA	Note1	

Note 1: frame =60Hz , Ta=25°C , Display pattern : Black pattern

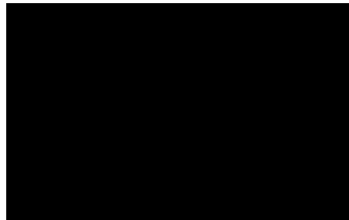

7.2 Backlight Unit

Item	Symbol	Value			Unit	Condition
		Min.	Typ.	Max.		
LED Voltage	VL	(9.0)	(9.3)	(10.5)	V	
LED Current	IF	-	200	-	mA	3S10P
Power Consumption	PBL	-	1.86	-	W	
LED Life Time (25°C)	-	(50000)	-	-	hr	(1)

Note (1): The "LED life time" is defined as the module brightness decrease to 50% original brightness that the ambient temperature is 25°C 60% RH.

7.3 INTERFACE SPECIFICATIONS

7.3.1 AC Timing characteristics

Parameter	Symbol	Min.	Typ.	Max.	Unit.	Note
CLK frequency	FCPH	22.66	25.175	27.69	MHZ	
CLK period	TCPH	36.11	39.7	44.13	ns	
CLK pulse duty	TCWH	40	50	60	%	
HS period	TH	750	800	850	TCPH	
HS pulse width	TWH	5	30	--	TCPH	
HS-first horizontal data time	THS	112	144	175	TCPH	
Display period	THA	--	640	--	TCPH	
HS setup time	THST	10	--	--	ns	
HS hold time	THHD	10	--	--	ns	
VS pulse width	TWV	1	3	5	TH	
First line data input time	TSTV	--	35	--	TH	
VS period	TV	515	525	535	TH	
VS setup time	TVST	10	--	--	ns	
VS hold time	TVHD	10	--	--	ns	

Note : When SYNC mode is used, 1st data start from 144th CLK after HS falling (when STHD[5:0]=00000)

Parameter	Symbol	Min.	Typ.	Max.	Unit.	Note
DEN Period	TDEN	--	800	--	TCPH	
DEN pulse width	TEP	--	640	--	TCPH	
DEN frame active time	TDEA	--	480	--	TDEN	
DEN frame blanking time	TDEB	--	45	--	TDEN	
DEN setup time	TESU	10	--	--	ns	

7.3.2 Clock and Data input waveforms

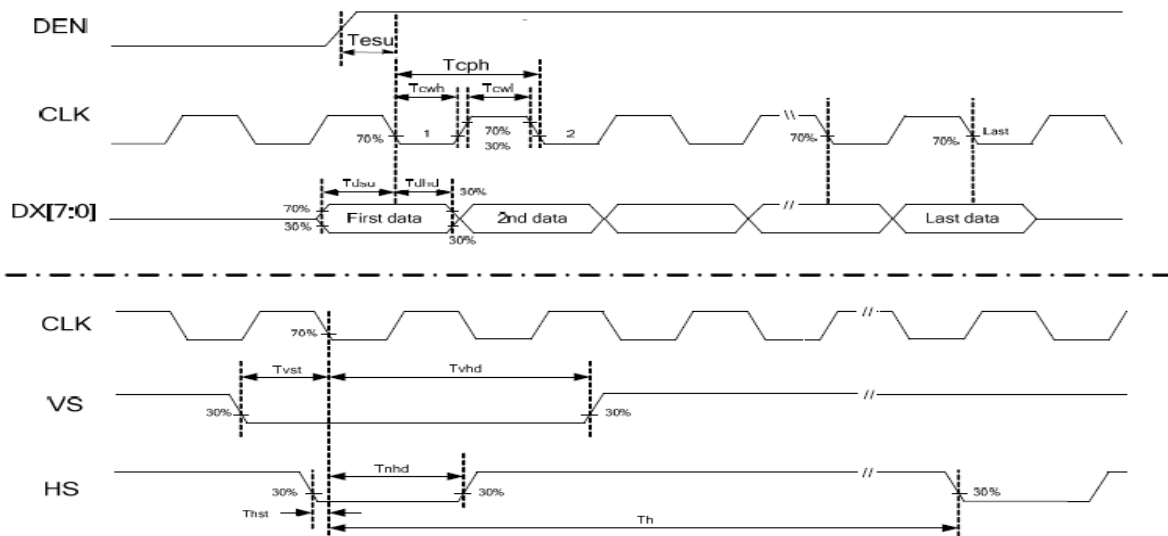

7.3.3 Parallel RGB SYNC Mode Horizontal Data Format

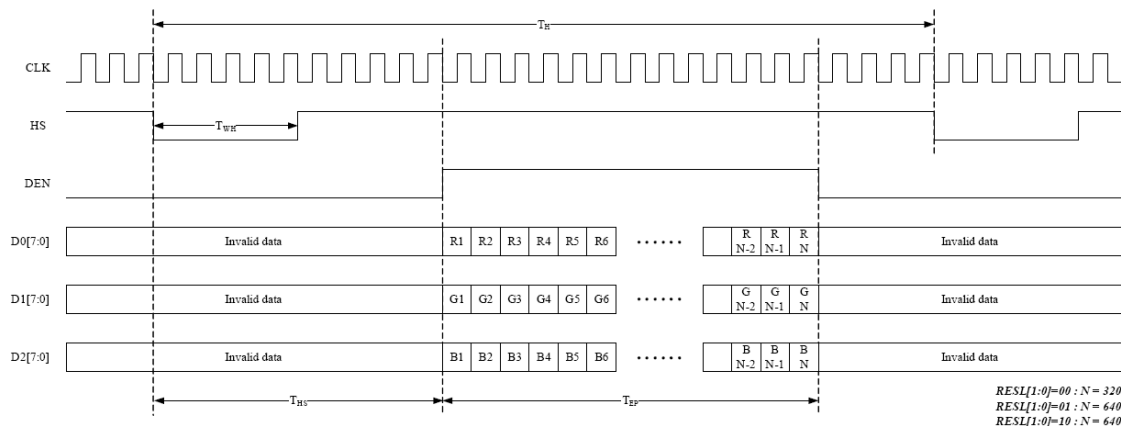

7.3.4 Parallel RGB DEN Mode Horizontal Data Format

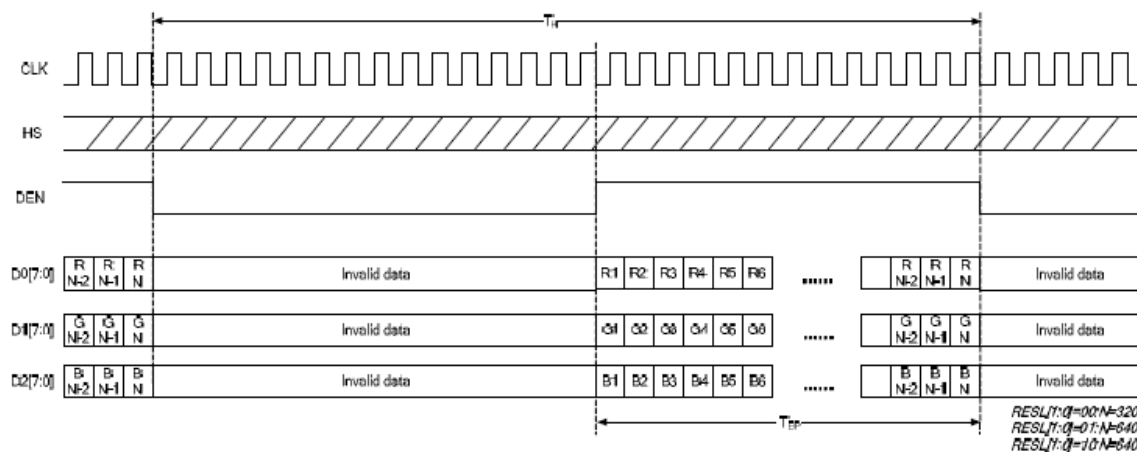

7.4 Power On / Off Sequence

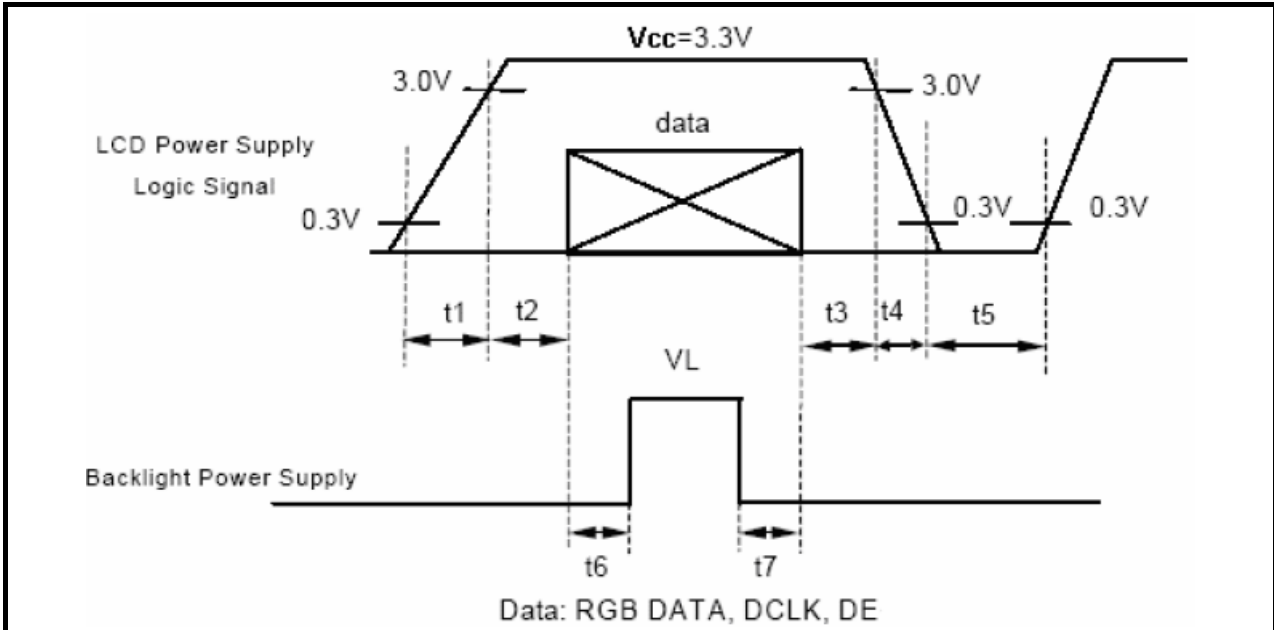

- $t_1 \leq 10\text{ms} : 1 \text{ sec} \leq t_5$
- $50\text{ms} \leq t_2 : 200\text{ms} \leq t_6$
- $0 < t_3 \leq 50\text{ms} : 200\text{ms} \leq t_7$
- $0 < t_4 \leq 10\text{ms}$

8. PROJECTED CAPACITIVE TOUCH PANEL

8.1 Main Feature

Item	Specification	Unit
Screen Size	5.7 inch	Diagonal
Type	Transparent Type Projected Capacitive	--
Input Mode	Human's Finger	--
Finger	5	--
Interface	I2C	--
Cover glass pencil-hardness	7H	--
Response time	25	ms
Driver IC	FT5216GM7	

8.2 Pin Assignments and Definitions

Item	Name	I/O	Unit
1	GND	P	Ground
2	VDD	P	Power; VDD =3.3V(typ.)
3	SCL	I	I2C clock
4	NC	-	No connection
5	SDA	I/O	I2C data
6	NC	-	No connection
7	/RST	I	External low signal reset the chip.
8	/WAKE	I	Interrupt signal for the host to change F5x06 from Hibernate to Active mode
9	/INT	O	Interrupt signal to inform the host processor that touch data is ready for read
10	GND	P	Ground

8.3 ELECTRICAL CHARACTERISTICS

Communication protocol: I2C

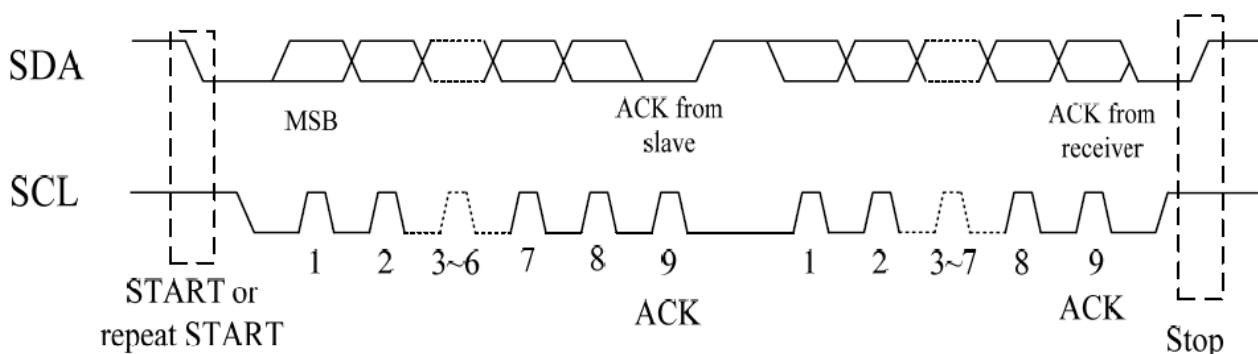

8.4 I2C Interface Protocol

8.4.1 Default I2C Address

The default I2C Address of FT5306 is 0x70 (7-bit address)

8.4.2 I2C master write, slave read

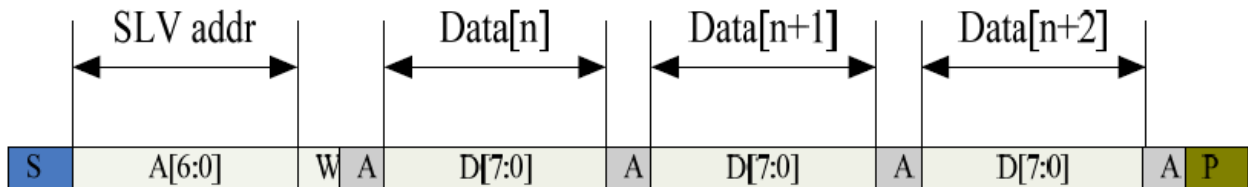

8.4.3 I2C master read, slave write

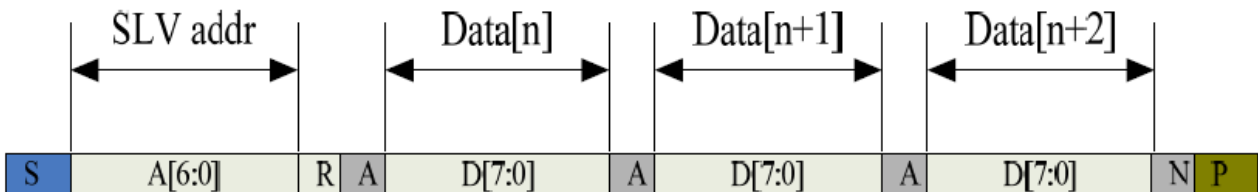

Mnemonics	Description
S	I2C Start or I2C Restart
A[6:0]	Slave address A[6:4]: 3'b011 A[3:0]: data bits are identical to those of I2CCON[7:4] register.
W	1'b0: Write
R	1'b1: Read
A(N)	ACK(NACK)
P	STOP: the indication of the end of a packet (if this bit is missing, S will indicate the end of the current packet and the beginning of the next packet)

8.5 Register Definitions

Address	Name	Bit7	Bit6	Bit5	Bit4	Bit3	Bit2	Bit1	Bit0	Host Access	
00h	DEVIDE_MODE	Device Mode[2:0]									RW
01h	GEST_ID	Gesture ID[7:0]								R	
02h	TD_STATUS					Number of touch points[3:0]				R	
03h	TOUCH1_XH	1 st Event Flag				1 st Touch X Position[11:8]				R	
04h	TOUCH1_XL	1 st Touch X Position[7:0]								R	
05h	TOUCH1_YH	1 st Touch ID[3:0]				1 st Touch Y Position[11:8]				R	
06h	TOUCH1_YL	1 st Touch Y Position[7:0]								R	
07h											
08h											
09h	TOUCH2_XH	2 nd Event Flag				2 nd Touch X Position[11:8]				R	
0Ah	TOUCH2_XL	2 nd touch X Position[7:0]								R	
0Bh	TOUCH2_YH	2 nd Touch ID[3:0]				2 nd Touch Y Position[11:8]				R	
0Ch	TOUCH2_YL	2 nd Touch Y Position[7:0]								R	
0Dh											
0Eh											
0Fh	TOUCH3_XH	3 rd Event Flag				3 rd Touch X Position[11:8]				R	
10h	TOUCH3_XL	3 rd Touch X Position[7:0]								R	
11h	TOUCH3_YH	3 rd Touch ID[3:0]				3 rd Touch Y Position[11:8]				R	
12h	TOUCH3_YL	3 rd Touch Y Position[7:0]								R	
13h											
14h											

15h	TOUCH4_XH	4 th Event Flag		4 th Touch X Position[11:8]	R
16h	TOUCH4_XL	4 th Touch X Position[7:0]			R
17h	TOUCH4_YH	4 th Touch ID[3:0]		4 th Touch Y Position[11:8]	R
18h	TOUCH4_YL	4 th Touch Y Position[7:0]			R
19h					R
1Ah					R
1Bh	TOUCH5_XH	5 th Event Flag		5 th Touch X Position[11:8]	R
1Ch	TOUCH5_XL	5 th Touch X Position[7:0]			R
1Dh	TOUCH5_YH	5 th Touch ID[3:0]		5 th Touch Y Position[11:8]	R
1Eh	TOUCH5_YL	5 th Touch Y Position[7:0]			R
1Fh					R
20h					R
21h	TOUCH6_XH	6 th Event Flag		6 th Touch X Position[11:8]	
22h	TOUCH6_XL	6 th Touch X Position[7:0]			
23h	TOUCH6_YH	6 th Touch ID[3:0]		6 th Touch Y Position[11:8]	
24h	TOUCH6_YL	6 th Touch Y Position[7:0]			
25h					
26h					
27h	TOUCH7_XH	7 th Event Flag		7 th Touch X Position[11:8]	
28h	TOUCH7_XL	7 th Touch X Position[7:0]			
29h	TOUCH7_YH	7 th Touch ID[3:0]		7 th Touch Y Position[11:8]	
2Ah	TOUCH7_YL	7 th Touch Y Position[7:0]			
2Bh					
2Ch					
2Dh	TOUCH8_XH	8 th Event Flag		8 th Touch X Position[11:8]	
2Eh	TOUCH8_XL	8 th Touch X Position[7:0]			
2Fh	TOUCH8_YH	8 th Touch ID[3:0]		8 th Touch Y Position[11:8]	
30h	TOUCH8_YL	8 th Touch Y Position[7:0]			
31h					
32h					

33h	TOUCH9_XH	9 th Event Flag		9 th Touch X Position[11:8]	
34h	TOUCH9_XL	9 th Touch X Position[7:0]			
35h	TOUCH9_YH	9 th Touch ID[3:0]		9 th Touch Y Position[11:8]	
36h	TOUCH9_YL	9 th Touch Y Position[7:0]			
37h					
38h					
39h	TOUCH10_XH	10 th Event Flag		10 th Touch X Position[11:8]	
3Ah	TOUCH10_XL	10 th Touch X Position[7:0]			
3Bh	TOUCH10_YH	10 th Touch ID[3:0]		10 th Touch Y Position[11:8]	
3Ch	TOUCH10_YL	10 th Touch Y Position[7:0]			
3Dh					
3Eh					
3Fh	Reserved				
...	...				
7Fh	Reserved				
80h	ID_G_THGROUP	valid touching detect threshold.			R/W
81h	ID_G_THPEAK	valid touching peak detect threshold.			R/W
82h	ID_G_THCAL	the threshold when calculating the focus of touching.			R/W
83h	ID_G_THWATER	the threshold when there is surface water.			R/W
84h	ID_G_THTEMP	the threshold of temperature compensation.			R/W
85h					R/W
86h	ID_G_CTRL			Power control mode[1:0]	R/W
87h	ID_G_TIME_ENTER_MONITOR	The timer of entering monitor status			R/W
88h	ID_G_PERIODACTIVE			Period Active[3:0]	R/W
89h	ID_G_PERIODMONITOR	The timer of entering idle while in monitor status			R/W
8Ah					R/W
8Bh					R/W
8Ch					R/W
8Dh					R/W
8Eh					R/W
8Fh					R/W
90h					R/W

91h			R/W
92h			R/W
93h			R/W
94h			R/W
95h			R/W
96h			R/W
97h			R/W
98h			R/W
99h			R/W
9Ah			R/W
9Bh			R/W
9Ch			R/W
9Dh			R/W
9Eh			R/W
9Fh			R/W
A0h	ID_G_AUTO_CLB_MODE	auto calibration mode	R/W
A1h	ID_G_LIB_VERSION_H	Firmware Library Version H byte	R
A2h	ID_G_LIB_VERSION_L	Firmware Library Version L byte	R
A3h	ID_G_CIPHER	Chip vendor ID	R
A4h	ID_G_MODE	the interrupt status to host	R
A5h	ID_G_PMODE	Power Consume Mode	
A6h	ID_G_FIRMID	Firmware ID	R
A7h	ID_G_STATE	Running State	
A8h	ID_G_FT5201ID	CTPM Vendor ID	R
A9h	ID_G_ERR	Error Code	R
AAh	ID_G_CLB	Configure TP module during calibration in Test Mode	R/W
ABh			R/W
ACh			R/W
ADh			R/W
AEh	ID_G_B_AREA_TH	The threshold of big area	R/W
AFh			R/W
...	...		
FDh	Reserved		
FEh	LOG_MSG_CNT	The log MSG count	R
FFh	LOG_CUR_CHA	Current character of log message, will point to the next character when one character is read.	R

9. OPTICAL CHARACTERISTICS

Item	Symbol	Condition	Min.	Typ.	Max.	Unit
Brightness	--	Note1, Note 3, ($\theta = 0^\circ$; Normal Viewing Angle)	800	1000	--	cd/m ²
Uniformity	B-uni		70	75	-	%
Contrast Ratio	CR		400	500	--	--
Response Time	Tr		--	15	20	ms
	Tf	--	25	35	ms	
Color Chromaticity	White	Wx	0.260	0.310	0.360	--
		Wy	0.280	0.330	0.380	--
View angle	Horizontal	$\theta x+$	55	65	--	
		$\theta x-$	55	65	--	
	Vertical	$\theta Y+$	55	65	--	
		$\theta Y-$	40	50	--	

Note : The following optical specifications shall be measured in a darkroom or equivalent state(ambient luminance ≤ 1 lux, and at room temperature). The operation temperature is $25^\circ\text{C} \pm 2^\circ\text{C}$. The measurement method is shown in Note1.

Note1: The method of optical measurement:

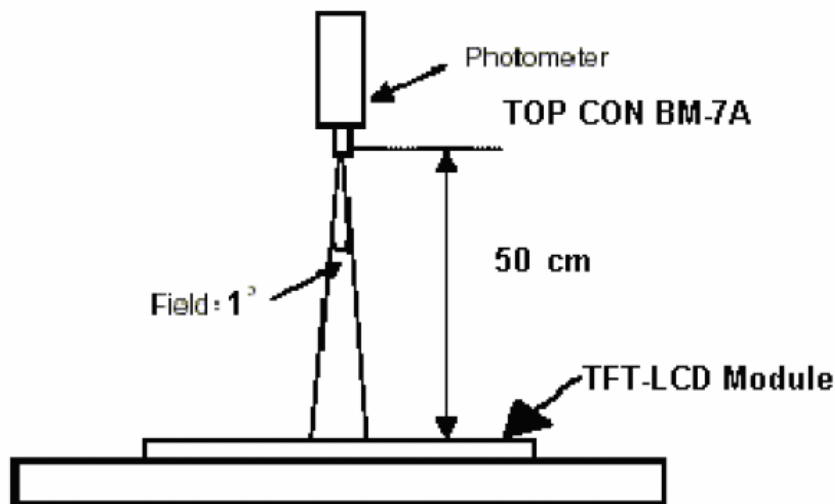

Note2: Measured at the center area of the panel and at the viewing angle of the $\theta x = \theta y = 0^\circ$

Note3: Definition of Contrast Ratio (CR):

CR = Luminance with all pixels in white state \div Luminance with all pixels in Black state

Note 4: Definition of Viewing Angle:

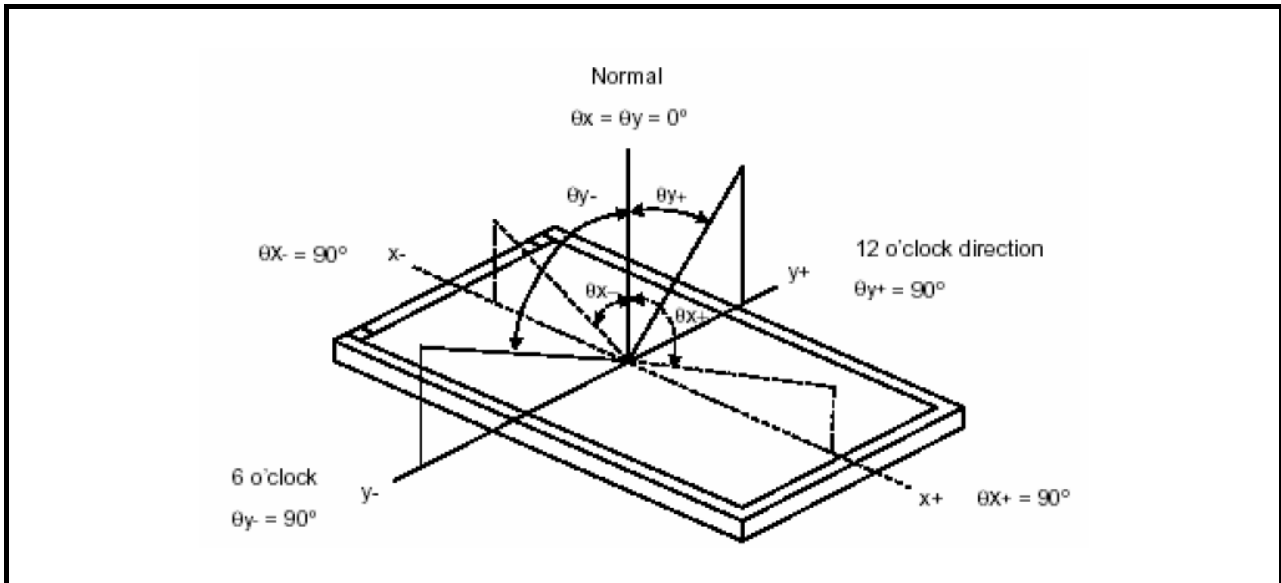

Note 5: Definition of Brightness Uniformity (B-uni):

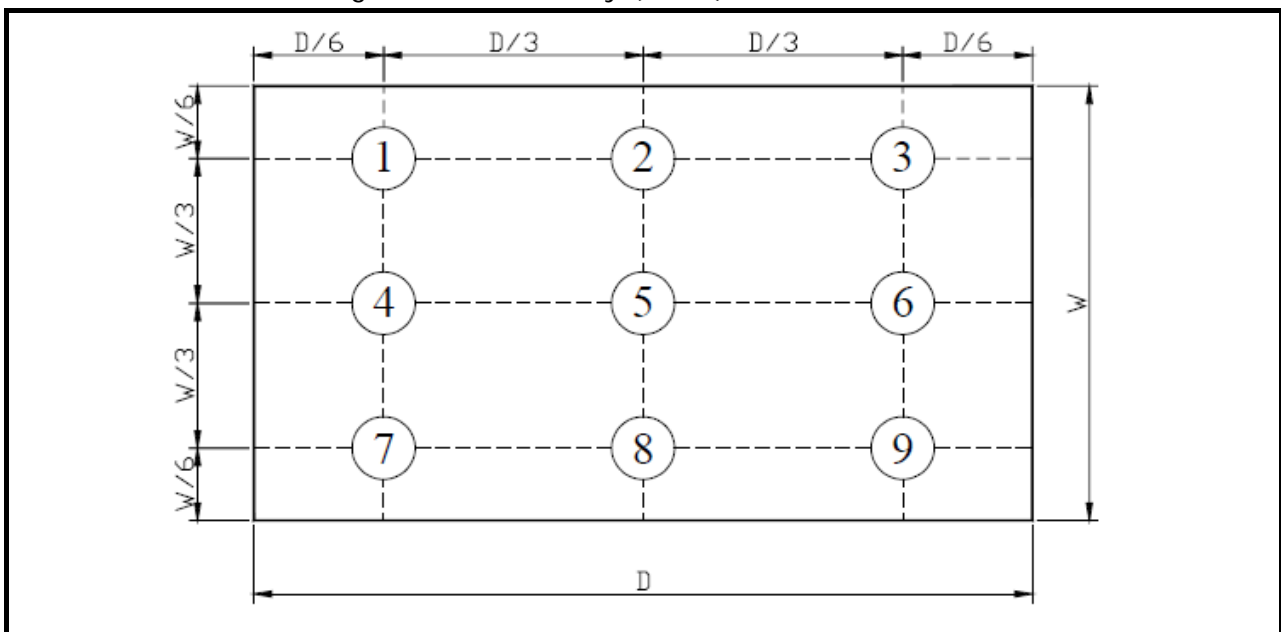

B-uni = (Minimum luminance of 9 points ÷ Maximum luminance of 9 points) X 100%

Note 6: Definition of Response Time:

The Response Time is set initially by defining the “Rising Time (Tr)” and the “Falling Time (Tf)” respectively. Tr and Tf are defined as following figure

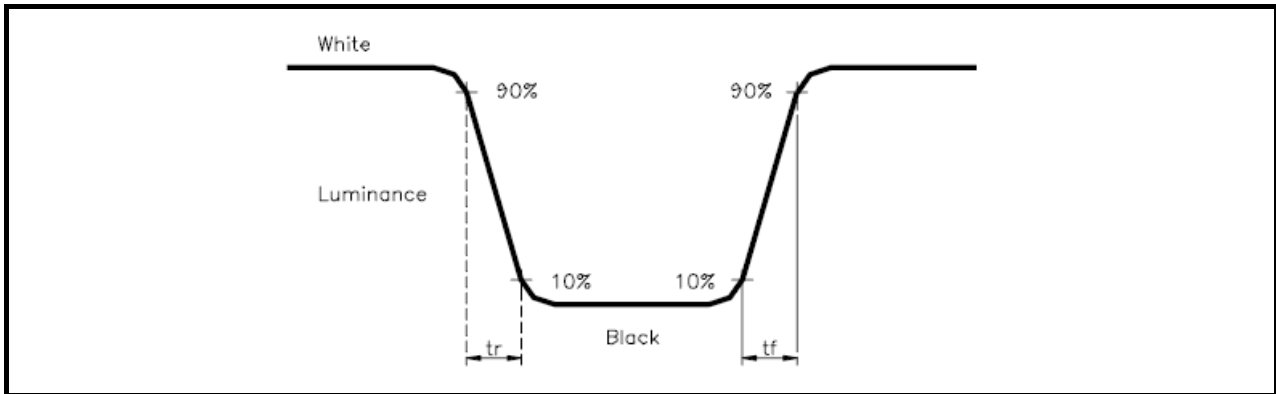

Note 7: Definition of Chromaticity:

The color coordinates (Wx,Wy), (Rx,Ry), (Gx,Gy), and (Bx,By) are obtained with all pixels in the viewing field at white, red, green, and blue states, respectively.

10. RELIABILITY

10.1 Test Condition

10.1.1 Temperature and Humidity(Ambient Temperature)

Temperature : 25 ± 5°C

Humidity : 65 ± 5%

10.1.2 Operation

Unless specified otherwise, test will be conducted under function state.

10.1.3 Container

Unless specified otherwise, vibration test will be conducted to the product itself without putting it in a container.

10.1.4 Test Frequency

In case of related to deterioration such as shock test. It will be conducted only once.

10.2 TESTS

No.	ITEM	CONDITION CRITERION
1	High Temperature Storage	80°C, 120 hrs
2	Low Temperature Storage	-30°C, 120 hrs
3	High Temperature Operating	70°C, 120 hrs
4	Low Temperature Operating	-20°C, 120 hrs
5	High Temperature/Humidity Non-Operating	60°C, 90%RH, 120 hrs
6	Temperature Shock Non-Operating	-30°C ←→ 80°C (0.5hr each), 25 cycles
7	Vibration Test Non-Operating	Frequency:0 ~ 55 Hz Amplitude:1.5 mm Sweep Time:11min Test Period:6 Cycles for each Direction of X,Y,Z
8	Electro-static Discharge	±2KV, Human Body Mode, 100pF/1500Ω

Note1: The test sample have recovery time for 24 hours at room temperature before the function check. In the standard conditions, there is no any touch panel function NG issue occurred.

10.3 JUDGMENT STANDARD

The judgment of the above test should be made as follow:

Pass: Normal display image with no obvious non-uniformity and no line defect. Partial transformation of the module parts should be ignored.

Fail: No display image, obvious non-uniformity, or line defects.

10.4 INCOMING INSPECTION STANDARDS

No.	Parameter	Criteria														
1	Operating	Display function: No Display malfunction (Major)														
		Contrast ratio (Black, White): Does not meet specified range in the spec. (Major) (Note:3)														
		Line Defect: No obvious Vertical and Horizontal line defect in bright, dark and colored. (Major) (Note:1)														
		Point Defect : Active area ≤ 5 dots (Minor) (Note:1)														
		<table border="1"> <thead> <tr> <th rowspan="2">Item</th> <th>Acceptable number</th> <th rowspan="2">Total</th> </tr> <tr> <th>Active Area</th> </tr> </thead> <tbody> <tr> <td>Bright</td> <td>2</td> <td rowspan="2">5</td> </tr> <tr> <td>Dark</td> <td>4</td> </tr> </tbody> </table>	Item	Acceptable number	Total	Active Area	Bright	2	5	Dark	4					
Item	Acceptable number	Total														
	Active Area															
Bright	2	5														
Dark	4															
2	External Inspection (non-operating)	Non-uniformity: Visible through 5%ND filter. (Minor)														
		Foreign material in Black or White spots shape ($W > 1/4L$)														
		<table border="1"> <thead> <tr> <th>Zone Dimension</th> <th>Acceptable number</th> <th rowspan="3">Class Of Defects</th> <th rowspan="3">AQL Level</th> </tr> </thead> <tbody> <tr> <td>$D > 0.5$</td> <td>0</td> </tr> <tr> <td>$0.3 < D \leq 0.5$</td> <td>5</td> </tr> <tr> <td>$D \leq 0.3$</td> <td>*</td> <td>Minor</td> <td>1.5</td> </tr> </tbody> </table> <p>$D = (\text{Long} + \text{Short}) / 2$ * : Disregard</p>	Zone Dimension	Acceptable number	Class Of Defects	AQL Level	$D > 0.5$	0	$0.3 < D \leq 0.5$	5	$D \leq 0.3$	*	Minor	1.5		
		Zone Dimension	Acceptable number	Class Of Defects			AQL Level									
		$D > 0.5$	0													
$0.3 < D \leq 0.5$	5															
$D \leq 0.3$	*	Minor	1.5													
Foreign Material in Line or spiral shape ($W \leq 1/4L$) (Note: 4)																
<table border="1"> <thead> <tr> <th>L (mm)</th> <th>Zone W(mm)</th> <th>Acceptable number</th> <th rowspan="3">Class Of Defects</th> <th rowspan="3">AQL Level</th> </tr> </thead> <tbody> <tr> <td>$L > 5$</td> <td>$W > 0.1$</td> <td>0</td> </tr> <tr> <td>$0.5 < L \leq 5$</td> <td>$0.03 < W \leq 0.1$</td> <td>5</td> </tr> <tr> <td>$L \leq 0.5$</td> <td>$W \leq 0.03$</td> <td>*</td> <td>Minor</td> <td>1.5</td> </tr> </tbody> </table> <p>L : Length W : Width * : Disregard</p>	L (mm)	Zone W(mm)	Acceptable number	Class Of Defects	AQL Level	$L > 5$	$W > 0.1$	0	$0.5 < L \leq 5$	$0.03 < W \leq 0.1$	5	$L \leq 0.5$	$W \leq 0.03$	*	Minor	1.5
L (mm)	Zone W(mm)	Acceptable number	Class Of Defects			AQL Level										
$L > 5$	$W > 0.1$	0														
$0.5 < L \leq 5$	$0.03 < W \leq 0.1$	5														
$L \leq 0.5$	$W \leq 0.03$	*	Minor	1.5												
2	External Inspection (non-operating)	Dimension: Outline (Major)														
		Bezel appearance: uneven (Minor)														
		Scratch on the polarize: (Note:2)														
		<table border="1"> <thead> <tr> <th>L (mm)</th> <th>Zone W(mm)</th> <th>Acceptable number</th> <th rowspan="2">Class Of Defects</th> <th rowspan="2">AQL Level</th> </tr> </thead> <tbody> <tr> <td>--</td> <td>$W > 0.1$</td> <td>0</td> </tr> <tr> <td>$L \leq 3$</td> <td>$W \leq 0.1$</td> <td>3</td> <td>Minor</td> <td>1.5</td> </tr> </tbody> </table> <p>L : Length W : Width * : Disregard</p>	L (mm)	Zone W(mm)	Acceptable number	Class Of Defects	AQL Level	--	$W > 0.1$	0	$L \leq 3$	$W \leq 0.1$	3	Minor	1.5	
		L (mm)	Zone W(mm)	Acceptable number	Class Of Defects			AQL Level								
--	$W > 0.1$	0														
$L \leq 3$	$W \leq 0.1$	3	Minor	1.5												
Dent or bubble on the polarize (Note:2)																
<table border="1"> <thead> <tr> <th>Zone Dimension</th> <th>Acceptable number</th> <th rowspan="2">Class Of Defects</th> <th rowspan="2">AQL Level</th> </tr> </thead> <tbody> <tr> <td>$D \leq 0.3$</td> <td>*</td> </tr> <tr> <td>$D \leq 0.5$</td> <td>3</td> <td>Minor</td> <td>1.5</td> </tr> </tbody> </table> <p>$D = (\text{Long} + \text{Short}) / 2$ * : Disregard</p>	Zone Dimension	Acceptable number	Class Of Defects	AQL Level	$D \leq 0.3$	*	$D \leq 0.5$	3	Minor	1.5						
Zone Dimension	Acceptable number	Class Of Defects			AQL Level											
$D \leq 0.3$	*															
$D \leq 0.5$	3	Minor	1.5													

Class of defects			Definition
	Major	AQL 0.65%	It is a defect that is likely to result in failure or to reduce materially the usability of the product for the intended function.
Minor	AQL 1.5%	It is a defect that will not result in functioning problem with deviation classified.	

Note1:

(a) Bright point defect is defined as point defect of R,G,B with area $>1/2$ pixel respectively

(b) Dark point defect is defined as visible in full white pattern.

(c) Definition of distribution of point defect is as follows:

- minimum separation between dark point defects should be larger than 5mm.
- minimum separation between bright point defects should be larger than 5mm.

(d) Definition of joined bright point defect and joined dark point defect are as follows:

- Two or more joined bright point defects must be nil.
- Three joined dark point defects must be nil.
- Coupling of one dark and one bright point in junction is counted as one dark and bright spot with 1 pair maximum.
- Two Joined dark point is counted as two dark points with 2 pair maximum.

Note2: The external inspection should be conducted at the distance 30 ± 5 cm between the eyes of inspector and the panel.

Note3: Luminance measurement for contrast ratio is at the distance 50 ± 5 cm between the detective head and the panel with ambient luminance less than 1 lux. Contrast ratio is obtained at optimum view angle.

Note4: W-Width in mm , L-length of Max.(L1,L2) in mm.

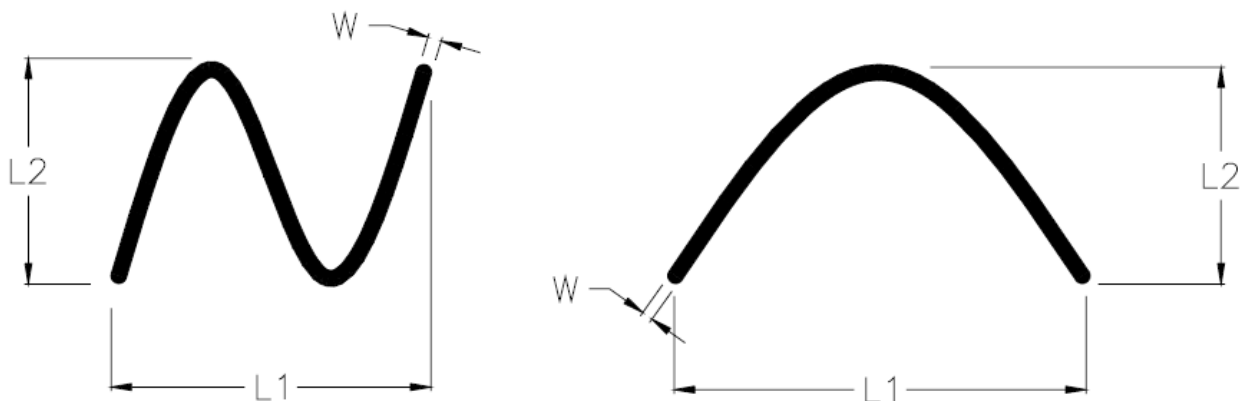

10.5 Sampling Condition

Unless otherwise agree in written, the sampling inspection shall be applied to the incoming inspection of customer.

Lot size: Quantity of shipment lot per model.

Sampling type: normal inspection, single sampling

Sampling table: MIL-STD-105E

Inspection level: Level II

10.6 Inspection conditions

The LCD shall be inspected under 40W white fluorescent light.

$\theta \leq 45^\circ$ inspection under non-operating condition.

$\theta \leq 5^\circ$ inspection under operating condition

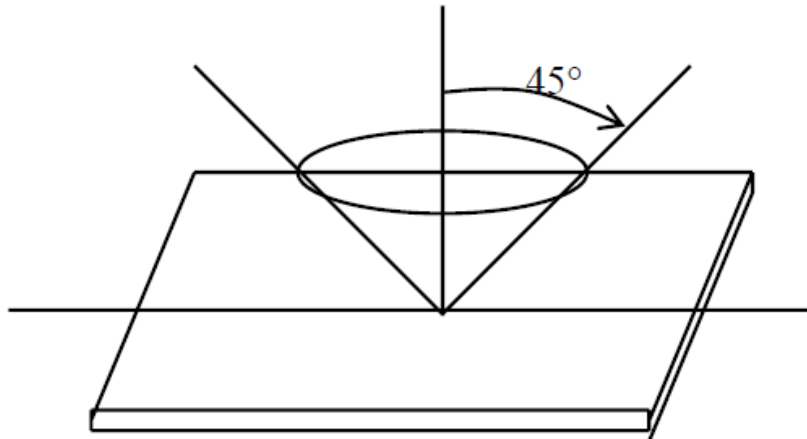

11. PRECAUTION RELATING PRODUCT HANDLING

11.1 SAFETY

11.1.1 If the LCD panel breaks , be careful not to get the liquid crystal to touch your skin.

11.1.2 If the liquid crystal touches your skin or clothes , please wash it off immediately by using soap and water.

11.2 HANDLING

11.2.1 Avoid any strong mechanical shock which can break the glass.

11.2.2 Avoid static electricity which can damage the CMOS LSI—When working with the module, be sure to ground your body and any electrical equipment you may be using.

11.2.3 Do not remove the panel or frame from the module.

11.2.4 The polarizing plate of the display is very fragile. So , please handle it very carefully, Do not touch, push or rub the exposed polarizing with anything harder than an HB pencil lead (glass , tweezers , etc.)

11.2.5 Do not wipe the polarizing plate with a dry cloth, as it may easily scratch the surface of plate.

11.2.6 Do not touch the display area with bare hands , this will stain the display area.

11.2.7 Do not use ketonics solvent & aromatic solvent. Use with a soft cloth soaked with a cleaning naphtha solvent.

11.2.8 To control temperature and time of soldering is $280 \pm 10^{\circ}\text{C}$ and 3-5 sec.

11.2.9 To avoid liquid (include organic solvent) stained on LCM.

11.3 STORAGE

11.3.1 Store the panel or module in a dark place where the temperature is $25^{\circ}\text{C} \pm 5^{\circ}\text{C}$ and the humidity is below 65% RH.

11.3.2 Do not place the module near organics solvents or corrosive gases.

11.3.3 Do not crush, shake, or jolt the module.